

## Chapter 1

### 1.1



The bond formed between two atoms, by sharing a pair of electrons, is called a “covalent bond”.

A covalent bond is represented as a line joining the two atoms.

As discussed in sections 1.4 and 1.5, each carbon atom has four valence electrons, therefore is able to form four covalent bonds; whereas, each atom of hydrogen with only one valence electron can only form one covalent bond.

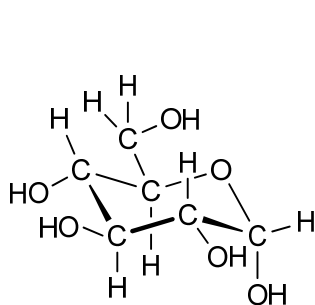

$\alpha$ -D-glucose

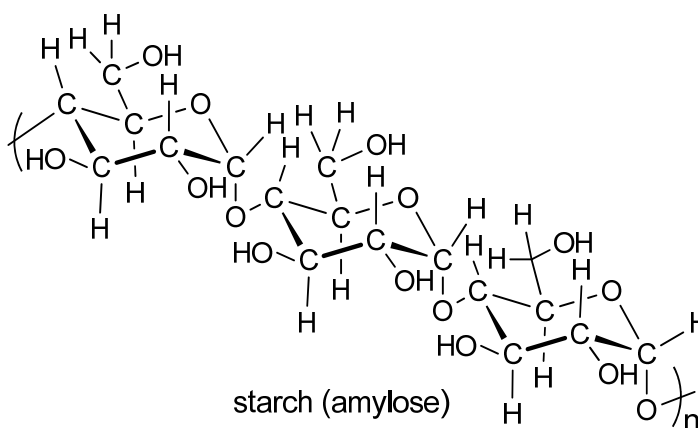

starch (amylose)

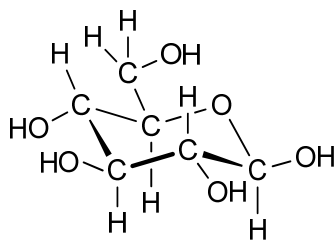

$\beta$ -D-glucose

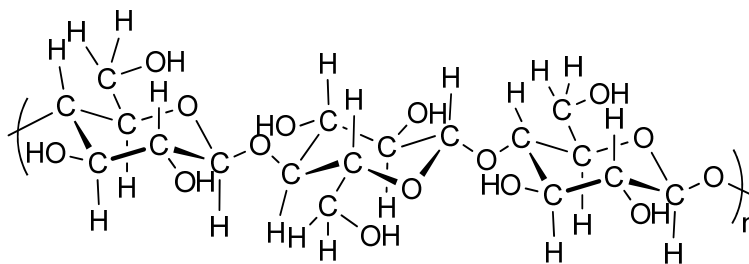

cellulose

### 1.2

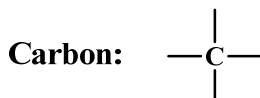

The “octet rule” is a rule that states that 2<sup>nd</sup> row atoms tend to combine in such a way that each have eight electrons in their valence shells, thus giving them the same electronic configuration as the nearest noble gas.

Carbon (C) and oxygen (O) belong to the second row. They tend to give the same configuration as Ne (8 valence electrons). Whereas, each hydrogen atom (first row element) obeys the equivalent of the “octet rule” and tends to give the electronic configuration of helium ( ${}^2\text{He}$ ; 2 valence electrons).

1.3

Look ahead to sections 1.4 and 1.5 in answering this problem.

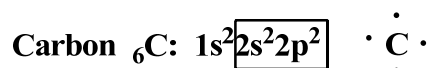
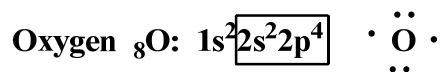

- Each oxygen atom has six valence electrons. Two are used in forming two covalent bonds, leaving two lone pairs (non-bonding electrons) that are not shown in Fig.1.1.
- Every carbon atom has four valence electrons available that can form four valence bonds (as shown in problem 1.1).
- Each hydrogen atom has only one electron available for bonding, which is used in forming one single covalent bond.

1.4

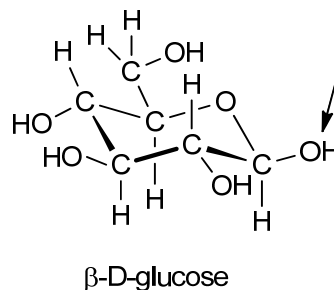
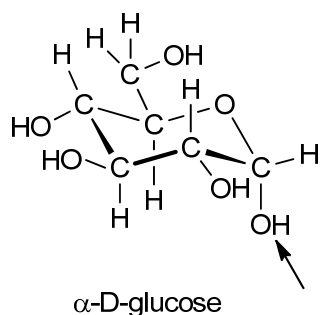

$\alpha$  and  $\beta$ -D-glucose differ only in one  $-\text{OH}$  group, which is pointing downward in  $\alpha$ -D-glucose and upward in  $\beta$ -D-glucose

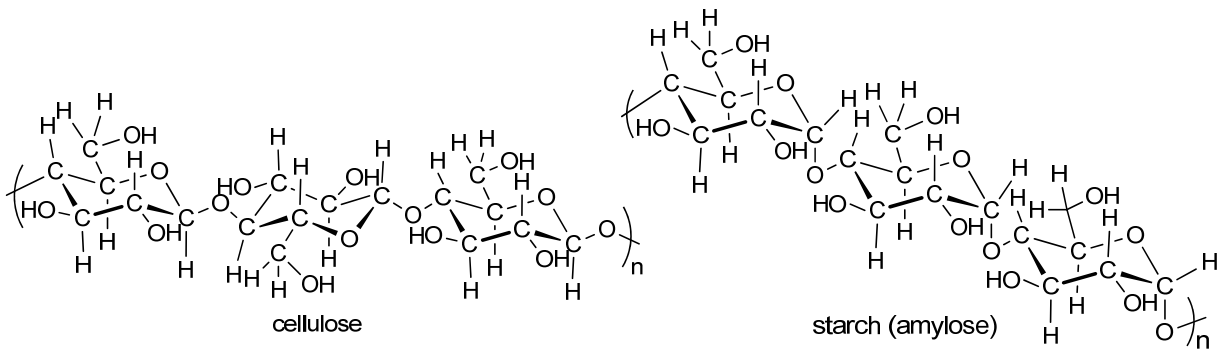

The difference between amylose and cellulose resembles the difference between  $\alpha$  and  $\beta$ -D-glucose.

1.5



The two glucose structures differ only in shape and the difference between  $\alpha$ - and  $\beta$ -glucose resembles that between amylose and cellulose. This difference is found in only one atom of oxygen, which is pointing downward in  $\alpha$ -D- glucose and amylose; and upward in  $\beta$ -D-glucose and cellulose.

1.6

According to the chemical structures reported in "answer P 1.1 ", the two forms of glucose have six carbon atom, six Oxygen atom and twelve hydrogen atoms, which correspond to the same formula  $C_6H_{12}O_6$  or  $(C_6(H_2O)_6)$ .

The molecular weight is:  $MW(\alpha) = MW(\beta) = 6 \times 12 + 12 \times 1 + 6 \times 16 = 180 \text{g} \cdot \text{mol}^{-1}$

1.7

Each unit of the two polymers (amylose and cellulose) as shown in Fig 1.1 is a combination of 3 molecules of glucose less 3 molecules of water.

$$MW(\text{polymer}) \approx [3 \times 180 - 3 \times 18] \cdot n \approx 486 n$$

1.8

Stereoisomers have the same formula and only differ in their shapes, therefore they must have the same molecular weight. i.e.:  $MW(\alpha\text{-glucose}) = MW(\beta\text{-glucose})$ .

$\alpha$ - and  $\beta$ -glucose are *stereoisomers*.

1.9

Stereoisomers only differ in their three-dimensional structures; therefore, they must have the identical connections between the atoms.

1.10

The stereoisomers we have seen so far are molecules with different three-dimensional shapes. However, as we shall see in section 1.6, there are stereoisomers with identical shapes.

1.11

Each carbon atom can form four covalent bonds, whereas, each Hydrogen atom can only form one single bond. As a result in all structures, corresponding to the formula  $C_8H_{18}$  every hydrogen atom is connected to a carbon and carbon atoms should be connected to each other and to hydrogen atoms.

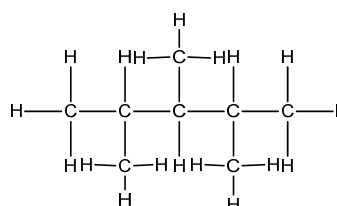
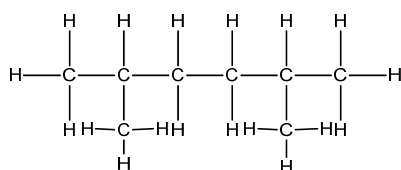
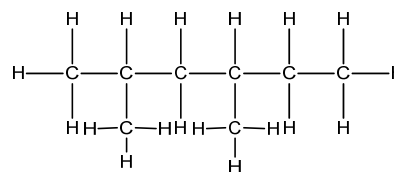
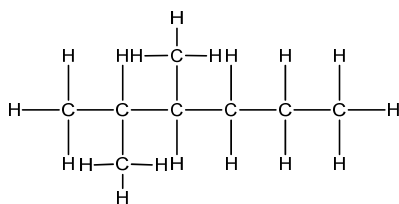
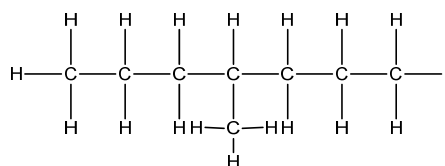
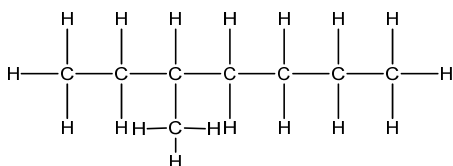
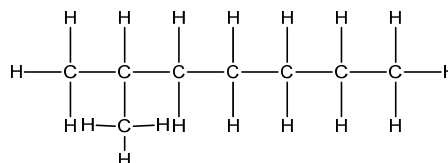
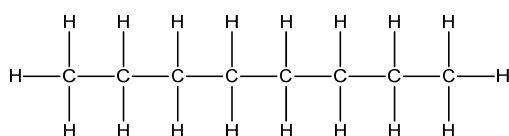

Here are eight – can you imagine others?

Are (A) and (B) stereoisomers? No. Because they have different atom-to-atom connections.  
 Are (C) and (D) stereoisomers? No. Because they have different atom-to-atom connections.

A pair of structures that are different but are not stereoisomers are named “*structural isomers*”  
 e.g. (A, B), (C, D), etc.

1.12

**Isolated carbon atom**

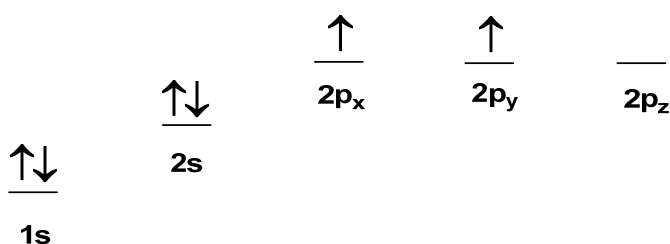

**Isolated oxygen atom**

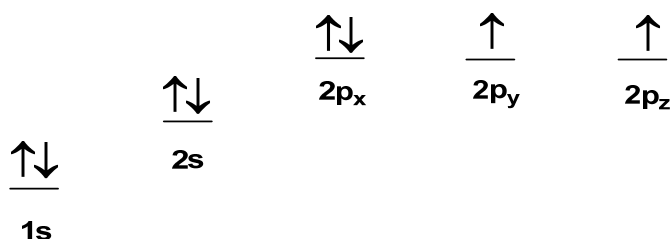

**Isolated hydrogen atom**

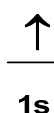

According to the electron configuration, the arrangements of electrons in the valence shell orbitals of the isolated atoms allow oxygen and carbon to be divalent because there are two unpaired electrons and hydrogen to be monovalent with one unshared electron.

This state of the carbon atom does not explain the tetravalent nature of carbon which is observed experimentally.

1.13

- a) In a tetracoordinate carbon, one s orbital (2s) and three p orbitals (2p<sub>x</sub>, 2p<sub>y</sub>, 2p<sub>z</sub>) are mixed to make four new identical orbitals that are suitable for bonding. These new identical orbitals are called: “hybridized orbitals sp<sup>3</sup>”.
- $1(2s) + 3(2p) = 4(sp^3) \Rightarrow sp^3 = 1/4 (2s) + 3/4 (2p)$ ; each hybridized orbital sp<sup>3</sup> contains 25% s and 75% p.

- b) Because the three p orbitals that make up part of each of the four hybridized orbitals,  $sp^3$ , are arrayed along the x,y,z directions, the hybridized orbitals must exist in all three of these dimensions.
- c) Each of the four bonds surrounding the central carbon atom contains two electrons. The bonds, with their negative charges, repel each other. Arraying the four bonds to the corners of a tetrahedron maximizes the distance between the bonds, therefore minimizing the electron repulsions.

1.14

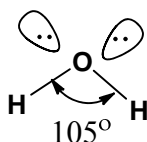

Oxygen atom has six valence electrons in orbitals 2s and 2p. One “s” orbital (2s) and 3 “p” orbitals are mixed together to give four orbitals, each  $sp^3$ . Of the four hybridized orbitals, two form covalent bonds with the s orbitals of hydrogen atoms. The remaining two hybridized orbitals are occupied by two lone pair electrons. According to the VSEPR theory, lone pair – lone pair repulsion > lone pair – covalent bond > covalent bond – covalent bond repulsion. As a result,  $H_2O$  is a distorted tetrahedron with the angle between the two O-H covalent bonds ( $105^\circ$ ) smaller than that of the regular tetrahedron ( $109.47^\circ$ ).

1.15

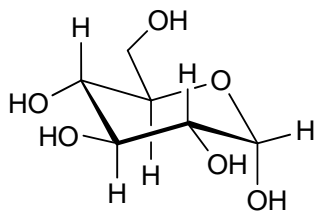

$\alpha$ -D-glucose

If the six-membered ring were planar, one would expect the bond angles to be  $120^\circ$  around all six atoms in the ring, as in a hexagon. Since, the six atoms in the ring have an approximate tetrahedral geometry, the bond angles should be close to those of a tetrahedron, therefore preventing the ring from being planar. Chapter 3 goes further into this.

1.16

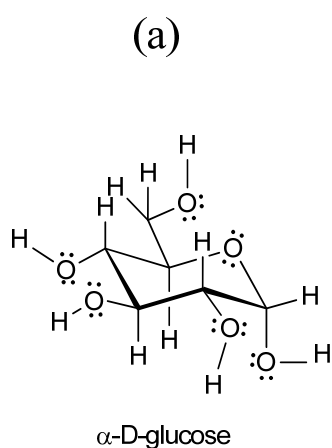

(b)

- Carbon ( ${}_6\text{C}$ ): 6 protons (positive charges)

**Accounting:** 1 electron from each bond = 4  
2 electrons in 1s orbital = 2  
Total = 6

No formal charge

- Oxygen ( ${}_8\text{O}$ ): 8 protons (positive charges)

**Accounting:** 1 electron from each bond = 2  
2 electrons in 1s orbital = 2  
4 non-bonding electrons = 4  
Total = 8

No formal charge

1.17

The formal charge of an atom, if any, in a bonded state is the difference between the number of protons in the nucleus of that atom and the number of surrounding electrons.

1.18

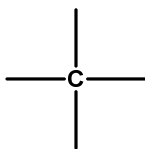

In a tetracoordinate carbon, the two inner 1s electrons are always uninvolved in bonding and therefore countering the positive charge of two of the nuclear protons. Half of the eight bonding electrons surrounding the carbon atom count toward neutralizing the remaining four proton charges in the nucleus.

1.19

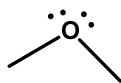

In a divalent oxygen atom, the two inner electrons in the 1s orbital are uninvolved on bonding therefore countering the positive charge of two of the eight nuclear protons. Half of the four electrons involved in the two bonds counters the positive charge of two of the six remaining

protons and the four non bonding (lone pair) electrons count toward neutralizing the remaining four nuclear proton charges.

1.20

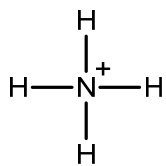

- Nitrogen ( ${}_{7}\text{N}$ ): 7 protons (positive charges)

**Accounting:** 1 electron from each bond = 4  
 2 electrons in 1s orbital = 2  
 Total = 6  
 The formal charge is +1

The two electrons in the 1s orbital are uninvolved in bonding therefore countering the positive charge of two of the seven nuclear protons. Half of the eight bonding electrons count toward neutralizing four positive charges. The remaining positive charge (one) is responsible for the formal charge.

1.21

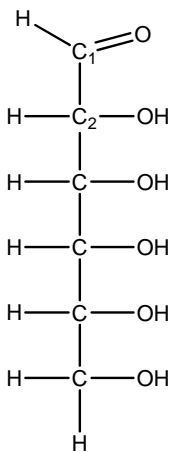

- No formal charge  
 - Obeys the octet rule

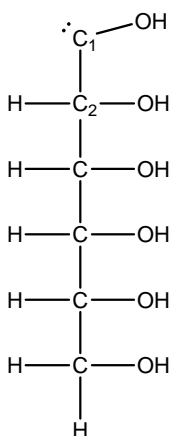

- No formal charge  
 - C1 violates the octet rule

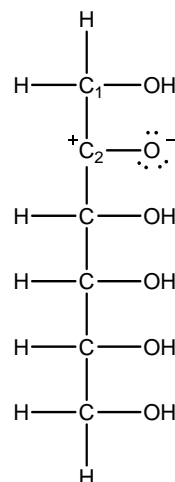

- Formal charge: +1 (C2)  
 and -1 (O)  
 - C2 violates the octet rule

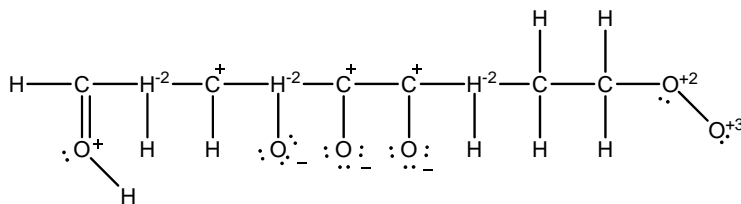

- Presence of many formal charges:  
 - Several violations of the octet rule

C<sub>6</sub>: 24 valence electrons  
 H<sub>12</sub>: 12  
 O<sub>6</sub>: 36  
 72 valence electrons



1.22

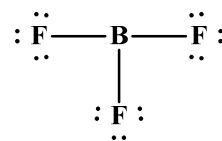
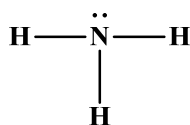
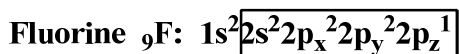
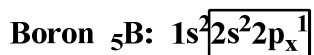
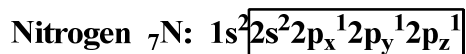

(Lewis structures)

NH<sub>3</sub> : In the nitrogen atom, one s orbital (2s) and three p orbitals (2p<sub>x</sub>, 2p<sub>y</sub>, 2p<sub>z</sub>) are mixed to give four equivalent hybridized orbitals, sp<sup>3</sup>. Three of the four sp<sup>3</sup> orbitals with one electron each form single covalent bonds with 1s orbital of each hydrogen atom. The fourth sp<sup>3</sup> orbital contains two non-bonding electrons.

According to the VSEPR theory, lone pair – covalent bond > covalent-covalent bond repulsions , therefore the geometry of NH<sub>3</sub> is pyramidal.

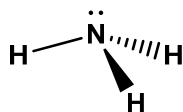

BH<sub>3</sub> : one s orbital (2s) and two p orbitals (2p<sub>x</sub>, 2p<sub>y</sub>) of boron atom give upon hybridization, three equivalent hybridized orbitals, sp<sup>2</sup> with one electron each, which form a covalent bond with the 2p<sub>z</sub> orbital of each fluorine atom.

According to the VSEPR theory, the three angles are equivalent (120°). The resulting geometry is planar trigonal for the three covalent bonds to be maximally spaced.

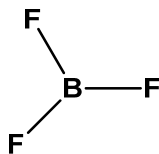

1.23

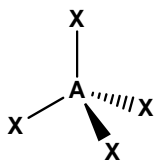

The geometry is tetrahedral ( $AX_4$ ), where "A" is the central atom and "X" is the surrounding atom.  
e.g.  $CH_4$

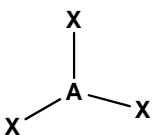

The geometry is planar trigonal ( $AX_3$ )  
e.g.  $H_2C=CH_2$ ;  $BF_3$



The geometry is linear ( $AX_2$ )  
e.g.  $H-C\equiv C-H$

1.24

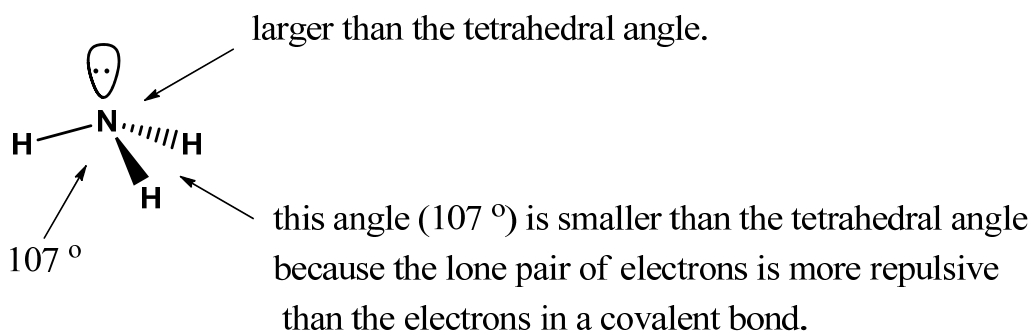

1.25

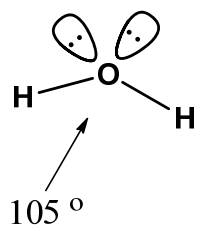

Two lone pairs of electrons are highly repulsive requiring a larger angle, therefore diminishing the H-O-H angle.

1.26

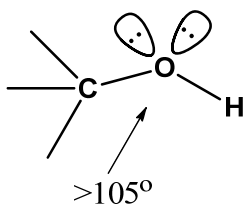

Although the two lone pairs repulsion is similar to that in  $\text{H}_2\text{O}$ , the larger size of the  $\text{C}$  group requires more space therefore opening the  $\text{C-O-H}$  angle to more than  $105^\circ$  but still less than the tetrahedral angle.

1.27

$sp$ : 2 ;       $sp^2$ : 3;       $sp^3$ : 4

1.28

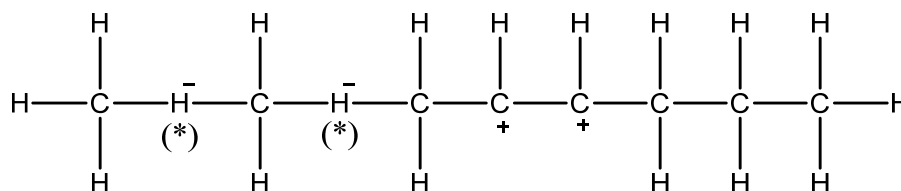

$$\begin{aligned} \text{C}_8\text{H}_{18}: \text{ number of electrons} &= 8 \times 4 = 32 (\text{C}_8) \\ &18 \times 1 = 18 (\text{H}_{18}) \\ \text{Total} &= 50 \end{aligned}$$

Formal charges are shown.

1.29

The equivalent of the octet rule for first row elements, is two electrons. The (\*) H atoms in answer to problem 1.28 disobey this equivalent of the octet rule. The octet rule is not obeyed by the two carbon atoms with formal charges.

1.30

The ability to bisect an object by a mirror plane, so that one half of the object is reflected perfectly by the other half demonstrates that the object will be identical to its mirror image.

The two sides of the tea cup have identical images whereas,  $\alpha$ - or  $\beta$ -glucose, L or D are not identical to their mirror images.

1.31

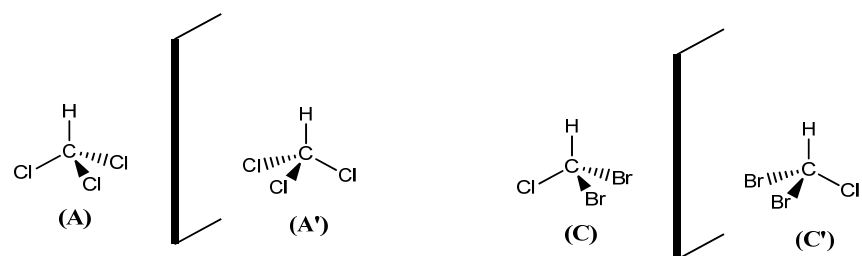

A and A' are superimposable

C and C' are superimposable

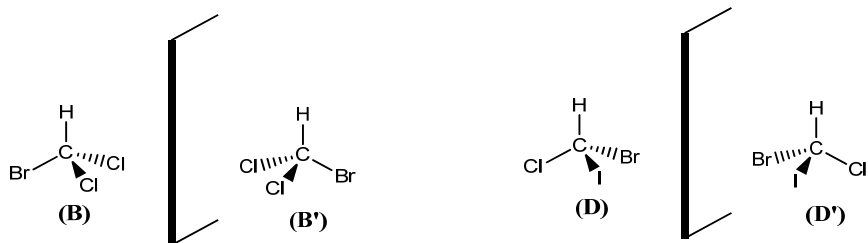

B and B' are superimposable

D and D' are not superimposable

If the arrangement around the central atom was in a single plan, all four molecules should be identical to their mirror images. In this case, the two slices obtained with a two sided mirror are identical.

1.32

The mechanisms that sustain life must have a handed quality so as to distinguish mirror image molecules, just as your right hand can distinguish another person's right and left hands.

1.33

All asymmetric objects ( or molecules) lack elements of symmetry and therefore are not superimposable with their mirror images. In addition, slicing an asymmetric molecule by a two sided mirror leads to images that are not identical.

1.34

Right and left hands are mirror images that are not superimposable. Every molecule which behaves as the right and left hands is described as a "chiral molecule".

1.35

The word "chiral" can only be used to describe the properties of a single molecule which is not identical to its mirror image. The presence or absence of the mirror image has nothing to do with the designation "chiral".

1.36

Your left and right hands are mirror image related and can be only distinguished by a probe (your friend's right hand) which is itself capable of existing in mirror image forms. Following

the same principle, enzymes which are chiral are able to distinguish one mirror image from another and to choose specifically one of the mirror images of glucose. However, does this fact about shaking hands predicts that D-glucose but not L-glucose is used rather than L-glucose but not D-glucose?

No: as your friend's right hand fit better your right hand so would your friend's left hand fit in the same identical way your left hand. It all depends on the chirality of the enzymes.

1.37

Since most enzymes are specific and can only catalyze reactions involving one enantiomer (e.g. D-glucose) to the absolute exclusion of the other (e.g. L-glucose), it can be expected experiments to show that the helical regions of the structure of the enzymes have only one handedness.

1.38

All aspects of stereoisomerism involve pairwise relationships just as mirror images can only involve comparisons of a pair.

1.39

Two molecules that are enantiomers are identical in all aspects except in an environment that is chiral. Therefore enantiomers must have identical solubilities in water. Two diastereomers have different physical and chemical properties and therefore may have differing solubilities in water.

1.40

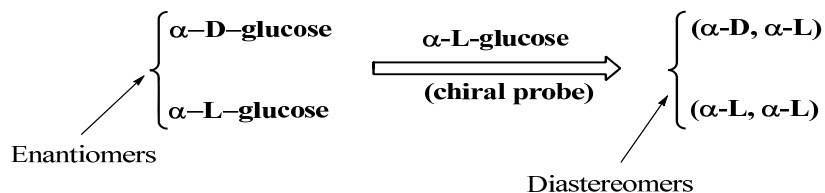

$\alpha\text{-D-glucose}$  and  $\alpha\text{-L-glucose}$  are related as mirror images and therefore are *enantiomers*. Their interactions with one molecule of  $\alpha\text{-L-glucose}$  leads to formation of two new molecules:  $(\alpha\text{-D}, \alpha\text{-L})$  and  $(\alpha\text{-L}, \alpha\text{-L})$ . The two pairs are stereoisomers, which are not mirror images and therefore are *diastereomers*. Therefore, the two bonded pairs  $(\alpha\text{-D}, \alpha\text{-L})$  and  $(\alpha\text{-L}, \alpha\text{-L})$  will have different properties.

1.41

The atoms in the four isomers are connected together identically. Therefore, there is no pair of constitutional (structural) isomers.

A pair of molecules with the same formula are constitutional isomers if the atoms in each isomer are connected together in different ways.

1.42

$\alpha\text{-D}/\alpha\text{-L-glucose}$  and  $\beta\text{-D}/\beta\text{-L-glucose}$  are pairs of enantiomers and are expected to have identical properties. This prediction is an agreement with the experimental data reported in

Fig.1.7. Pairs of enantiomers have identical melting temperatures and  $[\alpha]_D$  values of opposite sign .

Pairs of diastereoisomers ( $\alpha$ -D/ $\beta$ -D;  $\alpha$ -D/ $\beta$ -L;  $\alpha$ -L/ $\beta$ -D;  $\alpha$ -L/ $\beta$ -L) have different melting temperatures and different  $[\alpha]_D$  values.

1.43

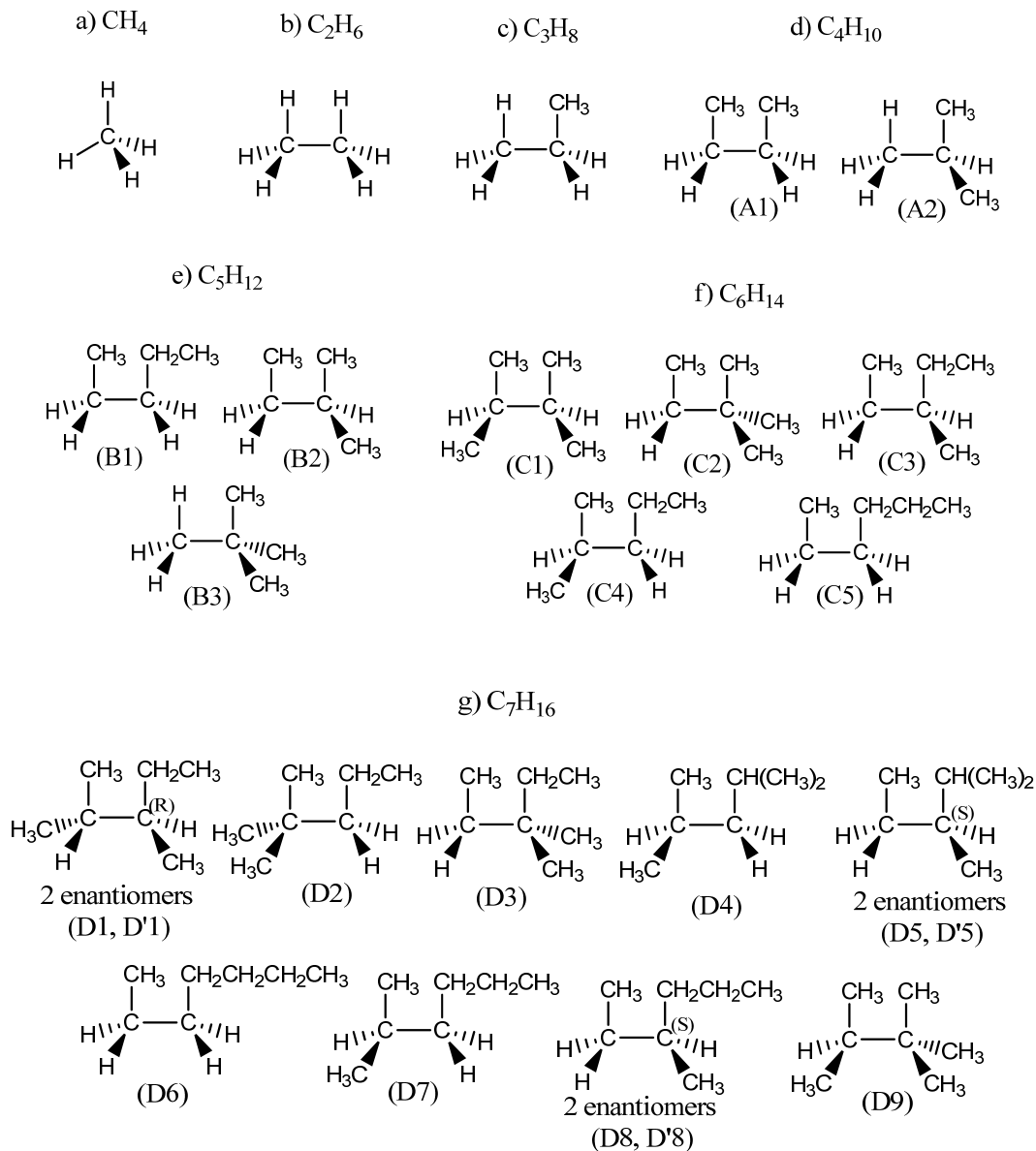

1.44

- A1/A2; B1/B2/B3; C1/C2/C3/C4/C5; D1/D2/D3/D4/D4/D5/D6/D7/D8 are groups of *constitutional (structural) isomers*. They have identical formulas but differ by the ways that atoms are connected together.

For each pair of constitutional isomers, the physical properties such as boiling point or melting point, could be different.

- D1/D'1, D5/D'5 and D8/D'8 are pairs of *enantiomers* (R/S).  
For each pair of enantiomers, the physical properties must be identical.

A1/A2, B1/B2, B1/B3, B2/B3, C1/C2, C1/C3, C1/C4, etc., D1/D2, D2/D3, etc. are pairs of constitutional isomers and may therefore have different physical properties.

1.45

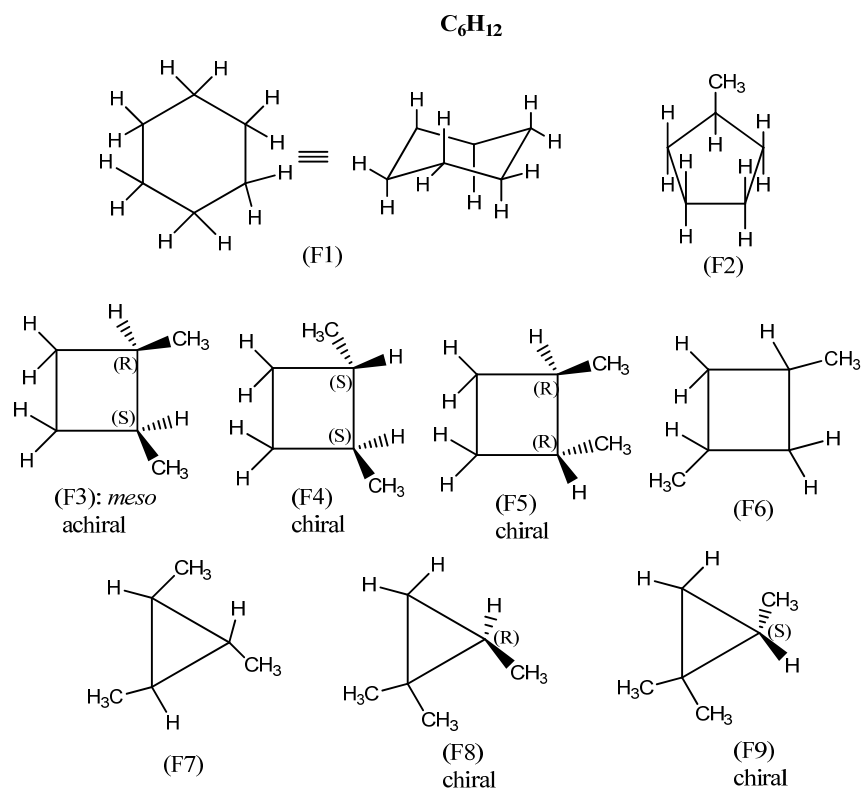

- F1/F2, F1/(F3or F4orF5), F1/F6, F1/F7, F1/(F8orF9), etc. are pairs of *constitutional isomers*.
- F4/F5 and F8/F9 are pairs of *enantiomers*.
- F3/F4, F3/F5 are pairs of *diastereomers*.

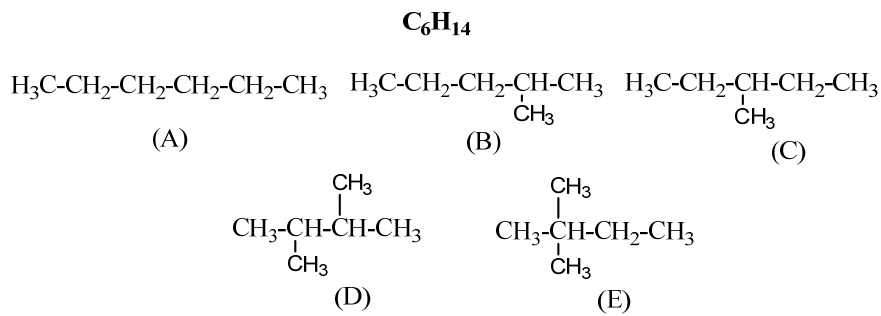

A/B, A/C, A/D, A/E, B/C, B/D, B/E; C/D; C/E; D/E are pairs of *constitutional isomers*.

1.46

No answer required.

1.47

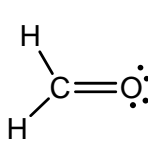
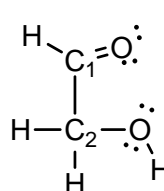
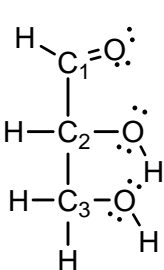
	atom	geometry	hybridization
	C	planar	$sp^2$
	O	planar	$sp^2$
	C1	planar	$sp^2$
	O1	planar	$sp^2$
	C2	tetrahedral	$sp^3$
	O2	tetrahedral	$sp^3$
	C1	planar	$sp^2$
	O1	planar	$sp^2$
	C2, C3	tetrahedral	$sp^3$
	O2, O3	tetrahedral	$sp^3$

1.48

- Formaldehyde has a plane of symmetry

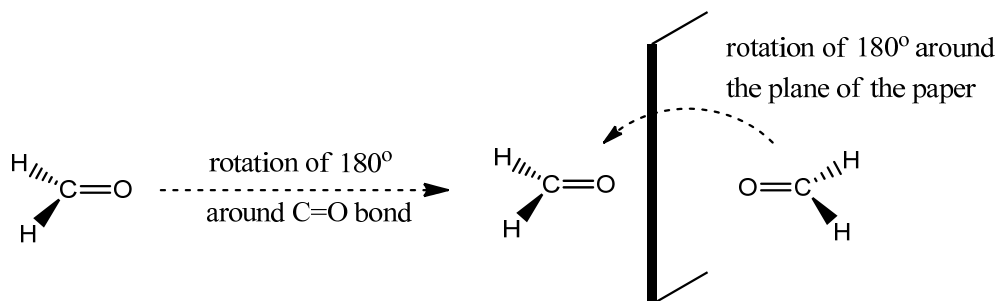

- Hydroxyacetaldehyde is not chiral



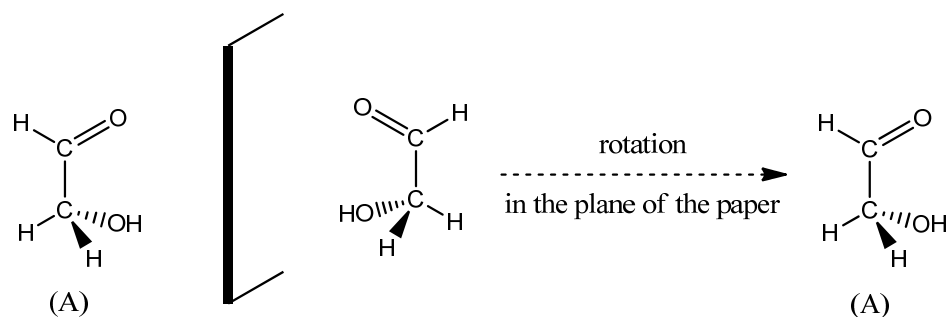

- Glyceraldehyde is chiral (no element of symmetry is present)

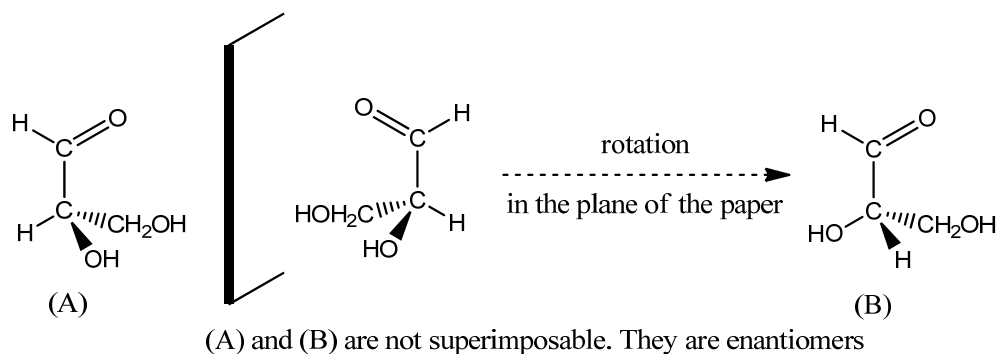

1.49

An achiral probe interacts equally with each of the two enantiomers giving products with the same chirality .

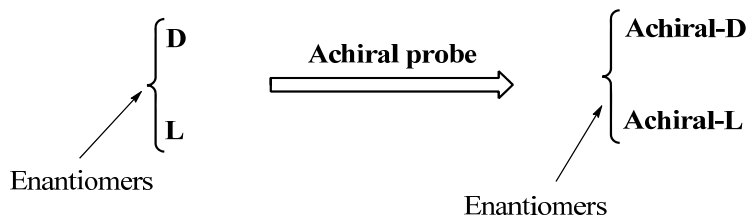

A chiral probe (L) interacts with two enantiomers L/D, giving two diastereoisomers (L,L) and (L,D)

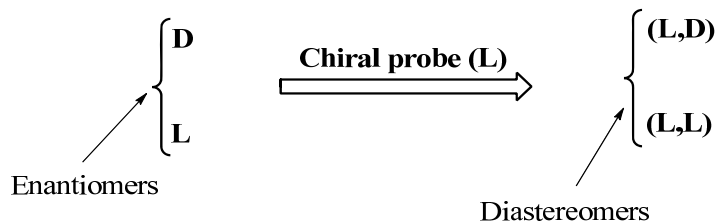

1.50

All processes that separate enantiomers are based on interaction of a mixture of the two enantiomers with a chiral probe, therefore, converting them into two diastereomers which have different physical properties and can be separated.

1.51

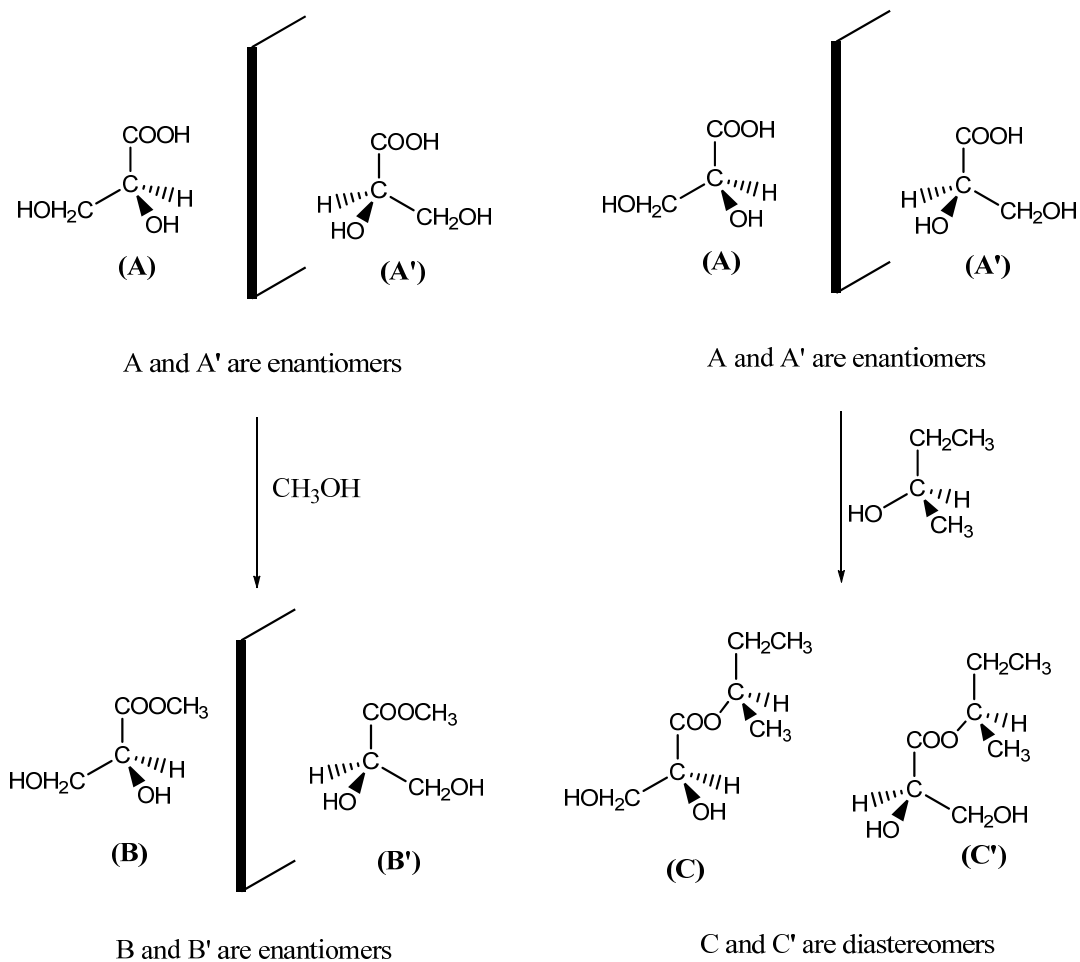

1.52

- a)  $\beta$ -D-glucose and  $\beta$ -L-glucose are related as mirror images, just as the mirror image crystals that Pasteur encountered in his laboratory. Just as he could distinguish the crystals, your hands can distinguish the enantiomeric models.
- b) Achiral molecules such as  $\text{CH}_4$ ,  $\text{C}_2\text{H}_6$ ,  $\text{C}_3\text{H}_8$ , etc. will give identical interaction with the two enantiomers of  $\beta$ -glucose; whereas interaction of chiral molecules such as  $\text{C}_4$ ,  $\text{D}_4$ ,  $\text{I}_4$  (see answer to problem 1.43) with  $\beta$ -D and  $\beta$ -L-glucose will result in two different three-dimensional structures (diastereomers) with different properties.

This experiment is in perfect agreement with the results presented in Fig.1.8.

1.53

The two helices are not superimposable and each one is a representation of the left and right handed circularly polarized light. The vector sum of these circular polarizations (left and right helix) is in the identical plane as the incoming light. Upon interaction with one of the glucose enantiomer, the vector sum will be rotated by an angle to the right or the left of the original

position therefore generating optical activity. You can observe that the wire helices you made interact differently with one of the glucose enantiomers.

1.54

A racemic mixture contains equal amounts of two enantiomers. Whatever effect one of the enantiomers had on the light, the other enantiomer would have the opposite effect and these effects would cancel each other.

Although the experimental observation for a solution of an achiral molecule is the same as that for the racemic mixture, the reasons behind these results are different. In the case of an achiral molecule, the left and right handed circular polarized light would pass unchanged through the solution so that the plane of the polarized light would be unchanged from the original angle. Whereas in the presence of a racemic mixture, there are two opposite effects which cancel each other.

1.55

The terms “dextrorotatory” and “levorotatory” are related only to the direction in change of the plane of polarization from its original position. Therefore, Pasteur would have reached the same conclusion with inversion of assignments.

1.56

$$[\alpha]_D = +100^\circ; l = 1 \text{ dm}; C = 1\text{g}/100 \text{ mL} = 1\text{g}/100\text{cm}^3$$

$$\alpha_d = [\alpha]_D l C / 100 = (+100) \cdot 1 \cdot 1 / 100 = +1^\circ$$

$$\text{for the enantiomer } ([\alpha]_D = -100^\circ) \text{ therefore, } \alpha_l = (-100) \cdot 1 \cdot 1 / 100 = -1^\circ$$

1.57

No: D or L correspond to information used to represent molecular structure whereas, dextrorotatory (d) and levorotatory (l) are optical activity properties.

A molecular structure designated as D may exhibit d or l optical activity.

1.58

Interaction of a racemic mixture with a left handed circular polarized light would give two different effects which do not cancel each other. Therefore, it might be possible to use a left handed circularly polarized light as a chiral exciting agent to induce a chemical or physical change for separating a mixture of enantiomers.

1.59

Carbon bonding to four different entities is not sufficient to account for the phenomenon of mirror image isomerism when elements of symmetry are present.

Four different groups bonded to carbon could be possible without mirror image isomerism if there is a plane of symmetry ( e.g. meso-tartaric acid).

1.60

a) Thalidomide has the following structure:

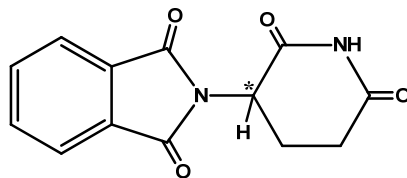

since it has a stereogenic carbon atom(\*), it exists as two enantiomers:

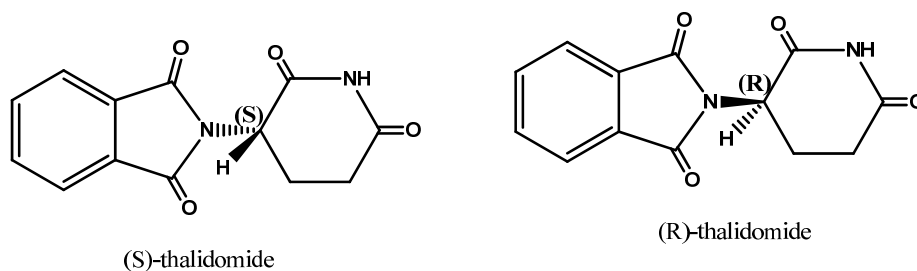

(R)- thalidomide is effective against morning sickness whereas the (S)-enantiomer is teratogenic.

b) Carvone has the following structure:

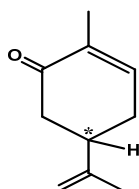

It exists in two enantiomeric forms:

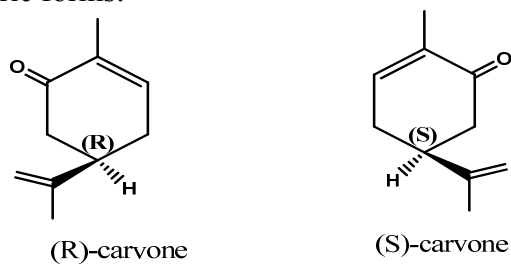

The fact that the two enantiomers of carvone or thalidomide respond differently means that our body contains chiral receptors, which interact with the two enantiomers allowing them to give differing responses.

Note that interaction of the two enantiomers with a chiral probe converts them to a diastereoisomeric relationship.

1.61

If specific interactions with cellulose occur, the two enantiomers of thalidomide dissolved in a solvent will pass along the tube filled with cellulose (chiral molecule) at different rates, and therefore appear at the end of the tube at different times. If there is no interaction, the two enantiomers would elute at the same rate.

The following experiment can be performed:

- Elute a solution of each enantiomer along the tube, filled with cellulose, and connected to a detector which allows measuring the elution time of each pure enantiomer ( $t_R$ ,  $t_S$ ).
- Elute the racemic mixture along the tube, and measure the elution times (two peaks are observed) and make the assignment based on the information from (a).

1.62

- False: the designation D has no relationship to d, l, R or S.
- False: the determination that a chiral molecule is d or l depends on the index of refraction with circularly polarized light.
- True.
- True.
- True
- True

1.63

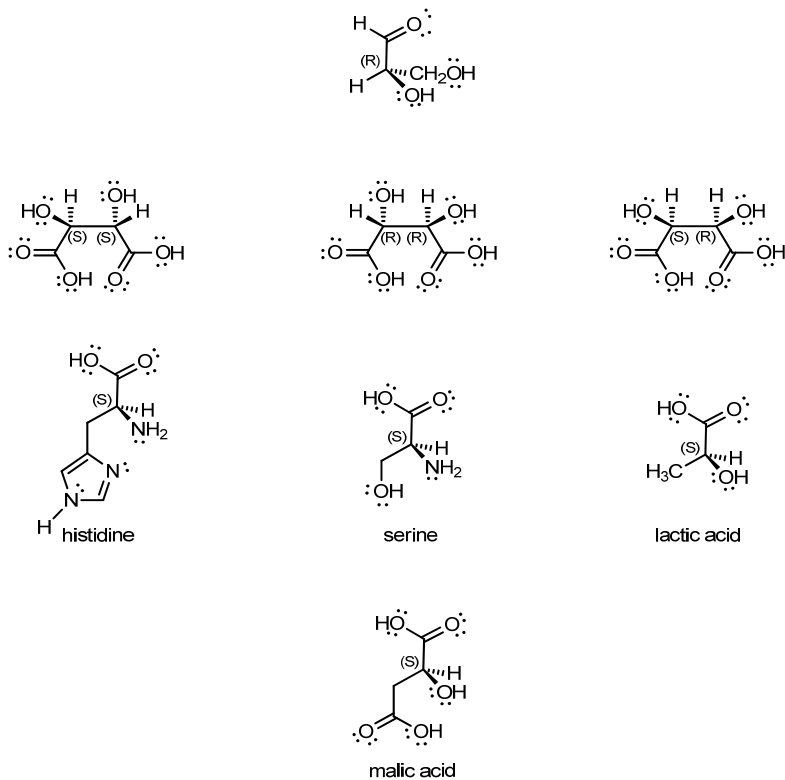

## 1.64

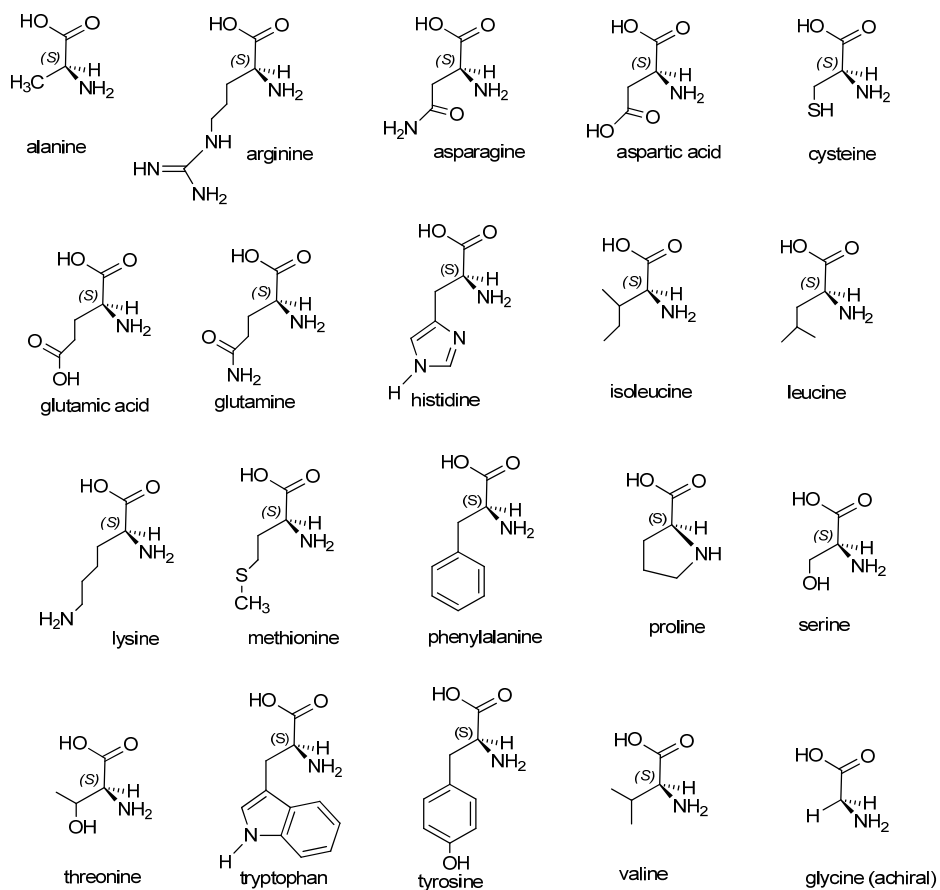

## 1.65

- a) Although this molecule has two carbon atoms for which the assignments (R) and (S) could be made, the presence of a plane of symmetry forces it to be superimposable to its mirror image. As a result, the molecule is achiral.

“*meso*” is used to name molecules, in which there are more than one carbon with the same four different groups, and with planes of symmetry.

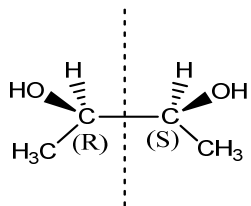
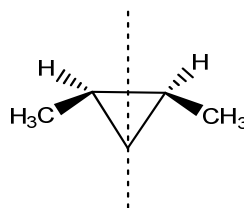
*meso*-butane-1,2-diol*meso*-1,2-dimethylcyclopropane

- b) “*meso*” molecules are achiral and would not show any optical activity. As for other achiral molecules in which it is not possible to assign (R) or (S), *meso* molecules are optically inactive.

1.66

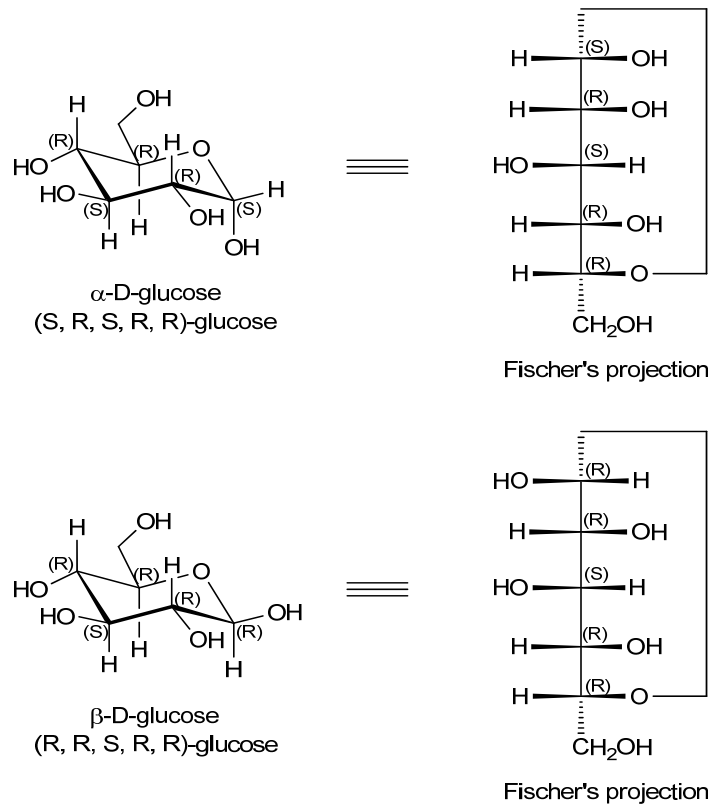

Each D-glucose unit in both polymers (starch and cellulose) keep the same R,S- nomenclature as in single monomers.

1.67

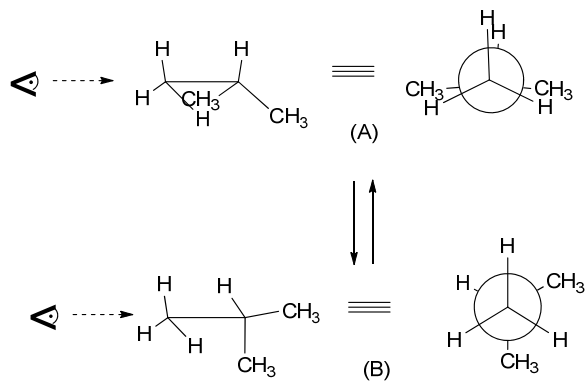

Conformers of 2-methylpropane

Further rotation of (B) gives (A). Then, only two conformations are possible.

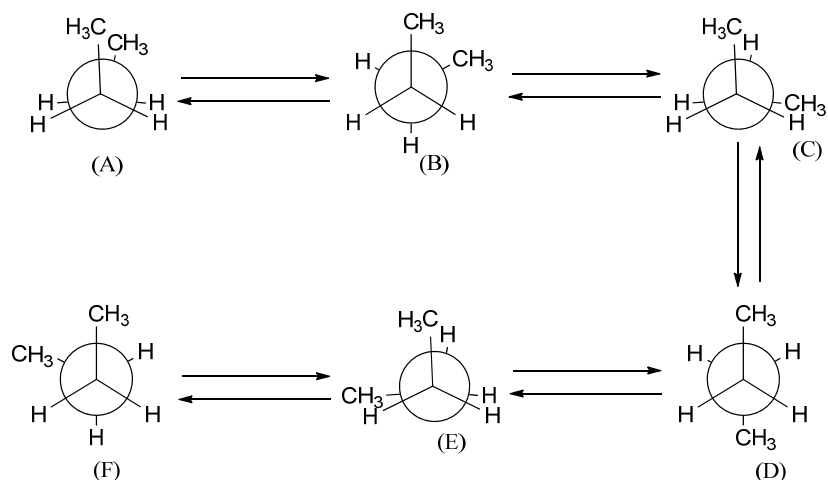

(B, F) and (C, E) are pairs of enantiomers; others are diastereomers.

1.68

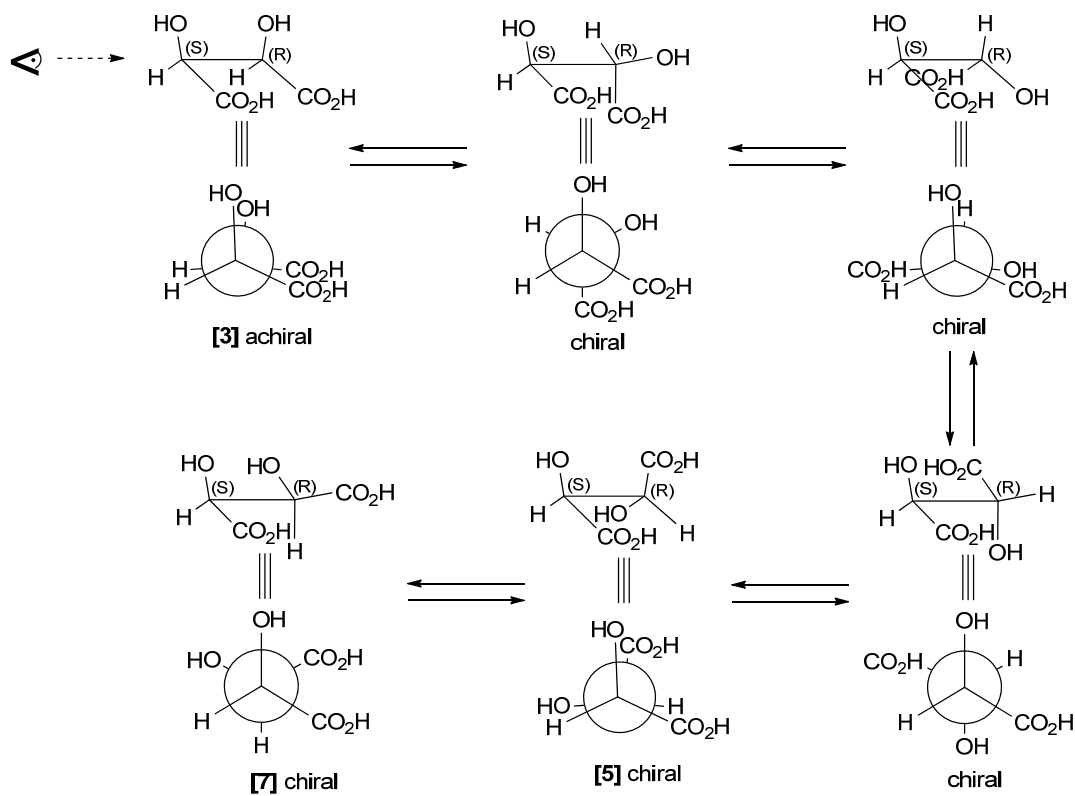

[3] is identical to its mirror image due to the presence of a plane of symmetry. Except [3], all other conformational isomers do not have an identical mirror image.

1.69

Only rotational motions about bonds are necessary to interconvert conformational isomers. Therefore, no change in absolute configurations (R/S) is expected (see answer to problem 1.68).





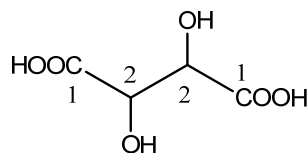

2.5

- Above 3000  $\text{cm}^{-1}$  corresponds to the band of H-bonded to the oxygen atom (O-H);
- From 2800-3000  $\text{cm}^{-1}$  corresponds to C-H;
- About 1000  $\text{cm}^{-1}$  corresponds to C-O-C

2.6

According to the fact that each different carbon atom should give only one line in the carbon NMR spectrum, the following number of lines could be predicted for the isomers of  $\text{C}_8\text{H}_{18}$ .

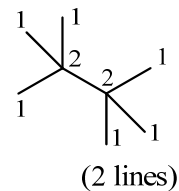
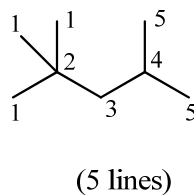
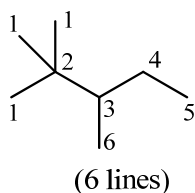
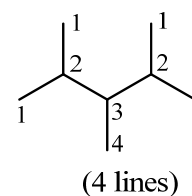
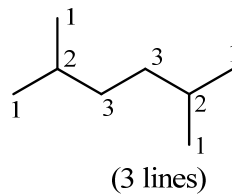
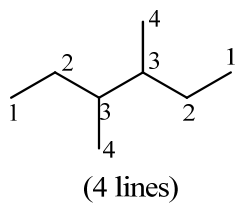
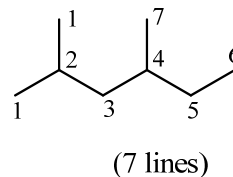
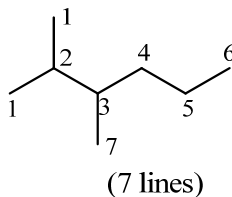
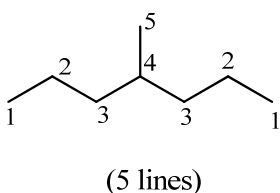
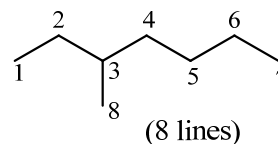
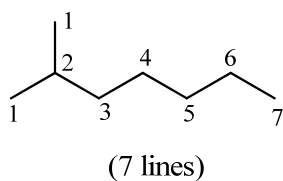
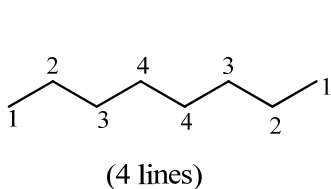

### Estimation of $\delta$ ( $^{13}\text{C}$ ):

$\delta$  (ppm): (higher field)  $\text{CH}_3$ - <  $\text{RCH}_2$ -;  $\text{R}_2\text{CH}$ -;  $\text{R}_3\text{C}$ - (lower field)

2.7

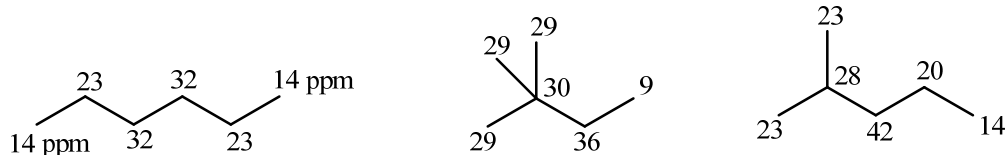

2.8

Chemical shifts arise because the magnetic field,  $\mathbf{B}$ , actually experienced by a nucleus (C or H) differs slightly from the external field  $\mathbf{B}_0$ . In an atom,  $\mathbf{B}$  is slightly smaller than  $\mathbf{B}_0$  because the external field ( $\mathbf{B}_0$ ) causes the electrons to circulate within their orbitals; this induced motion, much like an electric current passing through a coil of a wire, generates a small magnetic field  $\mathbf{B}_e$  in the opposite direction to  $\mathbf{B}_0$ . The nucleus is thus shielded from the external field by its surrounding electrons ( $\mathbf{B} = \mathbf{B}_0 - \mathbf{B}_e$ )

$$B_e = B_0 \cdot \sigma; \text{ this leads to } B = B_0(1 - \sigma)$$

Where  $\sigma$  is called *shielding constant* and depends on the local electron density. As a result of the shielding effect, the resonance of the nucleus (C or H) occurs at the following frequency:

$$\nu = \frac{\gamma B_0}{2\pi} (1 - \sigma) \propto (1 - \sigma)$$

The chemical shift ( $\delta$ ) is defined as the difference between the nucleus of interest frequency ( $\nu$ ) and the frequency ( $\nu_{\text{ref}}$ ) of a reference nucleus.

$$\delta = 10^6 \frac{(\nu - \nu_{\text{ref}})}{\nu_{\text{ref}}} \approx 10^6 (\sigma_{\text{ref}} - \sigma)$$

$\delta$  is proportional to  $(\sigma_{\text{ref}} - \sigma)$ . A decrease of  $\sigma$  (greater deshielding) leads to a decrease of magnetic field  $\mathbf{B}_e$  and to an increase of the chemical shift  $\delta$ .

2.9

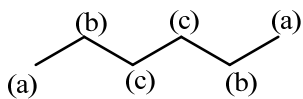

CH<sub>3</sub> (a): 3 lines  
 CH<sub>2</sub> (b): 4x3 = 12 lines  
 CH<sub>2</sub> (c): 3x3 = 9 lines

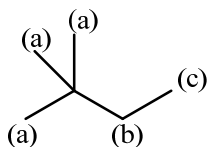

CH<sub>3</sub> (a): 1 line  
 CH<sub>2</sub> (b): 4 lines  
 CH<sub>3</sub> (c): 3 lines

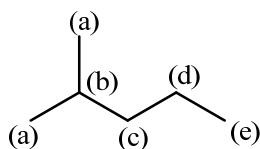

CH<sub>3</sub> (a): 2 lines  
 CH (b): 7x3 = 21 lines  
 CH<sub>2</sub> (c): 3x2 = 6 lines  
 CH<sub>2</sub> (d): 4x3 = 12 lines  
 CH<sub>3</sub> (e): 3 lines

The lower field signal between 1.48 and 1.60 ppm corresponds to CH- proton which is connected to two CH<sub>3</sub> and one CH<sub>2</sub> groups. Actually, if the resolution were high enough and assuming that  $J(\text{CH}-\text{CH}_3)$  is higher than  $J(\text{CH}-\text{CH}_2)$ , the signal for this hydrogen atom (CH) would be first split into 7 lines by the 6H atoms of 2CH<sub>3</sub>. Each of these lines would be further split into 3 lines by the 2H atoms of CH<sub>2</sub> group, giving a total of 21 lines.

But under certain conditions,  $J(\text{CH}-\text{CH}_3) \approx J(\text{CH}-\text{CH}_2)$ , therefore, the 6H atoms of the two CH<sub>3</sub> groups and the 2H atoms of the CH<sub>2</sub> group may act as one type of proton, leading to a signal with 9 lines.

2.10

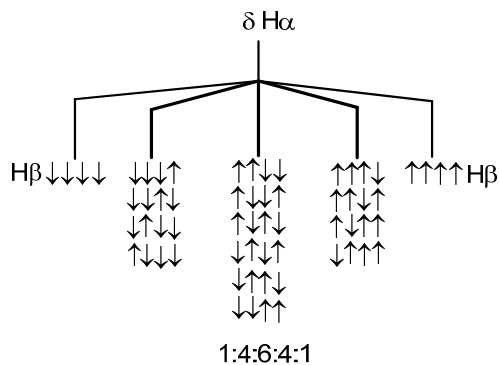

2.11

a)

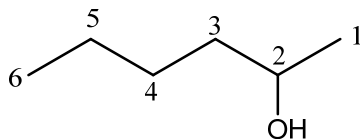

2-hexanol is expected to give a  $^{13}\text{C}$  spectrum with 6 lines. Therefore, its spectrum should be (a). The five lines within 40 ppm correspond to C1, C3-C6 and the low field signal at around 68 ppm corresponds to the more deshielded carbon C2.

The signals could be assigned as follows:

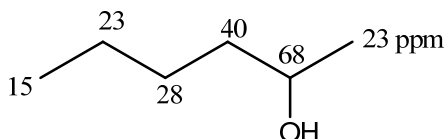

b)

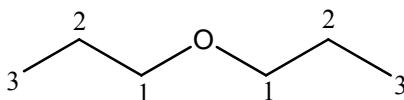

The spectrum of dipropyl ether is expected to have 3 lines and should be (b). The deshielded carbon atom (C1) corresponds to the signal at around 72 ppm; C2 and C3 are at  $\approx$  24 and  $\approx$  10 ppm, respectively.

c)

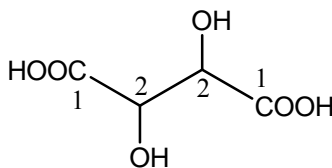

The spectrum of any tartaric acid is expected to have 2 lines and should therefore be (c) with C1 (the more deshielded) at  $\approx$  175 ppm and C2 at  $\approx$  72 ppm.

d) The remaining spectrum (d) must be assigned to glucose. D-glucose spectrum is expected to have 6 lines. However, there are apparently too many lines. An explanation is that glucose in  $\text{H}_2\text{O}$  undergoes isomerization and is therefore present as a mixture of diastereomers ( $\alpha$  and  $\beta$ ). This process is known as mutarotation as discussed in chapter 3.

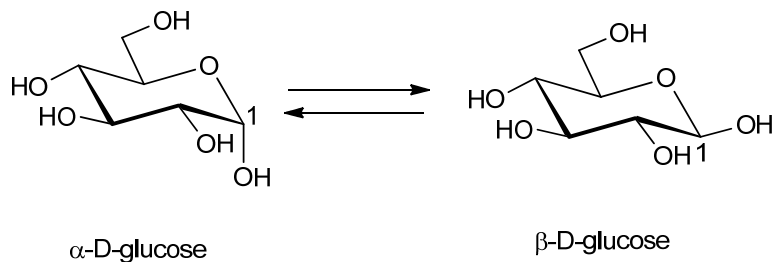

The two low field signals at around 96 and 92 ppm correspond to C1 of the two diastereomers.

2.12

- a) The NMR spectrum 1 is composed of five groups of proton signals in the following ratio 1:1:6:3:3 with a total of 14 protons, Therefore, it could be 2-hexanol.

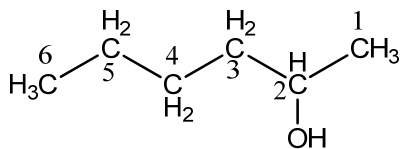

**Assignment of proton signals (approximate)**

- 0.90 ppm (triplet, 3 protons, H-6)
- 1.18 ppm (doublet, 3 protons, H-1)
- 1.40 ppm (multiplet, 6 protons, H-3,4,5)
- 1.90 ppm (singlet, 1 proton, OH)
- 3.80 ppm (multiplet, 1 proton, H-2)

- b) Spectrum 2 has three groups of signals in the ratio 4:4:6 (14 protons) and could be dipropyl ether.

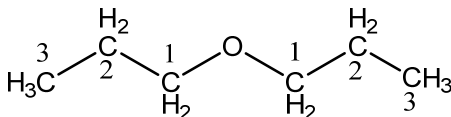

**Assignment of proton signals (approximate)**

- 0.90 ppm (triplet, 6 protons, H-3)
- 1.60 ppm (multiplet, 4 protons, H-2)
- 3.33 ppm (triplet, 4 protons, H-1)

- c) Spectrum 3 shows two signals: one corresponds to HDO and the other with two protons. This could be tartaric acid.

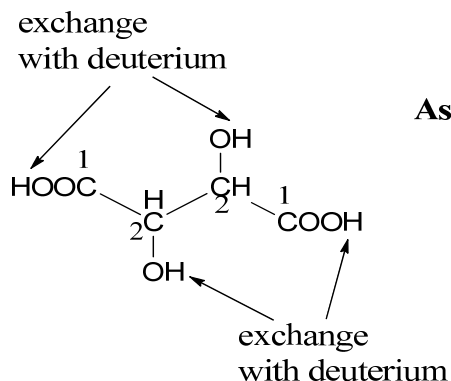

**Assignment of proton signals (approximate)**

- 4.74 ppm (singlet, 2 protons, H-2)
- 4.90 ppm (singlet, HDO from rapid exchange of COOH and OH with D<sub>2</sub>O)

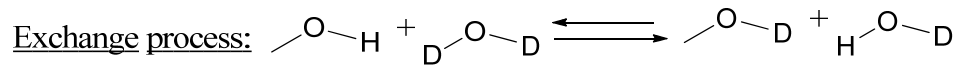

- d) Spectra 4 and 5 are similar and differ only in the ratio of intensities (see low field signals). They must be assigned to varying proportions of  $\alpha$  and  $\beta$ -glucose (Fig. 3.11 in chapter 3).

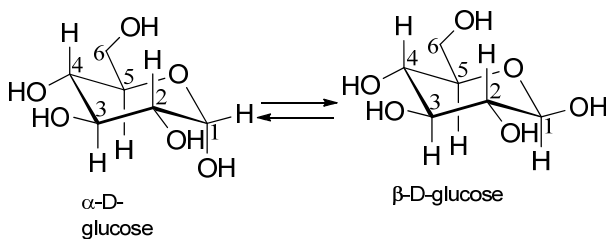

**Assignment of proton signals (approximate)**

- the doublets at 4.50 ppm and 5 ppm correspond to the anomeric proton H-1 of both diastereomers ( $\alpha$ ,  $\beta$ ).
- 4.70 ppm (singlet, HDO from rapid exchange of OH groups with  $\text{D}_2\text{O}$ )
- all other protons that do not exchange with  $\text{D}_2\text{O}$  (H-2,3,4,5,6), give a complex multiplet below 4 ppm.

## Chapter 3

### 3.1

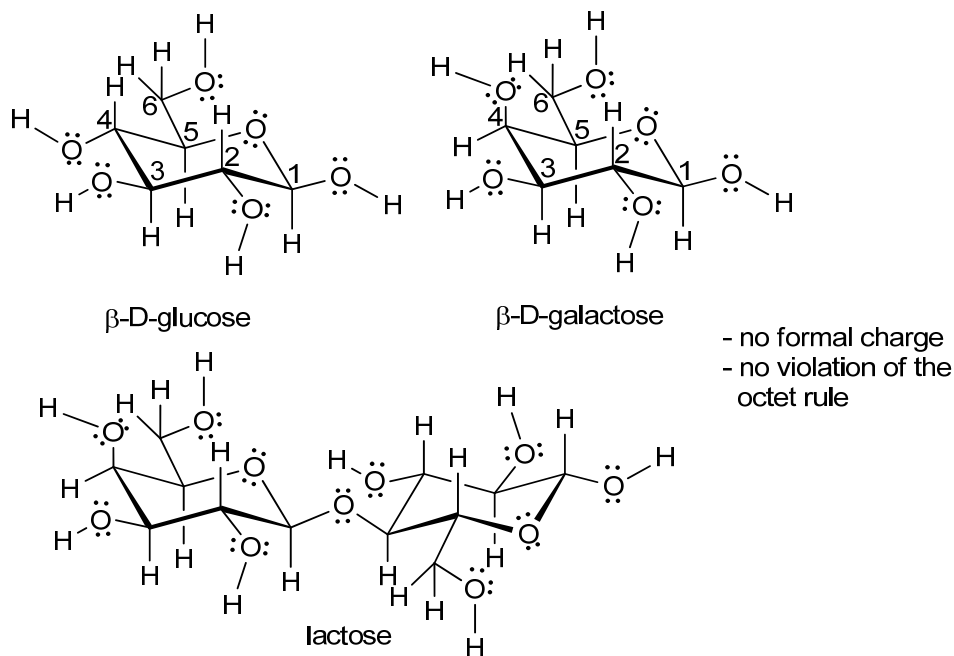

### 3.2

D-glucose and D-galactose have the same formula ( $C_6H_{12}O_6$ ), the same connection through atoms but differ only by their shapes (three-dimensional structures). Therefore, they are *stereoisomers*.

They differ only by the orientation of the  $-OH$  in C4, which is upward in D-galactose and downward in D-glucose. Therefore, they are not *enantiomers*, which means they are *diastereomers*.

### 3.3

Even if D-glucose and D-galactose were enantiomers, they will still be different in vivo because biological processes are stereospecific and are able to distinguish enantiomers.

### 3.4

The differing chiral carbon atom is C4. Its configuration is (R) for D-glucose (see answer to problem 1.66). Therefore, it will be assigned the (S) configuration for D-galactose.

### 3.5

D-glucose has five chiral carbon atoms. By excluding the anomeric carbon C1, which should have the same configuration for all  $\beta$ -isomers, the number of  $\beta$ -isomers should be:  $2^4 = 16$  (number of isomers =  $2^n$ , n = number of chiral carbon atoms). There should be 8 *diastereomers*, each with a non-identical mirror image.



3.6

Because the interior angle of a pentagon (five-membered ring) is  $108^\circ$  which is close to the tetrahedral angle ( $\approx 109^\circ$ ).

3.7

The flat cyclohexane ring is represented as follows:

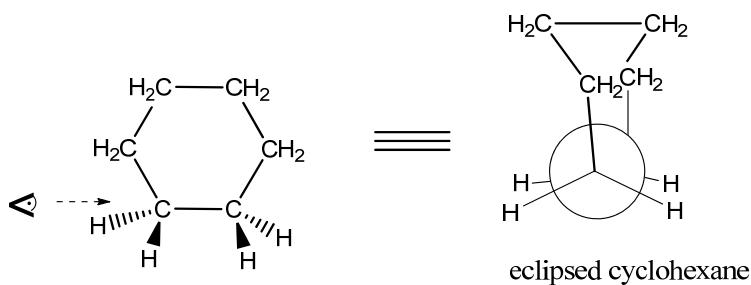

In eclipsed cyclohexane, the electron pairs in the eclipsed bonds repel each other, therefore generating a torsional strain in the ring. Only one set of eclipsed pairs is shown above.

3.8

Two types of strains generally account for the stability of alkanes and related compounds: the torsional strain and the steric strain.

In ethane ( $C_2H_6$ ), the differing stability between eclipsed and gauche conformations is only due to torsional strain (no steric strain). In higher alkanes such as butane, steric strain is superimposed on the torsional strain.

- ethane

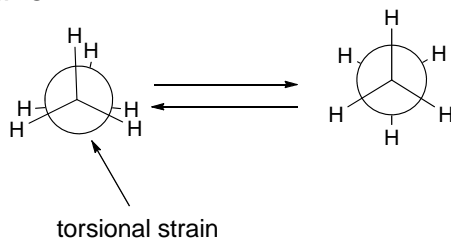

- n-butane

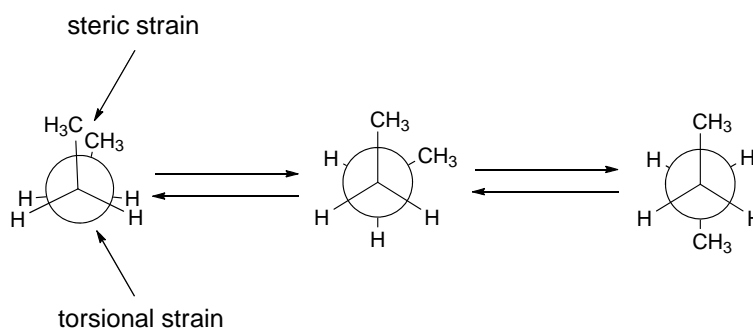

## 3.9

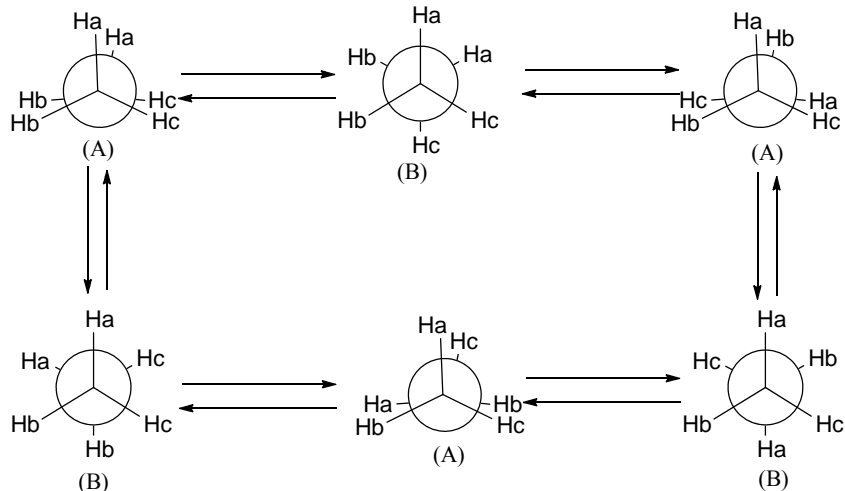

Newman projections show that ethane exists momentarily in alternated repeating conformations with torsional strain (eclipsed) and without torsional strain (gauche).

## 3.10

The chair form of cyclohexane is represented as follows:

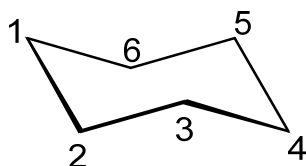

Looking through C2-C3 and C6-C5 bonds gives the following Newman projections:

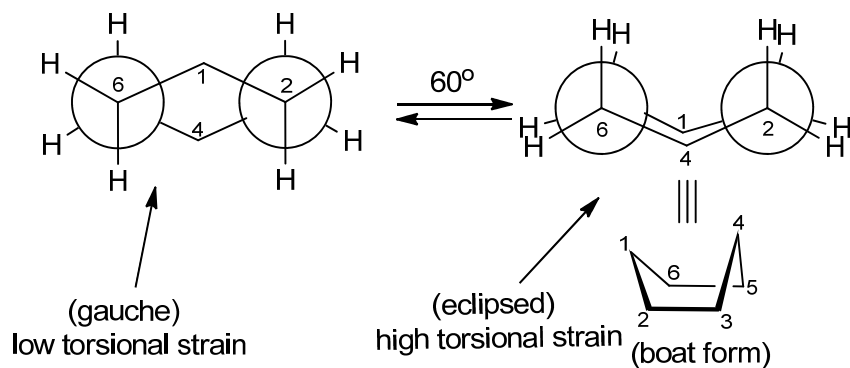

## 3.11

Since conformational isomers differ in stability, it could be possible to separate them using low temperature experiments.

For example, conformational isomers (see above) of n-butane have energy in the following order:  $E_A < E_B \ll E_C < E_D$ .

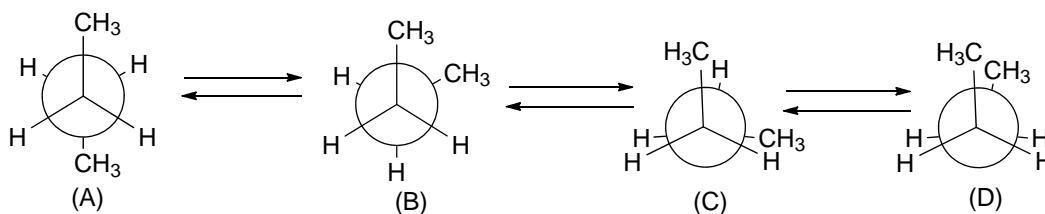

A and B are the most stable. If the temperature is low enough, the time to interconvert A and B could be long enough to separate them from each other. The rate of interconversion could be kept under control following Arrhenius equation ( $k = Ae^{-E_{act}/RT}$ , see section 6.11 in chapter 6) if one knows the activation energy (energy of to the barrier). However, such an experiment could not separate B and its enantiomer, which must be present in equal amounts.

Eclipsed conformers such as C and D are highly unstable and could not be separated using the above experiment.

3.12

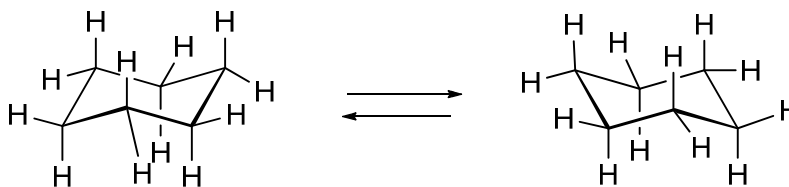

Both conformations are identical

3.13

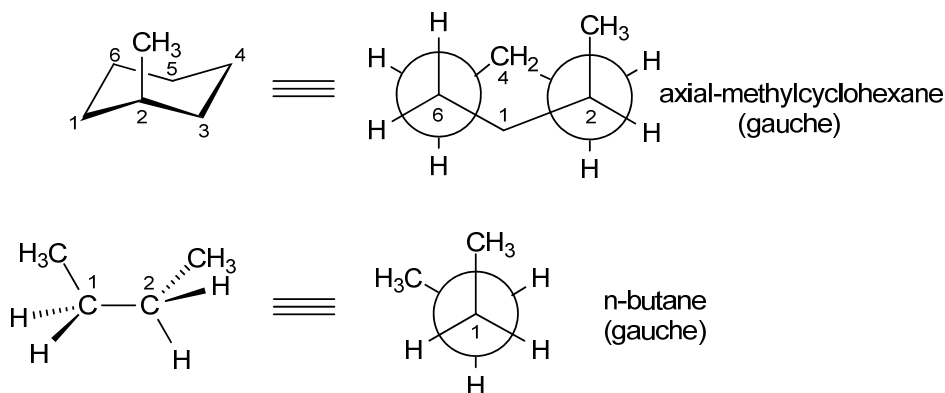

The two  $\text{CH}_3$  groups of n-butane in *gauche* conformation find parallel in the axial- $\text{CH}_3$  and  $\text{CH}_2$  in the 4-position of methylcyclohexane. The same parallel occurs between axial- $\text{CH}_3$  and  $\text{CH}_2$  in the 6-position.

3.14

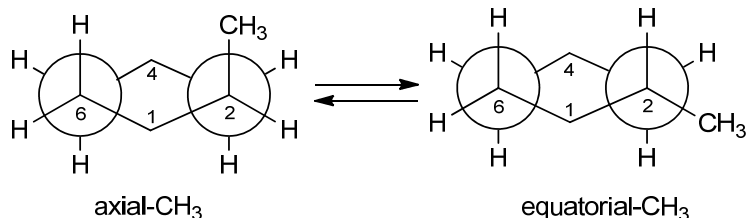

Steric strain would be observed between axial-CH<sub>3</sub> and the two CH<sub>2</sub> groups in the 4- and 6-positions of the cyclohexane ring. This effect is removed when the CH<sub>3</sub> group has an equatorial orientation, which the *anti* conformation of n-butane has parallels to.

3.15

Yes. There are two other conformational isomers of n-butane non shown in the text: one is eclipsed and another is gauche which is present as a pair of enantiomers.

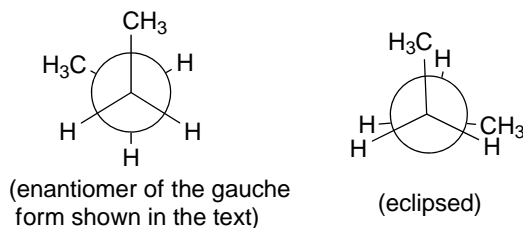

In the eclipsed conformation, the electron pairs in the eclipsed bonds repel each other giving rise to a torsional strain. Therefore its energy is higher than that of the gauche conformations.

3.16

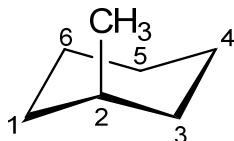

Carbon atom C2 is equidistant from both C4 and C6. Therefore, C4 and C6 have the same relationship to the axial-CH<sub>3</sub> in the 2-position, although it is not clear from the Newman projection.

3.17

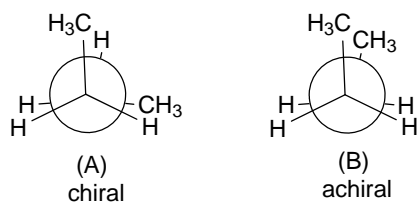

Of the two eclipsed conformers of n-butane, only (A) is chiral (no element of symmetry). (B) is superimposable to its mirror image due to the presence of a plane of symmetry.

3.18

The rapid exchange between mirror images of the gauche conformation of n-butane occurs through the following mechanism:

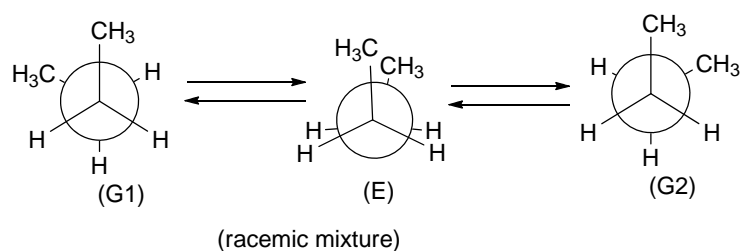

The intermediate (E) which is achiral, is highly unstable. This explains the rapid exchange between (G<sub>1</sub>) and (G<sub>2</sub>)

In the case of the eclipsed forms, the exchange mechanism takes place as follows:

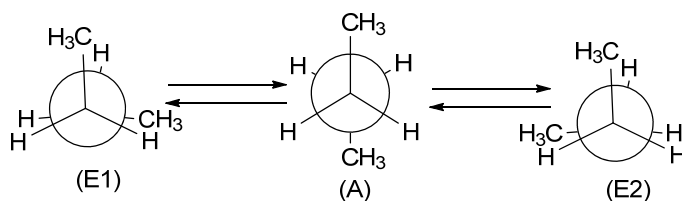

The intermediate (A) which is achiral, exists in a minimal energy state.

3.19

- a) Ring flipping converts all substituents in equatorial positions to axial positions and vice versa. Therefore,  $\alpha$ - and  $\beta$ -D-glucose are not interconvertible

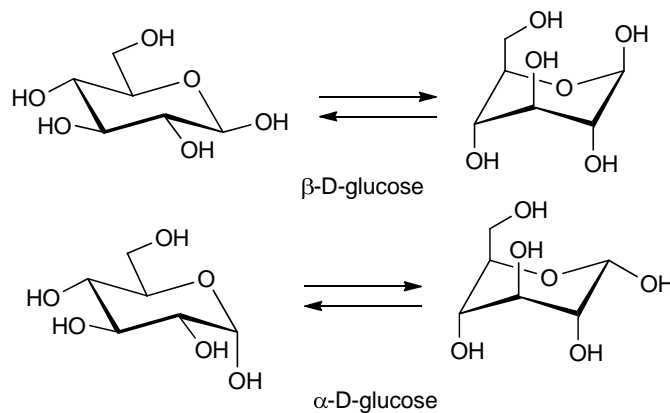

b) Same reason as above

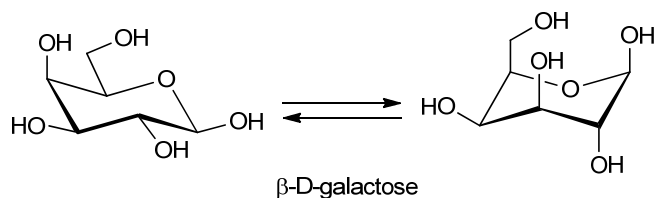

c) The two diastereomers of methylcyclohexane differ only in the CH<sub>3</sub> group orientation, which switches from axial to equatorial, thus interconverting the two isomers.

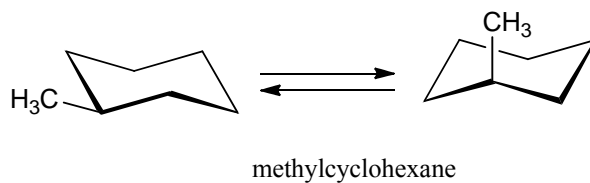

3.20

D-glucose and D-galactose differ only in the configuration of one carbon atom (C4) and torsional motions cannot interconvert them, then they are *configurational diastereomers*. The same answer applies to α- and β-D-glucose.

Torsional motions can interconvert isomers of methylcyclohexane. Therefore, they are *conformational diastereomers*.

3.21

Examples of configurational diastereomers:

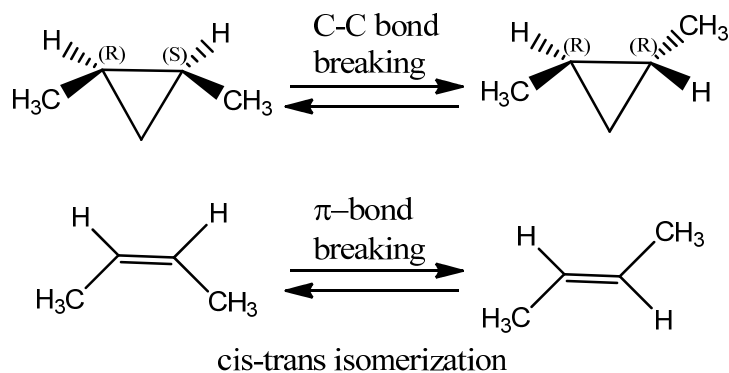

Examples of conformational diastereomers:

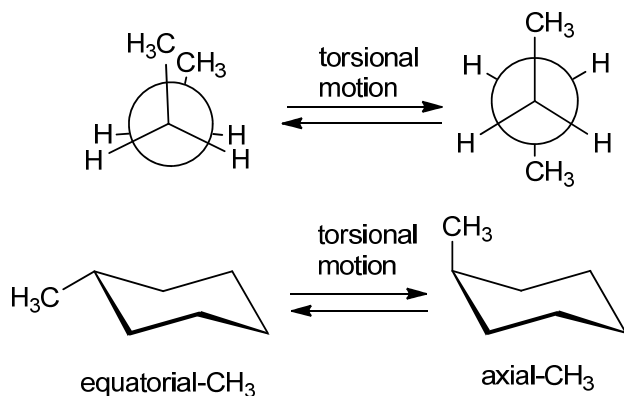

3.22

By applying the strain necessary, one should go through different conformations of cyclohexane ring:

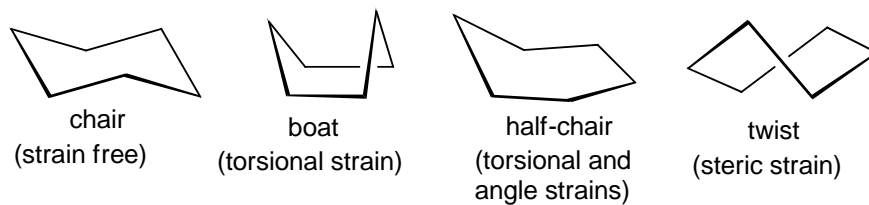

3.23

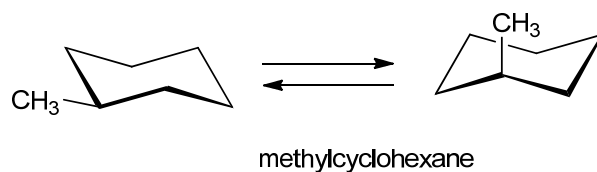

Only one group (CH<sub>3</sub>) switches from equatorial to axial (lower energy barrier).

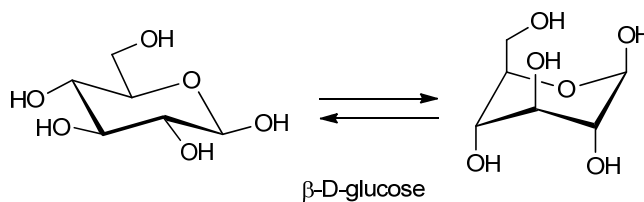

Five groups switch from equatorial to axial. This process requires a higher energy barrier.

3.24

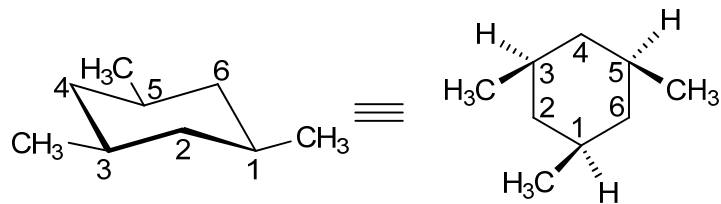

All CH<sub>3</sub> groups are in the cis-conformation, thus pointing in the same direction.

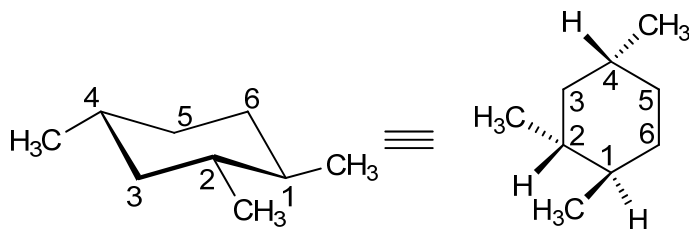

Two of the three are in cis while the third is in trans with others. They are not pointing in the same direction. By switching the CH<sub>3</sub> in the 1-position from equatorial to axial, all CH<sub>3</sub> groups would be in cis.

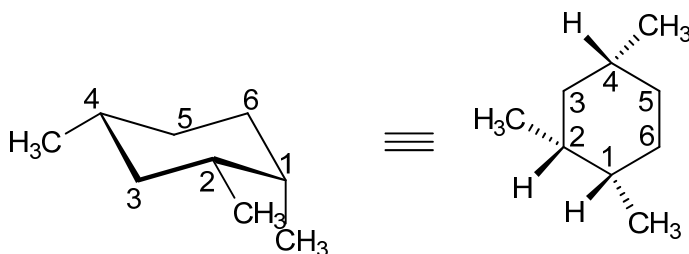

3.25

In the all cis-conformation, flipping of 1,3,5-trimethylcyclohexane ring converts all CH<sub>3</sub> groups from equatorial (the most stable) to axial (the less stable). Whereas, flipping of the 1,2,4-ring converts two CH<sub>3</sub> groups from equatorial to axial and the third from axial to equatorial, thus requiring less of an energy barrier.

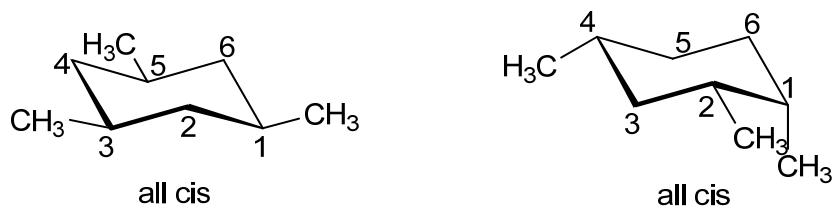



3.26

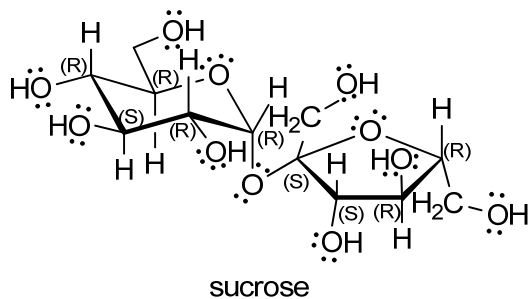

no formal charge

no violation of the octet rule

The (R)/(S) assignments could be made following the CIP rule (see section 1.12 in chapter 1).

3.27

Here are some examples of isomers corresponding to the formula  $C_6H_{12}O_6$ :

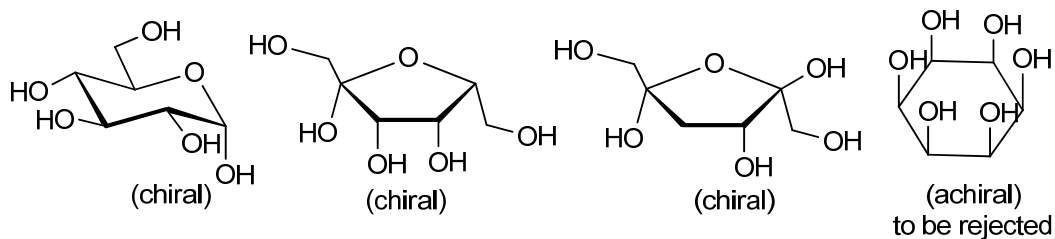

and there are others.

3.28

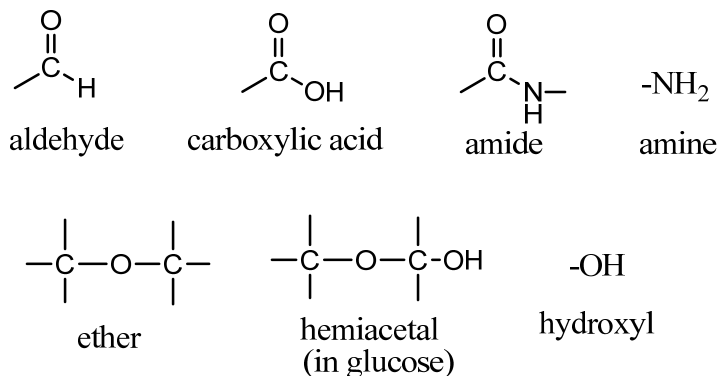

and others...

3.29

When one diastereomer  $\alpha$  or  $\beta$  of D-glucose is dissolved in water, the six-membered ring undergoes opening and closing, a process by which  $\alpha$  or  $\beta$ -glucose interconvert with each other until an equilibrium state is reached: this process is called *mutarotation*.

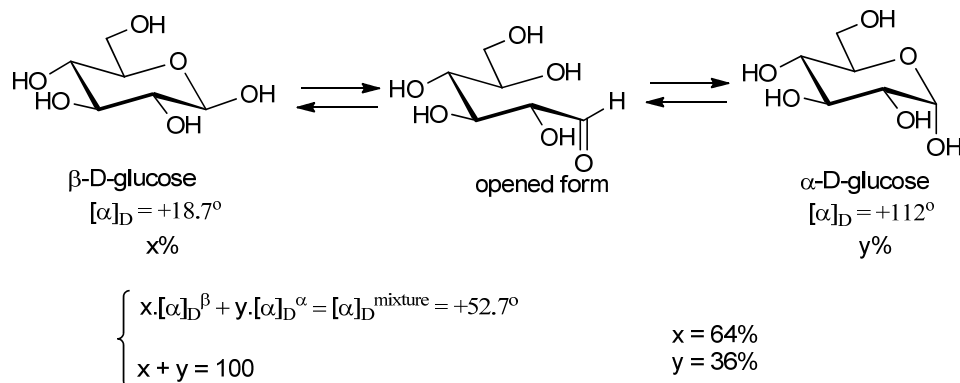

3.30

In the process of mutarotation as shown in answer to problem 3.29, the diastereomeric change takes place through breaking of a C-O bond. This explains why  $\alpha$  and  $\beta$  are *configurational diastereomers*.

3.31

Each cyclic form would exist in two possible configurational diastereomers  $\alpha$  and  $\beta$  as seen in answer to problem 3.29. Therefore, a total of 32 stereoisomers would be possible.

3.32

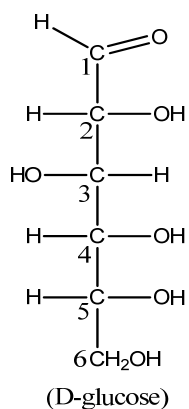

Glucose in the opened form, has four chiral carbon atoms (C2, C3, C4, C5);  $n = 4$ .

The number of possible isomers is:

$$2^n = 2^4 = 16$$

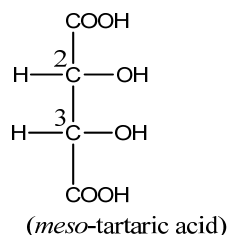

In tartaric acid,  $n = 2$ . However, due to symmetry, C2 and C3 are identical, leading to a *meso* form. Therefore, there are:  $2^n - 1 = 3$  isomers.

3.33

There are 8 diastereomers each present as a pair of enantiomers. Therefore, there are a total of 8 pairs of enantiomers designated (D, L).

3.34

Let do it for D-glucose. The same principle should work for other isomers.

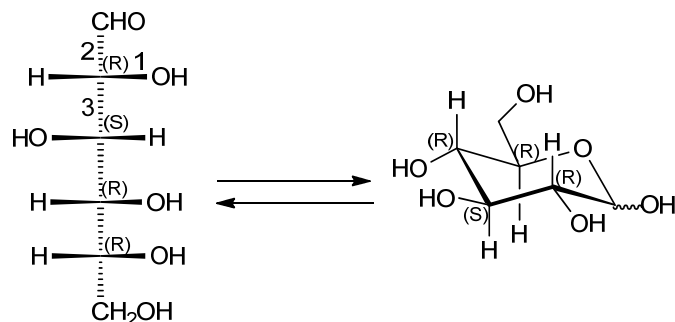

3.35

Because in a Fisher projection, all horizontal bonds project toward the viewer and vertical bonds project away from the viewer, by definition. Therefore, a Fisher projection cannot be rotated by  $90^\circ$  in the plane of the page, as the orientation of bonds relative to one another can change converting a molecule to its enantiomer.

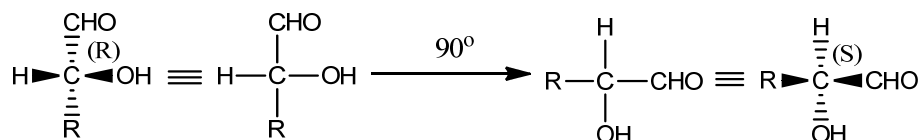

3.36

There are a total of eight pairs of enantiomers. Since enantiomers have identical physical properties such as melting point, only eight parameters would be found experimentally, one for each pair of enantiomers.

3.37

Because glucose's conformation is the most stable since it has all pendant groups in equatorial positions.

This statement is true for either D or L-glucose, therefore, choice of D-isomer over L-isomer remains a mystery.

3.38

The protocol used by Fisher could be found in many places, therefore will not be discussed in details here. The general idea was to take advantage of the differing symmetry properties of the possible stereoisomers.

For example, oxidation of each of the eight D-sugars by nitric acid would give the so-called "aldaric acids" by converting  $-\text{CHO}$  and  $-\text{CH}_2\text{OH}$  groups to  $-\text{COOH}$ . The vials with optically inactive products could only be derived by oxidation of D-allose or D-galactose.

3.39

D-glucose and D-gulose differ only in the absolute configurations of C3 and C4 carbon atoms.

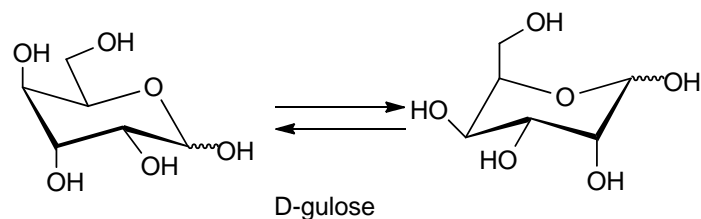

In both flipped conformations, two pendant groups are axial.

3.40

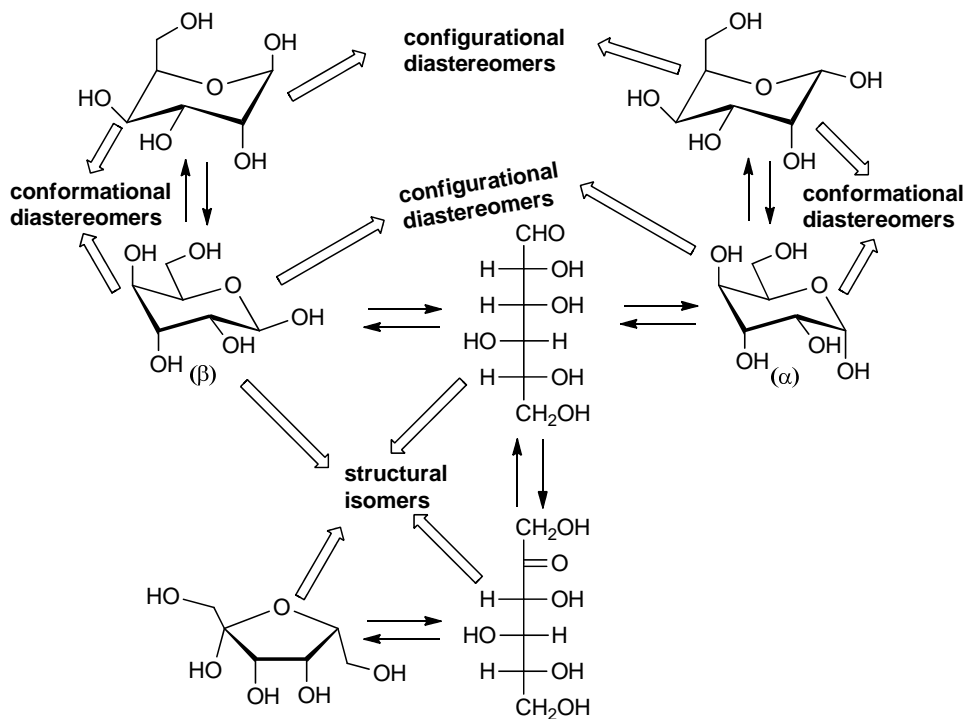

3.41

Ring flipping would increase the stability of a given diastereomer if most pendant groups switch from axial to equatorial during this process.

Idose would benefit most because it has the highest number (3) of axial pendant groups.

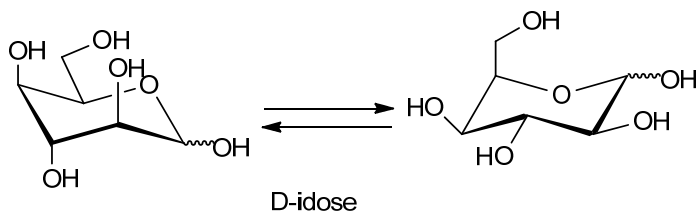

3.42

Yes. Because L-glucose would still have the same stability as D-glucose (all pendant groups in equatorial).

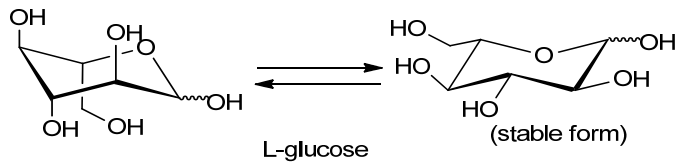

3.43

Mothers' milk (lactose) is a dimer of D-glucose and D-galactose.

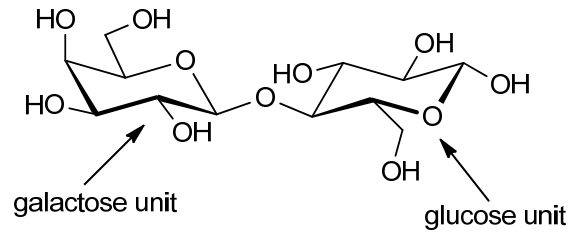

Due to its continuous bioavailability, it would have been better if evolution had constructed mothers' milk entirely from D-glucose.

The advantage of using D-galactose might be found in its ability to form a more favored opened form, which is the starting material for acetal formation (connection between the two sugars).

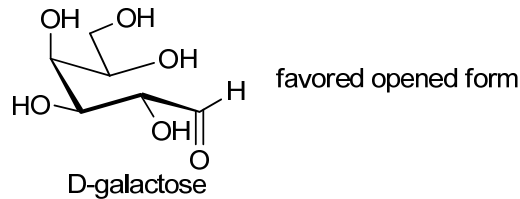

3.44

A ring form of a sugar is more favored than the opened form if the majority of the pendant groups occupy an equatorial position. In some cases, both flipped rings are more unstable than the opened form (e.g. D-gulose)

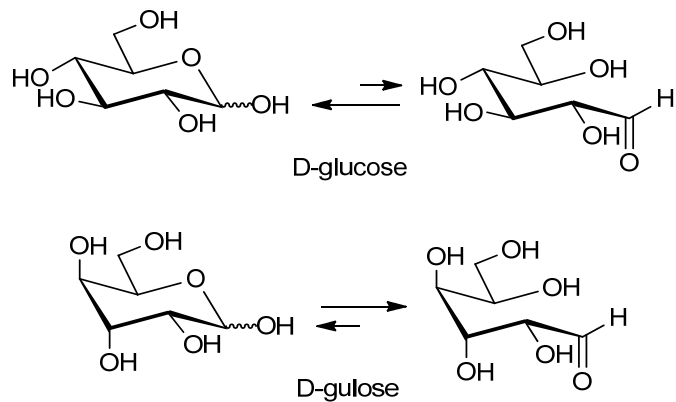

3.45

We will do it for glucose and idose.

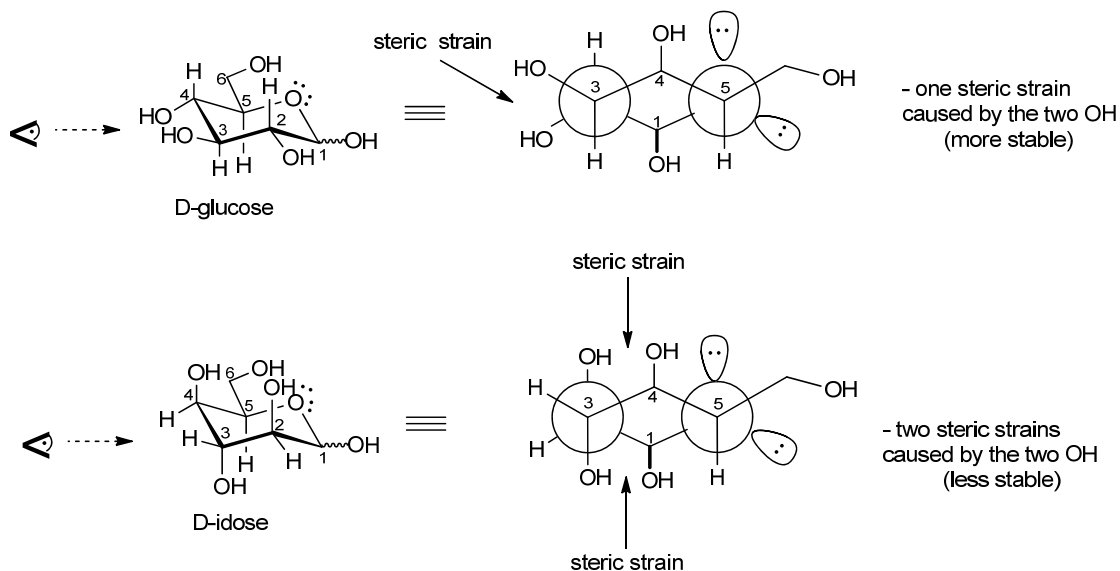

3.46

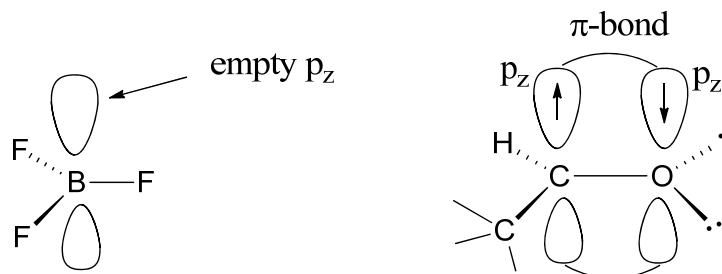

Analogy: both entities are planar ( $sp^2$  hybridization)

Difference:  $\text{BF}_3$  has an empty  $p_z$  orbital, while in aldehyde,  $p_z$  orbitals of the oxygen and the carbon atoms are occupied by one single electron each, which overlap to form a  $\pi$ -bond.

3.47

In  $\text{BF}_3$ ,  $p_z$  is empty and is not included in the hybridized orbitals. Therefore, the molecule exists in the  $(x,y)$  plane.

In aldehyde, the  $p_z$  orbitals are occupied each by one electron. These two orbitals can overlap in a direction parallel to the  $(x,y)$  plane to form the  $\pi$ -bond, allowing therefore the molecule to exist in the  $(x,y)$  plane.

3.48

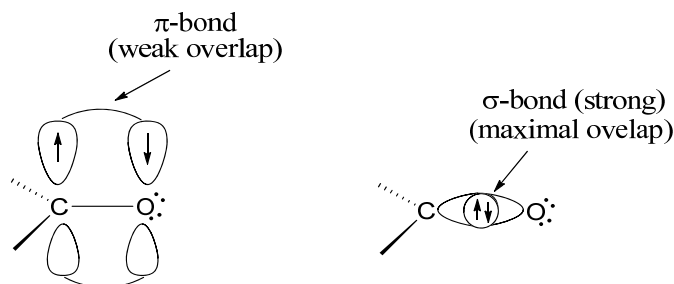

The  $\sigma$ -bond results from overlap between two orbitals along the same axis (strong overlap) whereas, the  $\pi$ -bond is formed in a direction perpendicular to that of the original atomic orbitals  $p_z$  (weak overlap).

### Similarity to ethylene $C_2H_4$

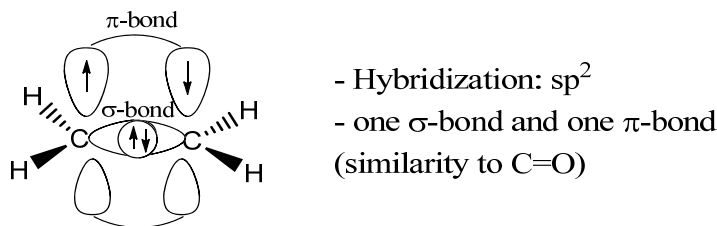

3.49

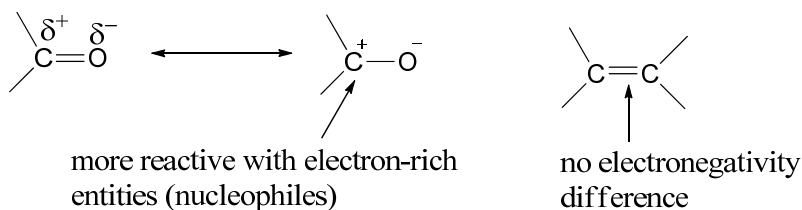

Oxygen has a large electronegativity compared to carbon and would attract the pair of electrons forming the  $\pi$ -bond. This leaves the carbon atom with less electron density.

3.50

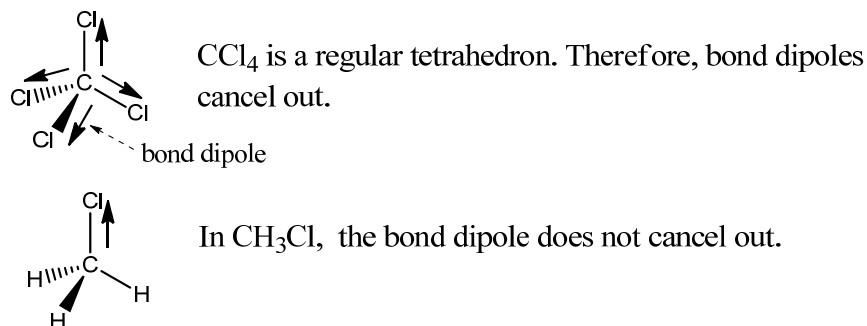

3.51

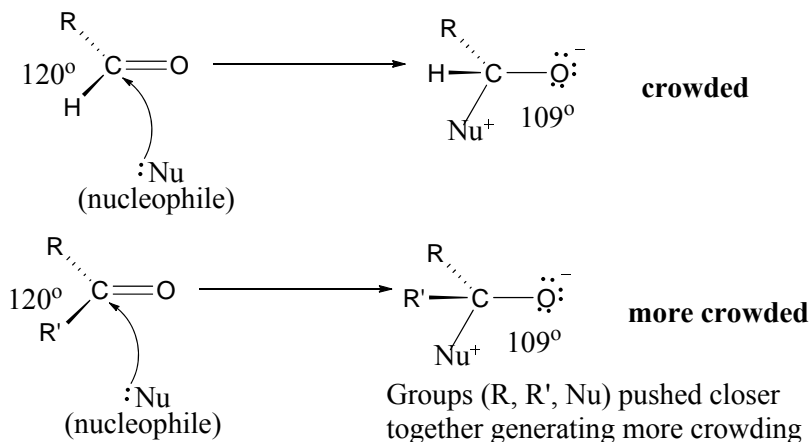

3.52

Because in an alkene such as  $\text{CH}_2=\text{CH}_2$ , there is no electronegativity difference in contrast to the case of a carbonyl group ( $\text{C}=\text{O}$ ), where the electronegativity is the driving force for the reactivity of the carbon atom, which is electrophilic.

3.53

$^{13}\text{Al}: 1s^2 2s^2 2p^6 3s^2 3p^1$

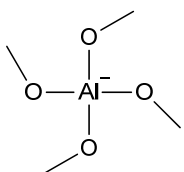

**Accounting:** 1 electron from each bond = 4  
 10 internal electrons (1s, 2s, 2p) = 10  
 Total = 14

The atomic number (number of positive charges) is 13. Therefore, there is one negative charge on Al

$^{14}\text{Si}: 1s^2 2s^2 2p^6 3s^2 3p^2$

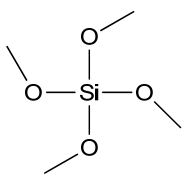

**Accounting:** 1 electron from each bond = 4  
 10 internal electrons (1s, 2s, 2p) = 10  
 Total = 14

The atomic number (number of positive charges) is 14. Therefore, there is no formal charge.

3.54

The intermediates have the structures similar to that reported in answer to problem 3.51 for aldehyde ( $\text{Nu} = -\text{OH}$  or  $-\text{NH}_2$ ).

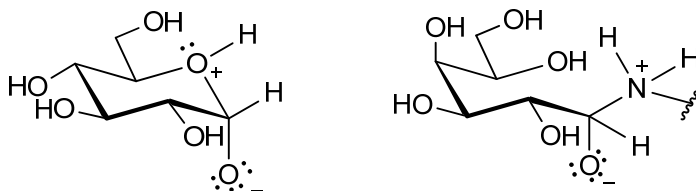



3.55

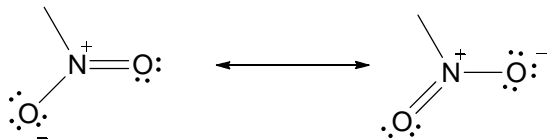

There is no structure possible in the nitro functional group without a charge separation, that is, without a formal charge.

Charge separation is a destabilizing effect and might be the source of connection between formal charge and explosive power for nitro groups.

3.56

The region around  $1700\text{ cm}^{-1}$  corresponds to  $\text{C}=\text{O}$  stretching frequency. In glucose, this band is almost absent because the ring conformation is the most favored, while galactose which has a significant proportion of opened form, would give a stronger band in the  $1700\text{ cm}^{-1}$  region.

3.57

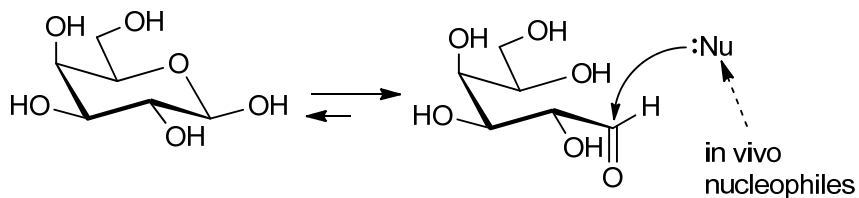

## Chapter 4

4.1

See answer to problem 3.53.

4.2

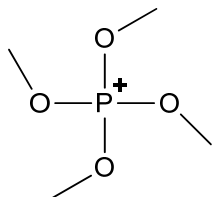
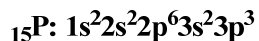

**Accounting:** 1 electron from each bond = 4  
 10 internal electrons (1s, 2s, 2p) = 10  
 Total = 14

The atomic number (number of positive charges) is 15. Therefore, the formal charge is +1.

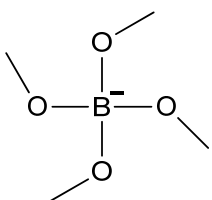
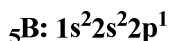

**Accounting:** 1 electron from each bond = 4  
 2 internal electrons (1s) = 2  
 Total = 6

The atomic number (number of positive charges) is 5. Therefore, the formal charge is -1.

4.3

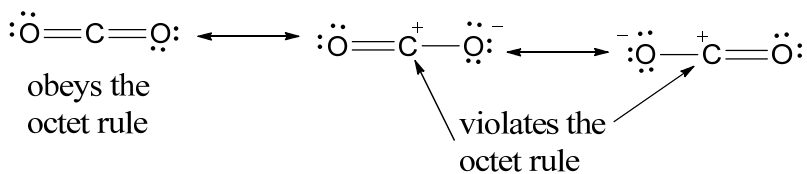
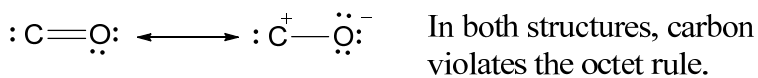

4.4

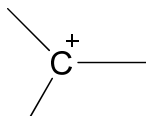

There are three covalent bonds surrounding a carbocation, accounting for a total of six electrons, therefore the number of bonding electrons belonging to carbocation is three. Of the

four protons in the nucleus available for the valence electrons in a carbon atom, only three compensate the three bonding electrons, leading to a positive charge.

This positive charge and the formal charge are the same. Furthermore, carbocations do not obey the octet rule.

4.5

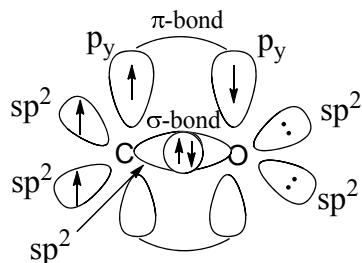

#### Aldehyde carbon

- three  $sp^2$  orbitals
- one  $p_y$  orbital with one electron which overlaps with  $p_y$  of O to give the  $\pi$ -bond.
- planar geometry

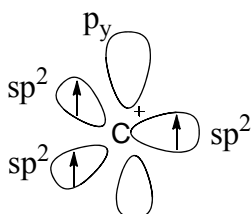

#### Carbocation

- three  $sp^2$  orbitals
- one  $p_y$  orbital (empty)
- planar geometry

The aldehyde group carbon atom and the carbocation have the same type of hybridization ( $sp^2$ ), then the same geometry (planar), but differ on the character of  $p_y$  orbitals.

4.6

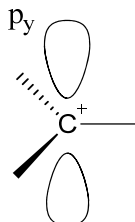

In a carbocation, the  $p_y$  orbital is empty and is left out of the hybridization. Therefore, the carbocation exists in the  $xz$  plane ( $sp^2$  hybridization).

4.7

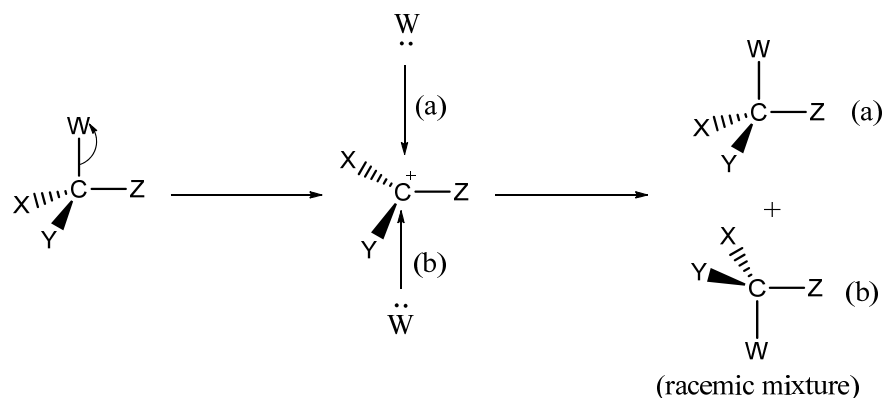

The intermediate carbocation is planar, allowing the lost group(W) to attack at both faces, therefore yielding racemization.

4.8

Isoborneol (alcohol) and camphene (alkene) have different formulas. Therefore, they are not isomers.

Tetrahydrodicyclopentadiene and adamantane are *structural isomers* (same formula but different connections through atoms).

4.9

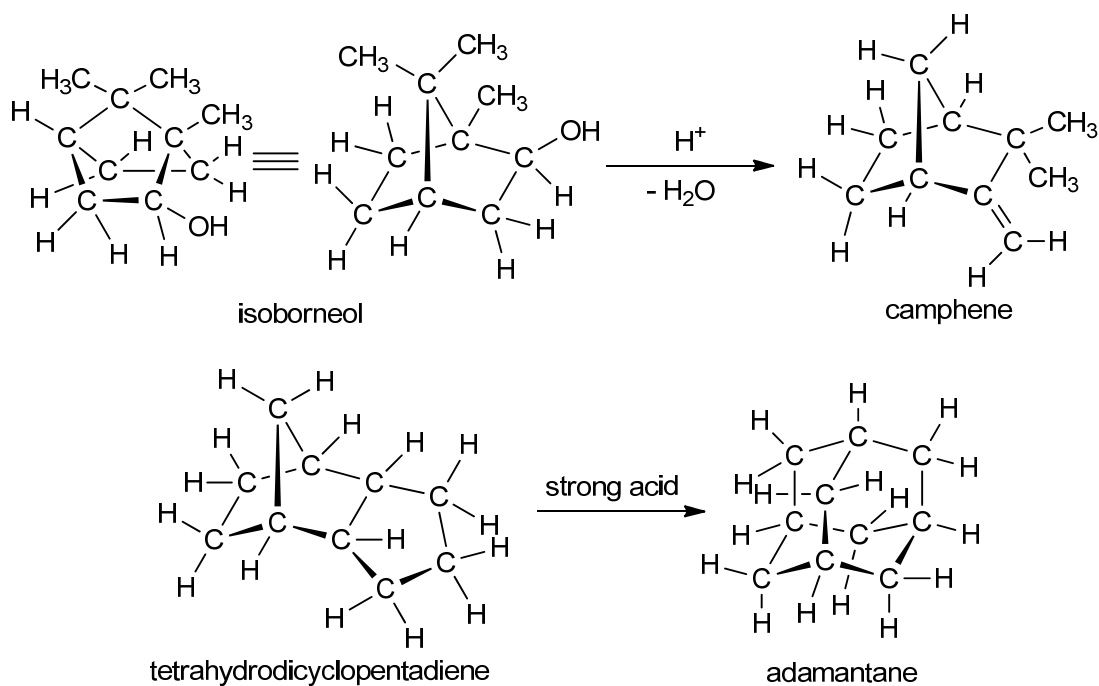

Removal of one molecule of water from isoborneol gives the following compound, which is a *structural isomer* of camphene:

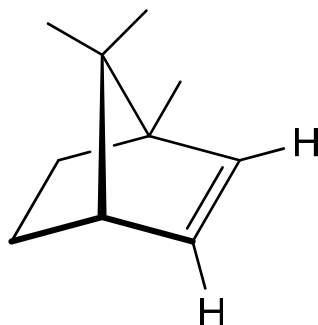

4.10

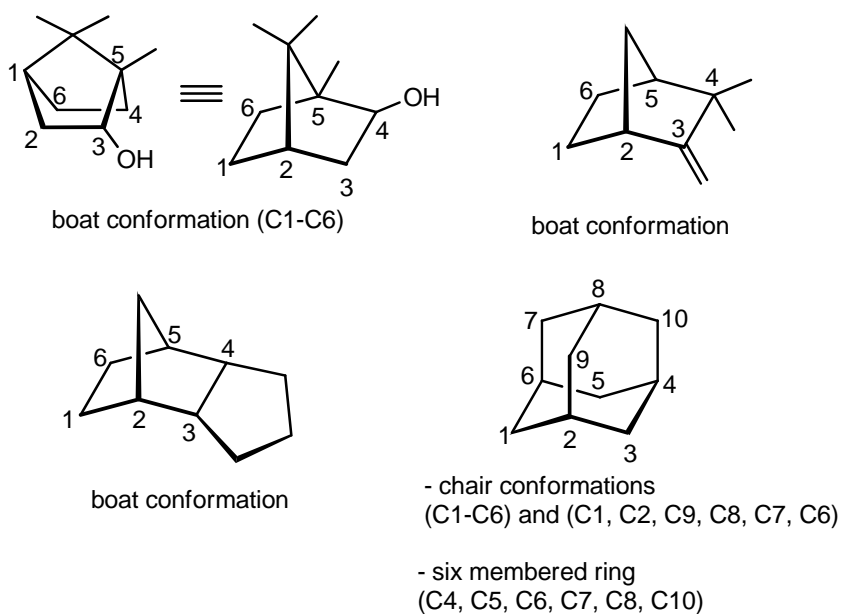

The boat conformations suffer torsional strains.

4.11

Yes. Adamantane

4.12

Not within the rings. However, all the CH<sub>3</sub> groups can undergo conformational motion and also the OH group.

4.13

-OH  
hydroxyl

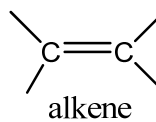

4.14

The only atom in the first row of the periodic table, in organic structures is hydrogen, which obeys the equivalent of the octet rule. It combines with other atoms in such a way that each H atom has two electrons in its valence shell, giving the same electron configuration as  ${}^2\text{He}$  (2 valence electrons).

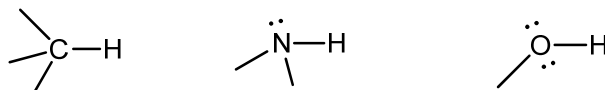

4.15

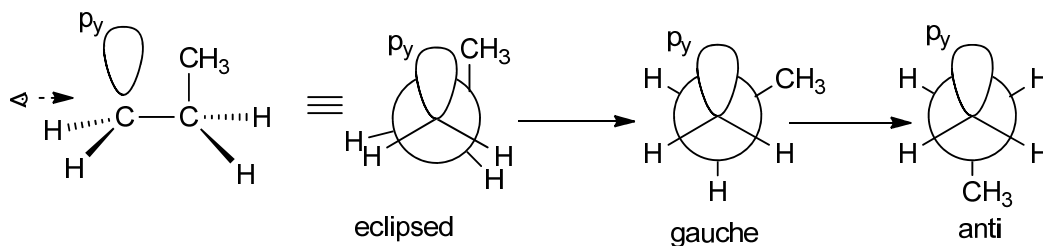

4.16

The eclipsed conformation will suffer torsional strain not present in the gauche and anti conformations.

4.17

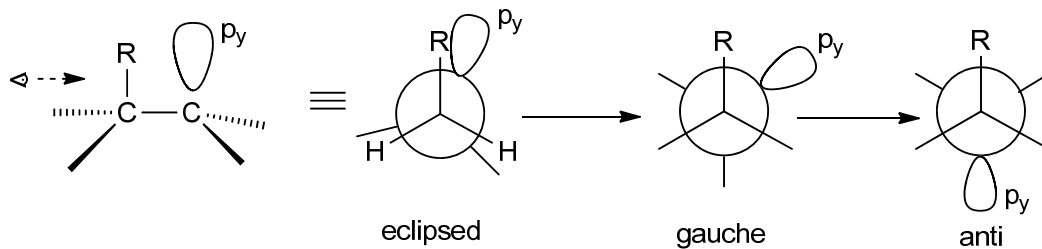

In the eclipsed form, R and  $p_y$  are in a favorable position to allow the 1,2-shift of the R groups, which is unlikely in the anti or the gauche orientation.

4.18

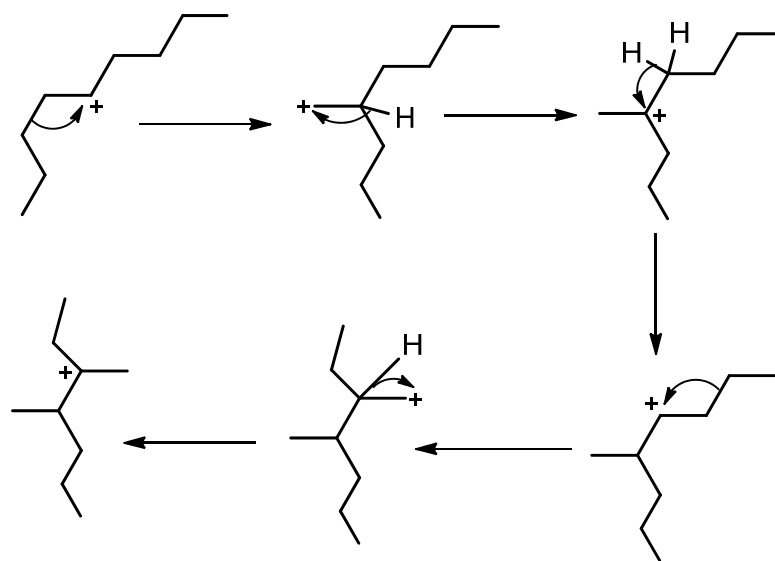

Yes. More branched structures for  $C_9H_{20}$  could be:



4.19

We will draw n-nonane and a few branched structures of formula  $C_9H_{20}$

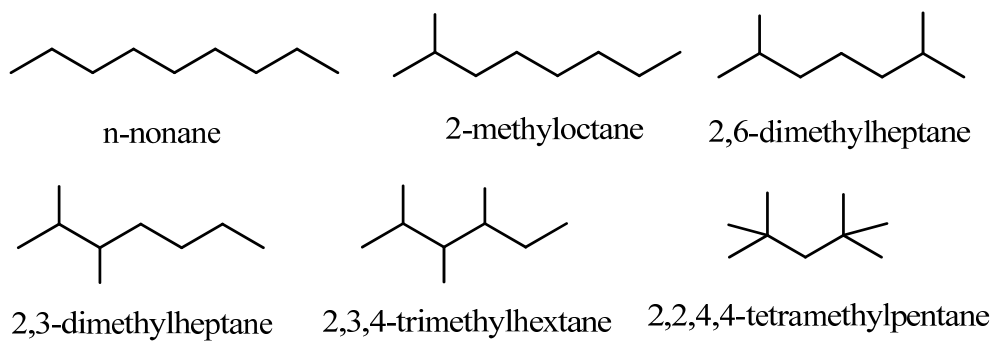

The isomers with the highest “octane number” should be the most branched ones. Therefore, 2,2,4,4-tetramethylpentane has the highest “octane number” and n-nonane (linear), the lowest “octane number”.

4.20

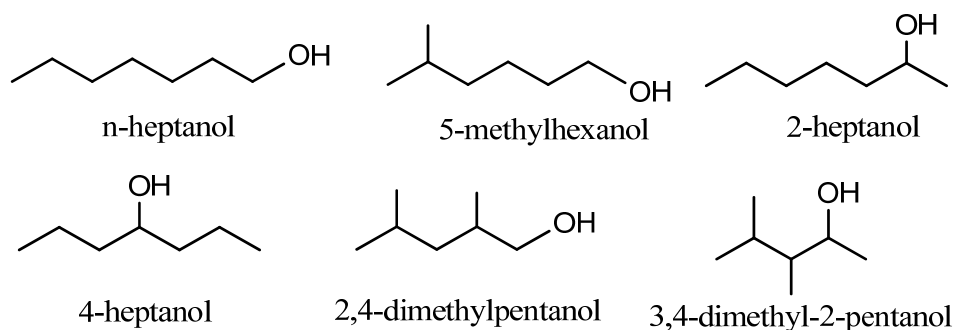

Highest "octane number": 3,4-dimethyl-2-pentanol

Lowest "octane number": n-heptanol

4.21

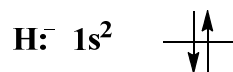

H<sup>-</sup> has two electrons in 1s orbital and acquires therefore the electron configuration of the nearest noble gas (He).

4.22

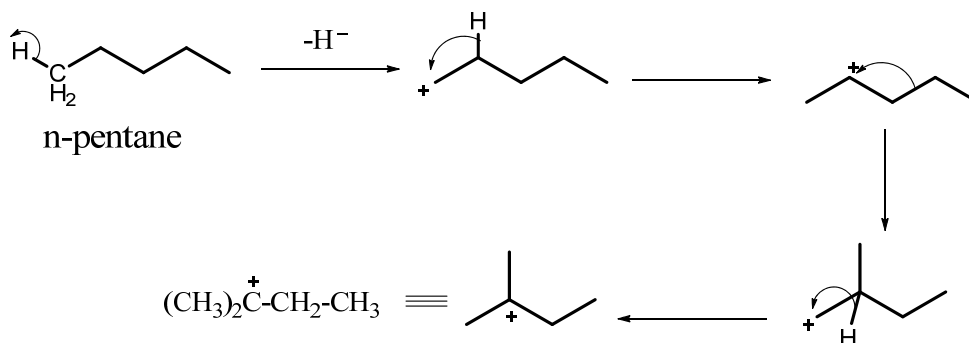

4.23

Let do it for a terminal carbocation in n-octane



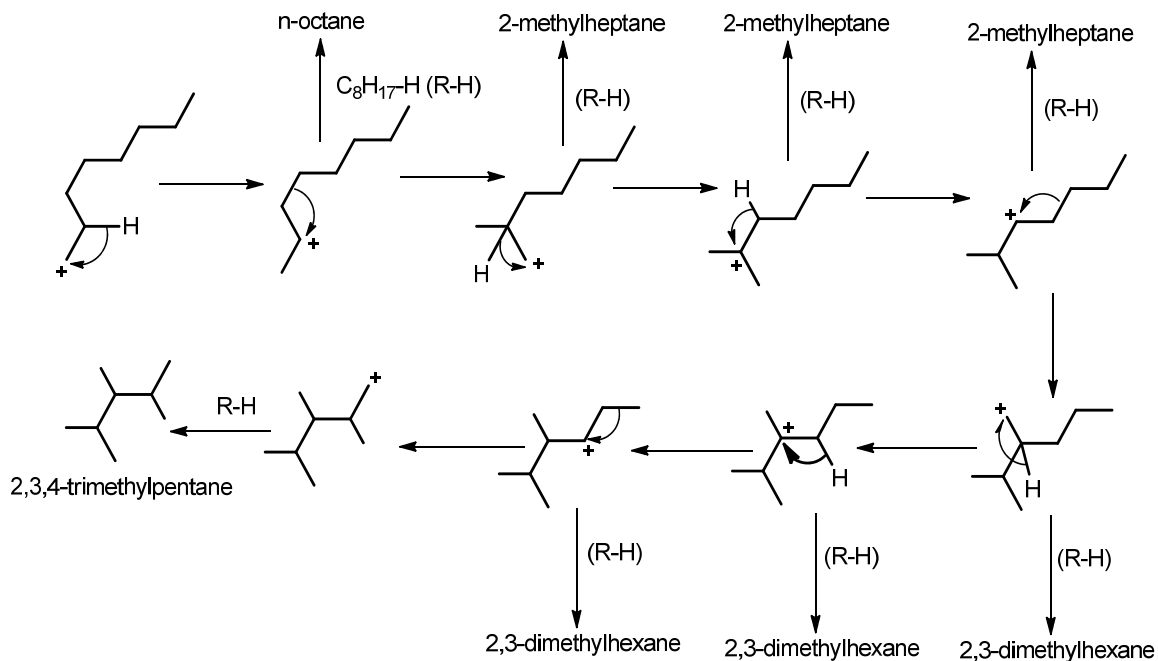

#### 4.24

The intramolecular 1,2-shift moves the positive charge from one position to another within the same molecule, while the intermolecular shift transfers the charge from one molecule to another. The two processes would greatly differ in the entropy change since one involves one molecule and the other two molecules (see section 9.5 in chapter 9).

#### 4.25

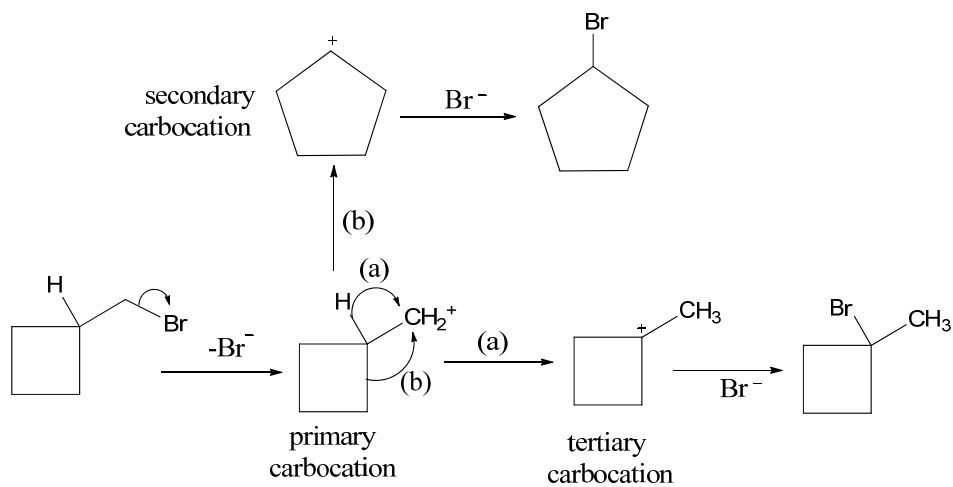

Loss of  $\text{Br}^-$  leads to a primary carbocation (less stable), which can undergo 1,2-shift of  $\text{H}^-$  to give a tertiary carbocation (more stable) or a 1,2-shift of a bond of the 4-membered ring leading to cyclopentyl cation (less strained).

4.26

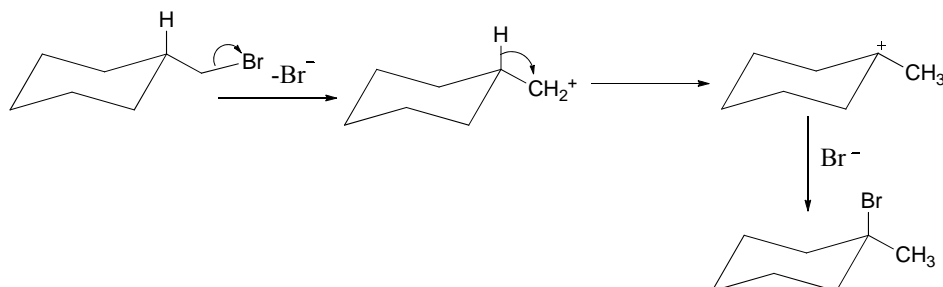

The opening of the ring is less likely because of the lack of strain in the six membered ring.

4.27

1)

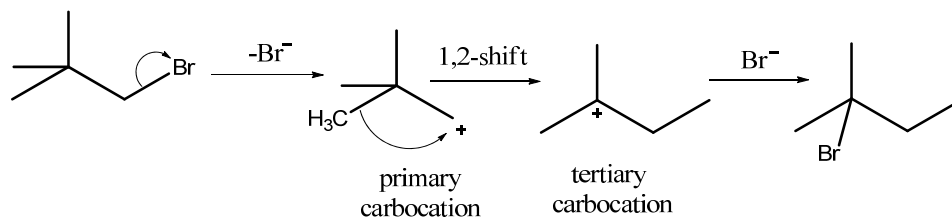

Loss of  $\text{Br}^-$  leads to a primary carbocation (unstable), which undergoes 1,2-shift of a  $\text{CH}_3$  group to give the more stable (tertiary) carbocation.

2)

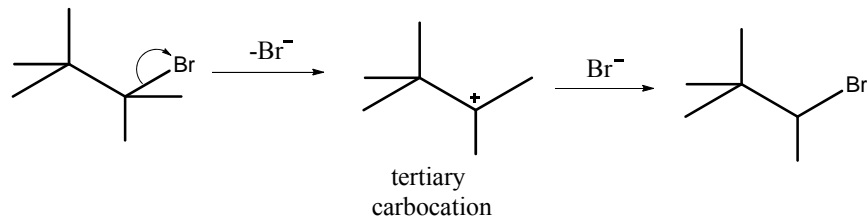

Loss of  $\text{Br}^-$  leads to a tertiary carbocation. Shift of a  $\text{CH}_3$  group would lead to the same carbocation. Therefore, the final and the starting molecules are identical. Rearrangement would not be detected.

4.28

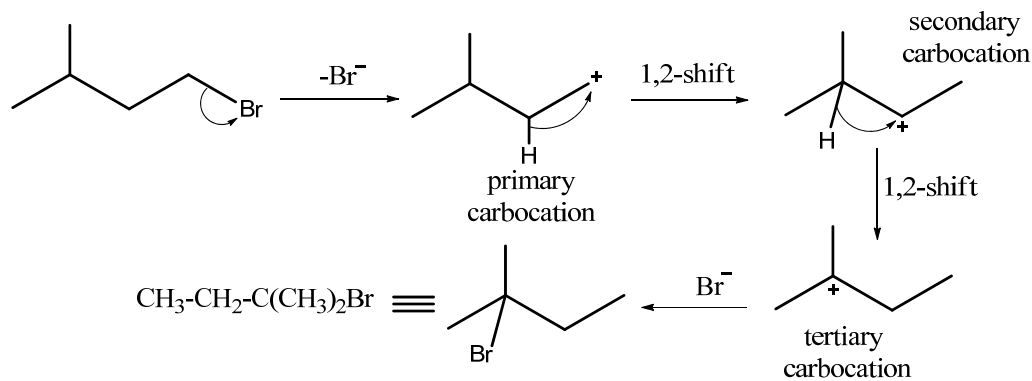

The data in Fig.4.9 show that tertiary carbocation is the most stable, followed by the secondary, then by the primary one. This explains the formation of the more branched bromide.

The roles of 1,2-shifts are to convert the less stable (primary) carbocation to the most stable (tertiary) one. All 1,2-shifts, in this case, involve only hydrogen atoms.

4.29

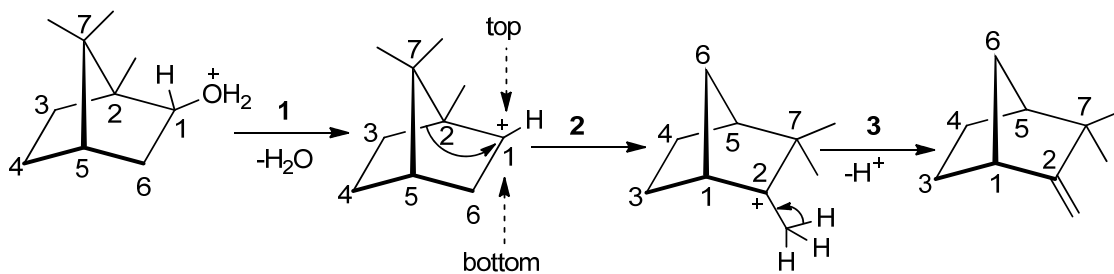

4.30

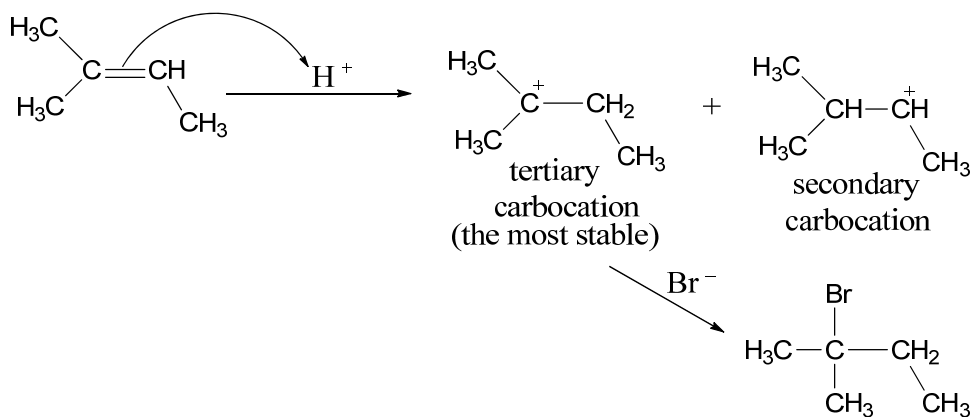

The addition of an electrophile ( $\text{H}^+$ ) to an alkene leads to the most stable carbocation (tertiary in this case).

4.31

<b>Diesel fuel</b>	<b>Gasoline</b>
- linear hydrocarbons (low octane number)	- branched hydrocarbons (high octane number)
- requires a compressive force to ignite the fuel (high compression ratio)	- requires a spark (low compression ratio)
- no pre-ignition problem	- pre-ignition when low octane number hydrocarbons are present
- no knocking problem	- knocking due to internal combustion
- lack of tetraethyl lead (C <sub>2</sub> H <sub>5</sub> ) <sub>4</sub> Pb	- contains (C <sub>2</sub> H <sub>5</sub> ) <sub>4</sub> Pb to reduce knocking which is ignition from the kind of compression occurring in a Diesel engine
- less energy is required to break C-H bonds (fewer CH <sub>3</sub> groups)	- requires higher energy to break C-H bonds in CH <sub>3</sub> groups, therefore spark is necessary

4.32

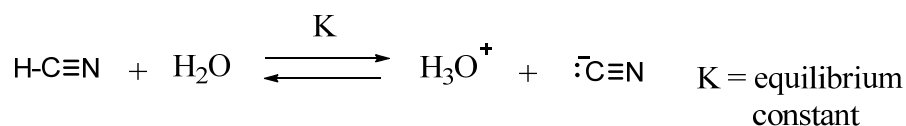

$$K[\text{H}_2\text{O}] = \frac{[\text{H}_3\text{O}^+][\text{CN}^-]}{[\text{HCN}]} = K_a = 10^{-9}; \text{pH} = +9; [\text{H}_2\text{O}] = 56 \text{ M (1L H}_2\text{O} = 1000\text{g}/18 = 55.55 \text{ mol)}$$

$$K = \frac{10^{-9}}{56} = 1.8 \cdot 10^{-11}$$

$K \ll 1$ , therefore, HCN is a weak acid in water.

4.33

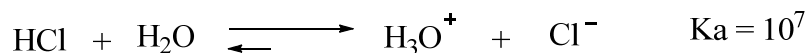

$\text{p}K_a(\text{HCl}) = -7 < 0 < \text{p}K_a(\text{CH}_3\text{COOH}) = 4.8$ .  
HCl is a strong acid while CH<sub>3</sub>COOH is a weak acid.

4.34

Yes. Because the weaker the base, the stronger must be the acid to be able to donate a proton to this base. Therefore, the strength of an acid depends on the base it reacts with. For example, hydrochloric acid is a stronger acid in ammonia than in water.

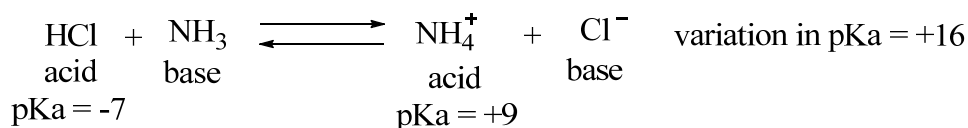
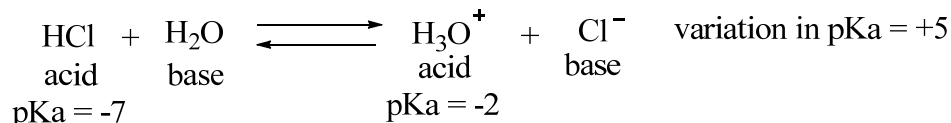

pKa values are solvent dependent and the values reported here refer to aqueous solutions only.

4.35

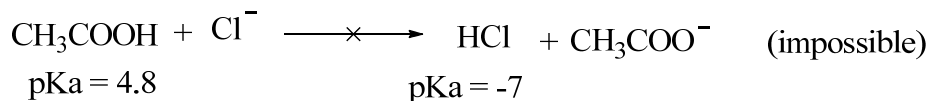
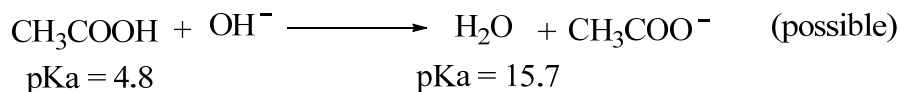

Every acid would be able to donate a proton only to conjugate bases of acids with higher pKa values.

4.36

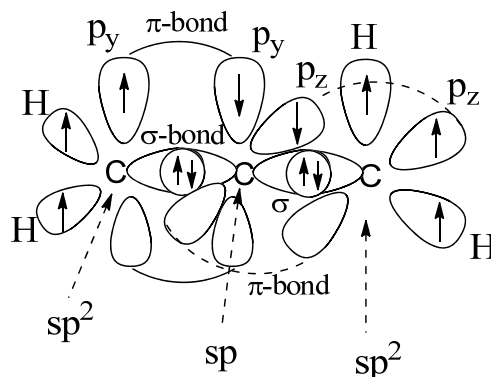

The left-half of the molecule is in the (x,z) plane, while the right-half is in the (x,y) plane. Therefore, the two double bonds of an allene belong to two perpendicular planes.

4.37

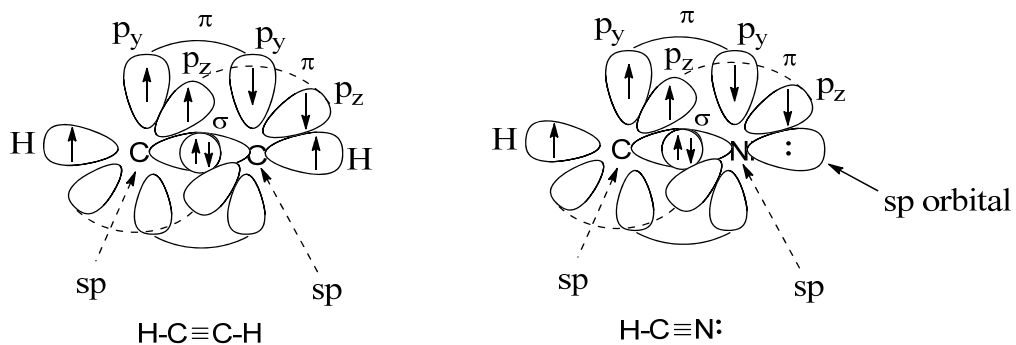

- hybridization:  $sp$
- geometry: linear

4.38

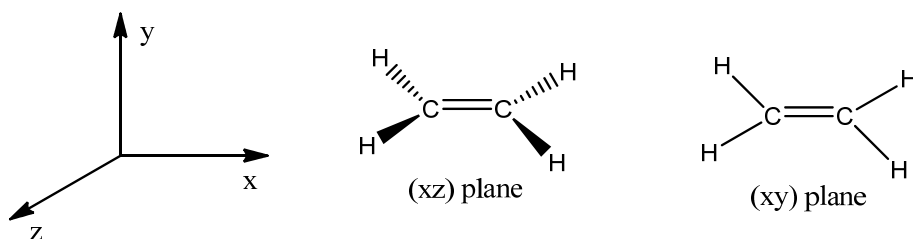

4.39

The reactivity of aldehydes arises from the weakness of the  $\pi$ -bond in combination with the electronegativity difference. In the case of alkenes, although there is no electronegativity difference effect, the  $\text{C}=\text{C}$  bond can easily form a dipole when brought in proximity to an electrophile (electron deficient entity), therefore causing the breaking of the  $\pi$ -bond.

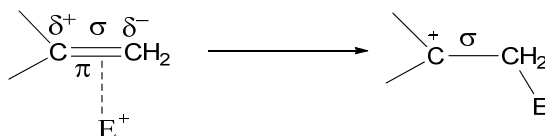

The pair of electrons forming the  $\pi$ -bond is attracted by the electrophile (dipole induction)

4.40

According to Markovnikov's rule, in the addition of an entity ( $\text{HX}$ ) to an asymmetric alkene, the electrophile ( $\text{H}^+$ ) would bind the less branched double bonded carbon atom, therefore leading to the most stable carbocation.

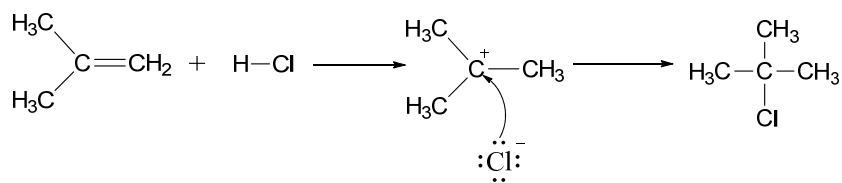

Addition Markovnikov  
(non symmetric alkenes)

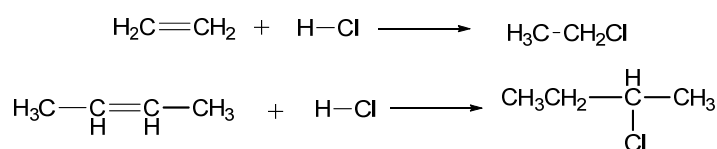

In symmetric alkenes, addition of HCl would not reveal if the addition follows Markovnikov's rule.

4.41

**Step 1**

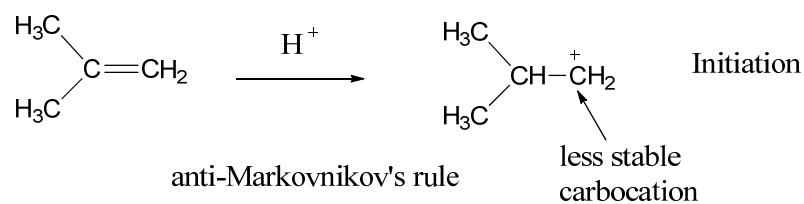

**Step 2**

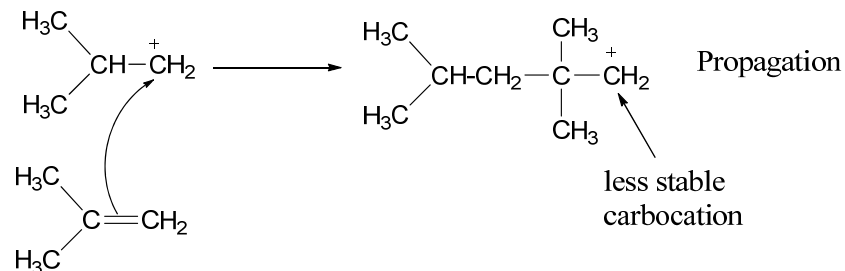

**Step 3**

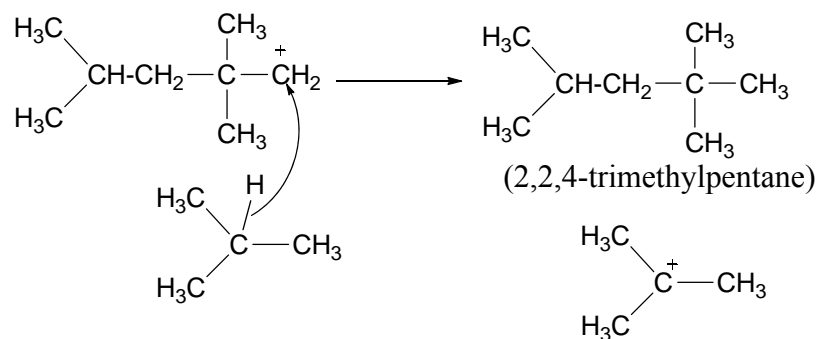

4.42

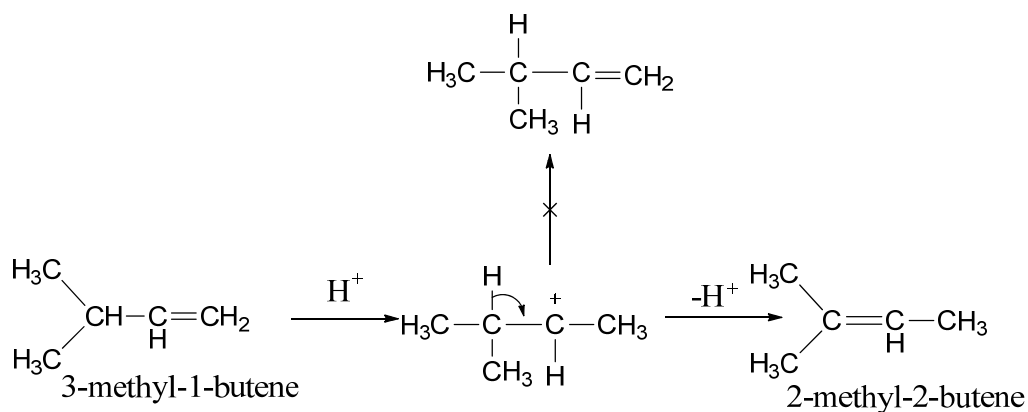

The Markovnikov's rule allows the formation of the more stable (secondary) carbocation. Subsequent loss of a proton from the adjacent more substituted carbon atom leads to a more substituted alkene (thermodynamically favorable).

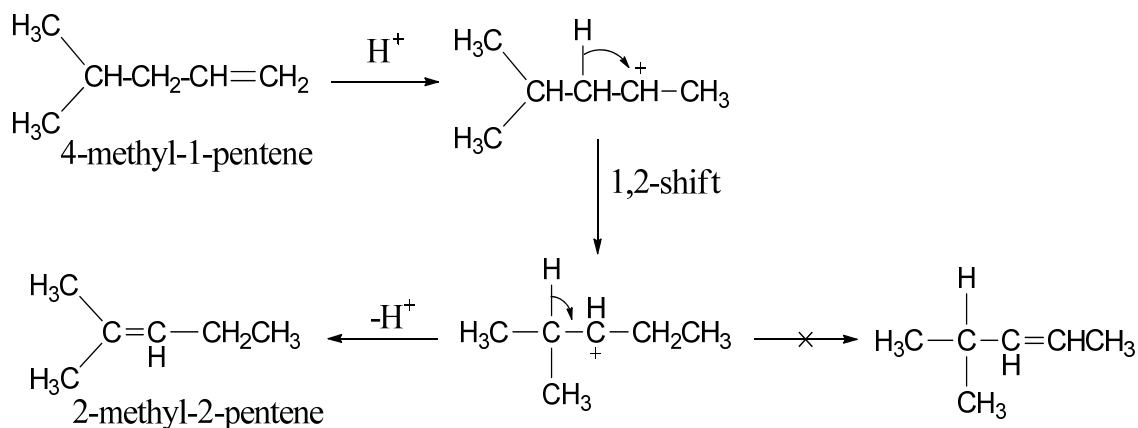

The higher the substitution around the double bond, the higher would be the stability. Therefore, substituted alkenes are more stable than terminal alkenes.

4.43

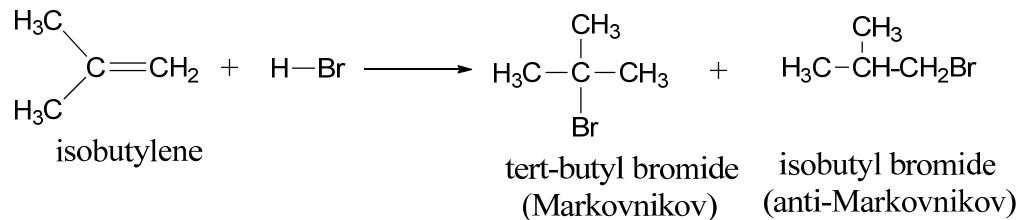



Free radical mechanism:

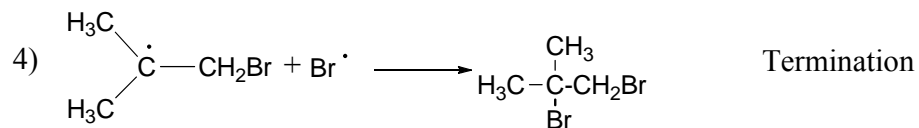
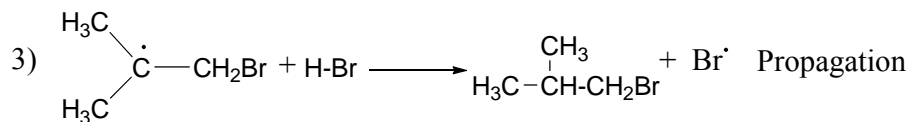
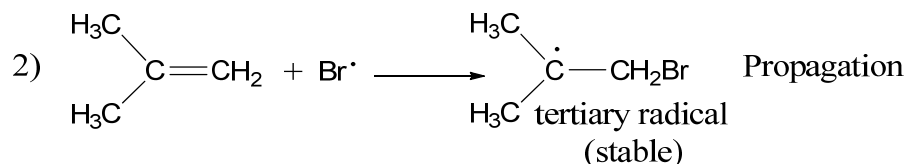

4.44

- True. According to either Lewis's concept (receipt of an electron) or Brønsted-Lowry's concept (loss of a proton).
- True. HCl has no empty orbital to accommodate a lone pair of electrons, it is a Brønsted-Lowry acid.
- False.  $\text{H}^+$  has an empty s orbital and can therefore share a pair of electrons with a donor base.
- True.
- True. HBr is able to donate a proton to a host base
- False. pKa values is related to the strength of an acid and has nothing to do with the basicity of a given molecule. However, the conjugate base of an acid with a large pKa is a strong base, e.g.  $:\text{CH}_3^-$ .
- True. The smaller is the pKa of an acid, the weaker will be the conjugate base.
- True. A negative number for strong acids and a large positive number for very weak acids.
- True. It can share a pair of  $\pi$ -electrons with a given Lewis acid to give a carbocation.
- False. Because the transformations of hydrocarbons in zeolite cavities proceed through carbocations formation (carbocations are Lewis acids).
- False. They are stable, which accounts for the low pKa of the acid from which they are formed.
- False.  $K = \frac{[\text{A}^-]}{[\text{HA}]} = \frac{10^{-\text{pKa}}}{[\text{H}_3\text{O}^+]}$ ,  $\text{pKa} < 0$  corresponds to high K values.
- True.  $\text{pKa}(\text{weaker acid}) > \text{pKa}(\text{stronger acid})$ .

4.45

Fig. 4.13

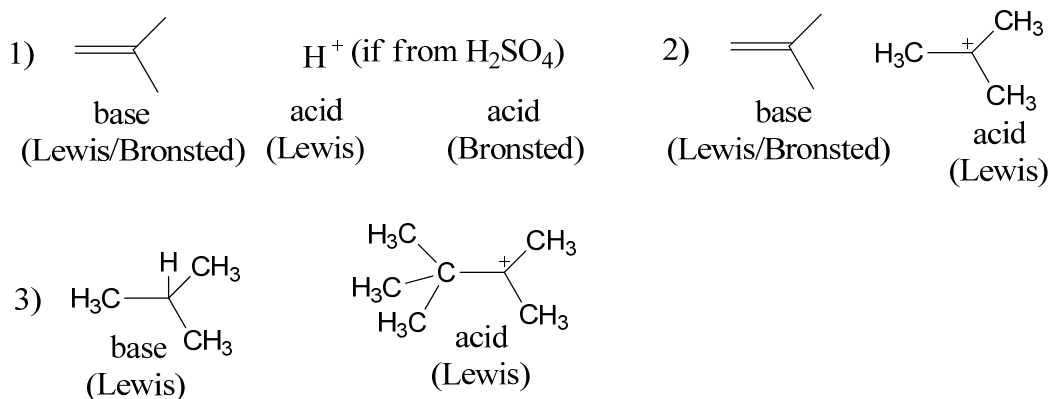
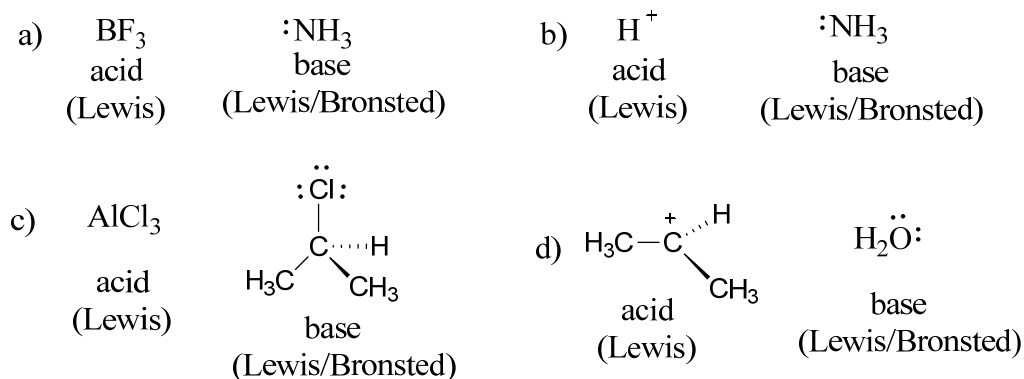
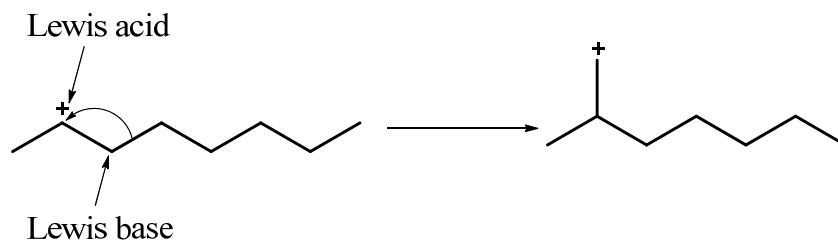

Fig. 4.14



4.46

Yes. The carbocation is the acid (Lewis acid) and the carbon next to the carbocation, which is the source of the pair of electrons donated to the carbocation, is the base.



4.47

Here are some examples in which multiple representations are reasonable.

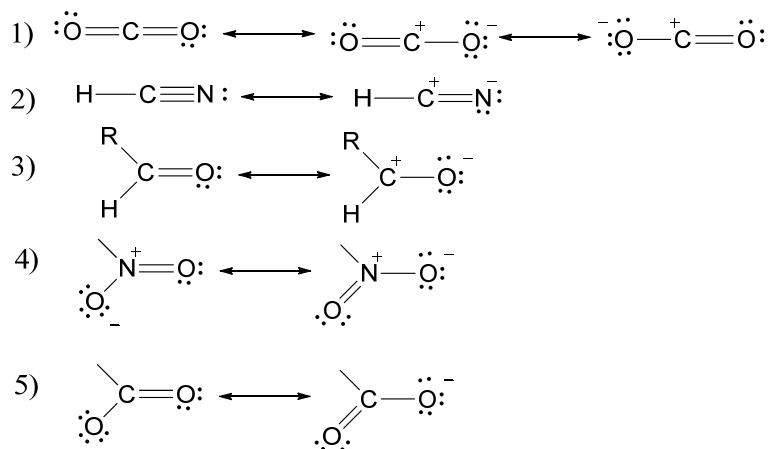

Some molecules where only one representation is reasonable are reported below.

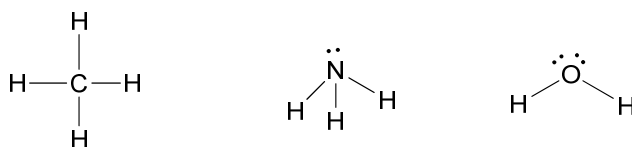

4.48

Yes. Because the positive charge is not concentrated to the tertiary carbon atom. Part of it is distributed between the three equivalent  $\text{CH}_3$  groups.

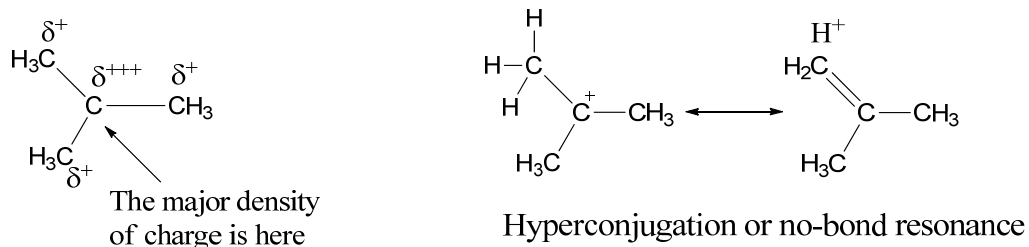

4.49

No. Because benzene has to be described by necessary resonance structures, by moving the  $\pi$ -electrons in different positions keeping the atoms unchanged.

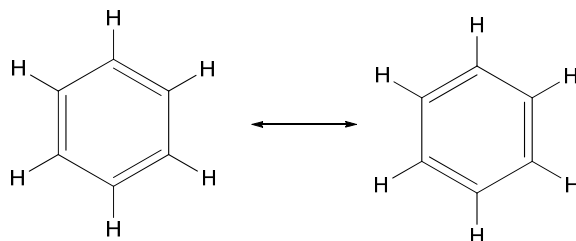

The true structure is a hybrid of the resonance structures shown above and could be represented as follows:

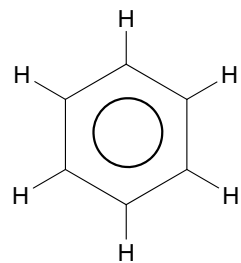

## Chapter 5

### 5.1

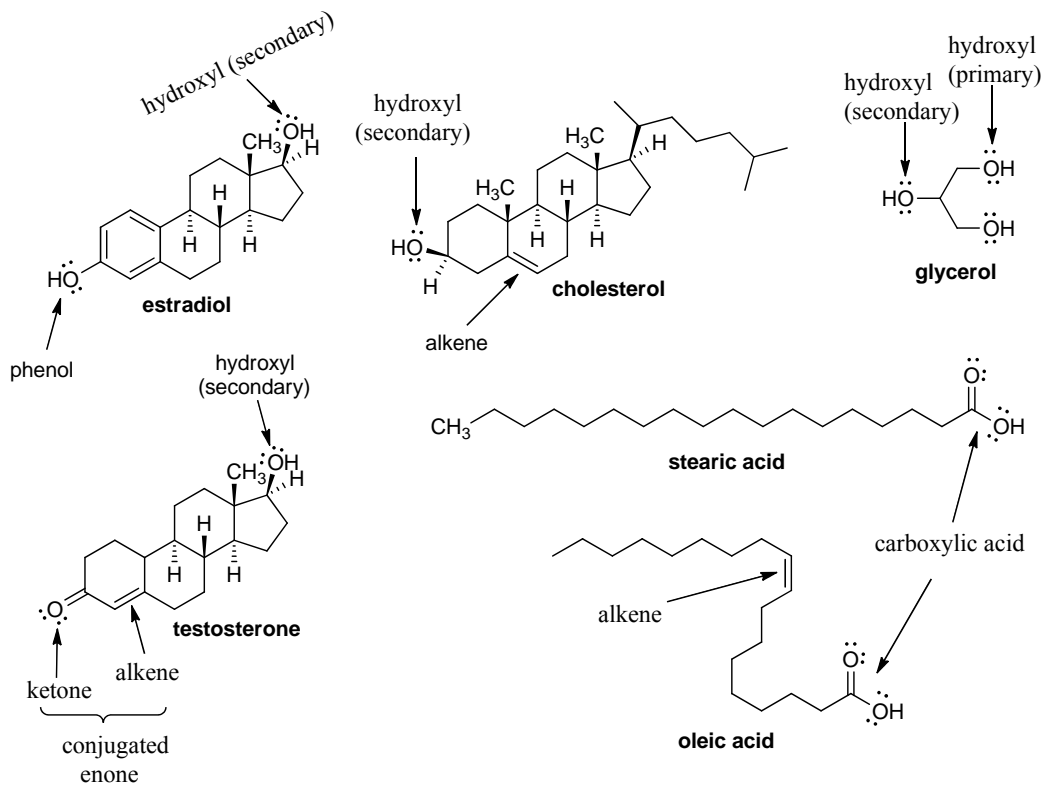

- No formal charge
- No violation of the octet rule

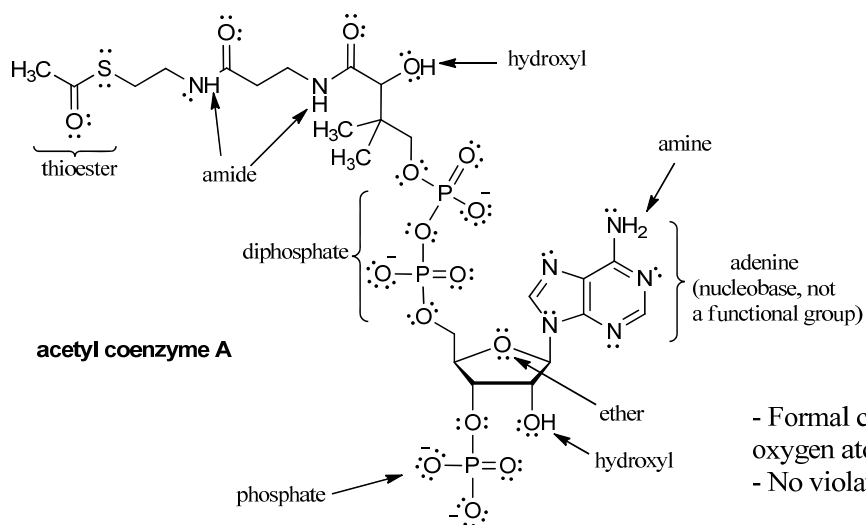

- Formal charge of -1 for some oxygen atoms in phosphate groups
- No violation of the octet rule

5.2

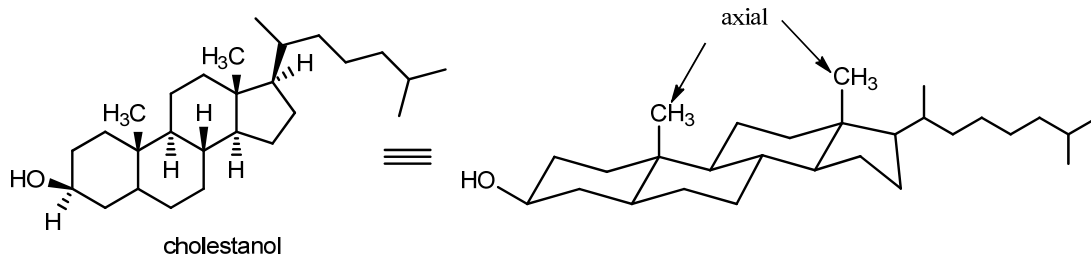

5.3

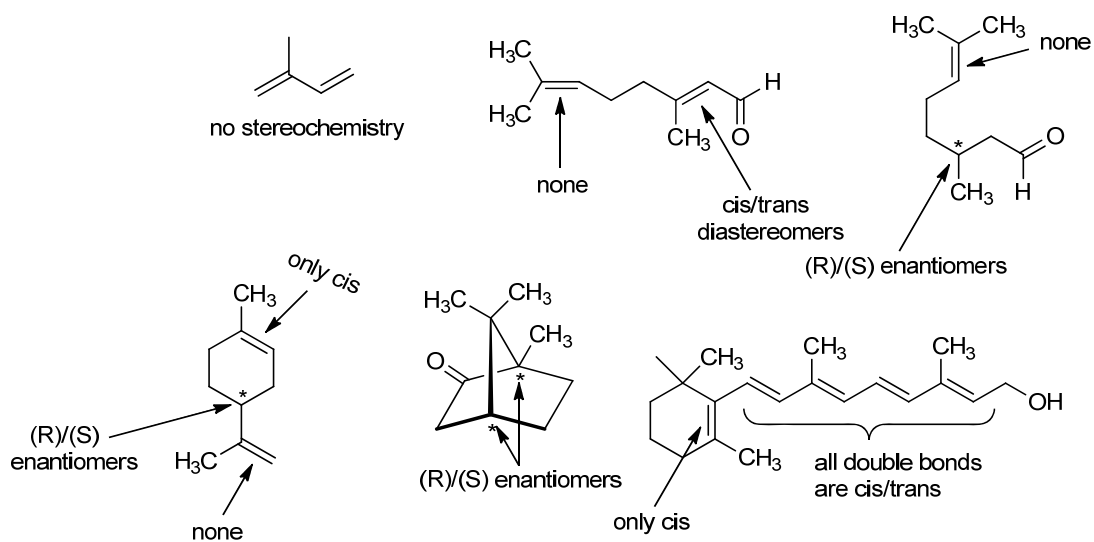

5.4

Let's do it for five of the structures.

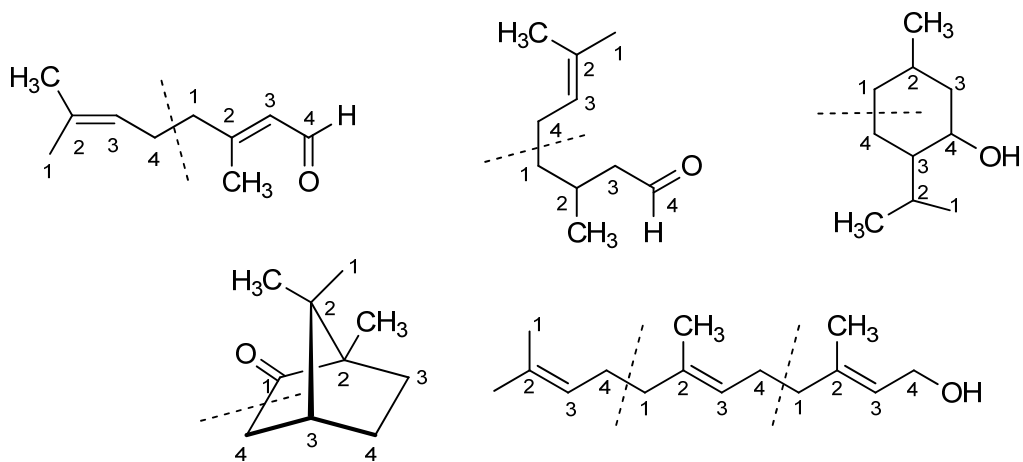

5.5

They are both C<sub>18</sub> fatty acids. Stearic acid is saturated while oleic acid is unsaturated (alkene functional group). Therefore can be made by the same biological source.

No. they can not be synthesized biologically by mechanism which create terpenes because they don't obey the "terpene rule".

5.6

No. Although its biological source is isopentyl diphosphate, (which obeys the terpene rule), there have been several rearrangements during the synthesis of cholesterol.

5.7

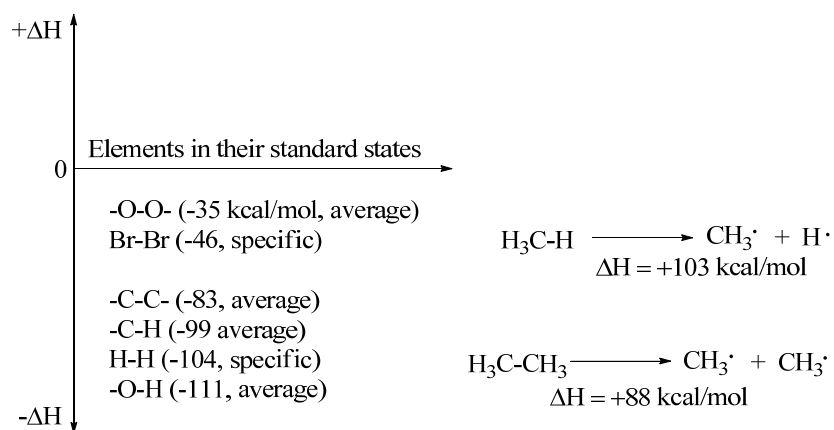

5.8

Because leaving groups are conjugate bases of Brønsted-Lowry acids.

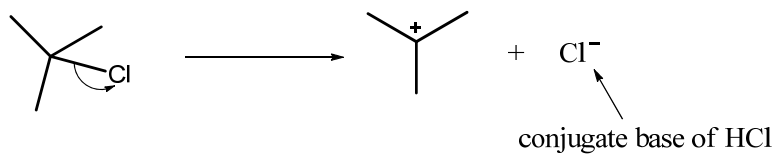

The breaking of the bond between a leaving group and a carbon atom does not necessarily lead to a carbocation. It depends on the nature of the carbon atom, it is bonded to (see for example Figures 11.13 and 11.14 in chapter 11).

5.9

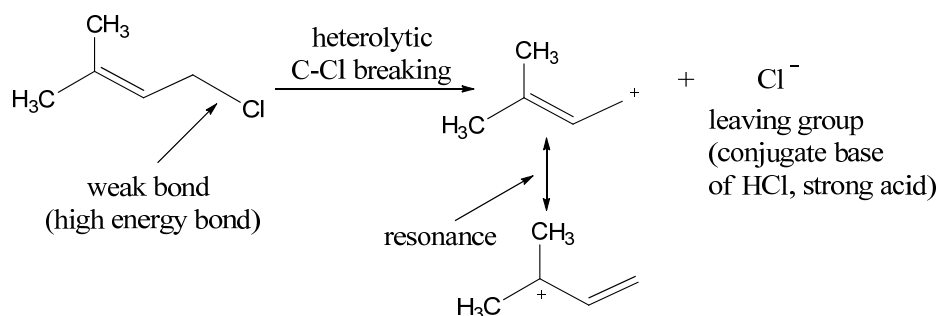

5.10

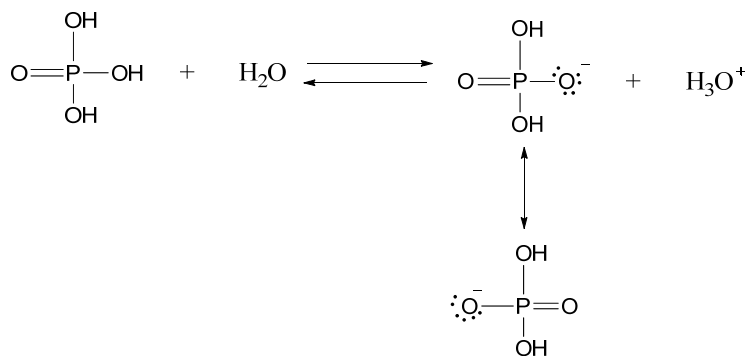

The conjugate base is stabilized by resonance so that the equilibrium is shifted to the right.

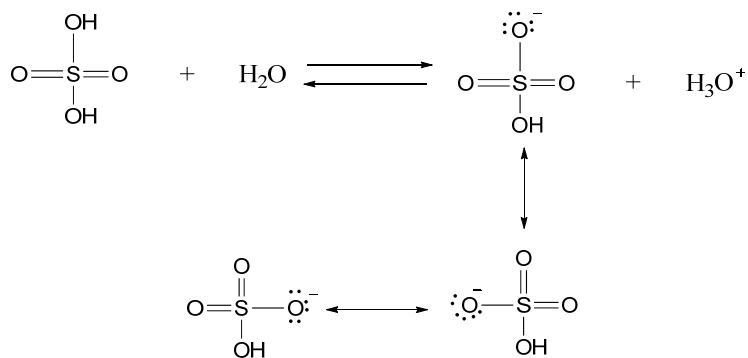

The conjugate base is stabilized by resonance so that the equilibrium is shifted to the right.  $\text{H}_2\text{SO}_4$  is therefore a strong acid.

5.11

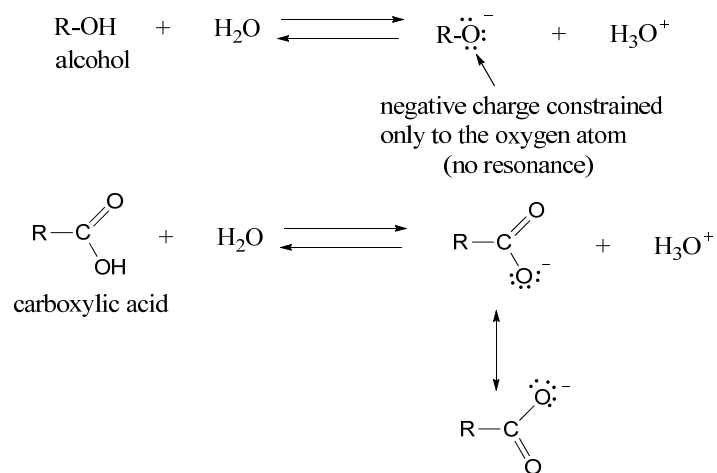

The conjugate base (carboxylate) is stabilized by resonance. Therefore, carboxylic acids are stronger than alcohols.



5.12

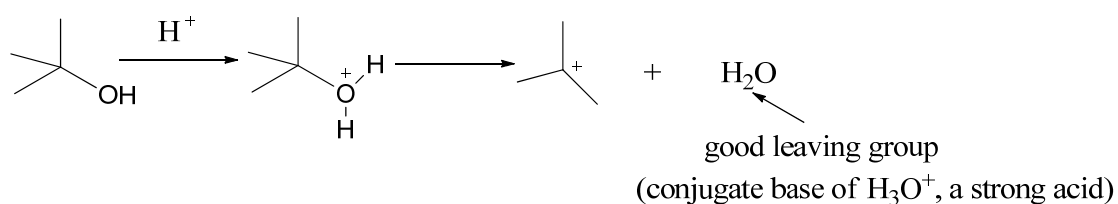
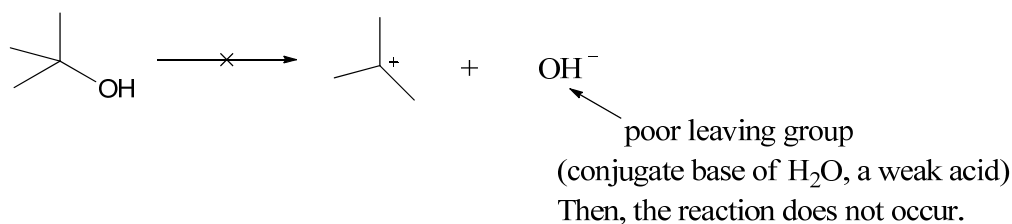
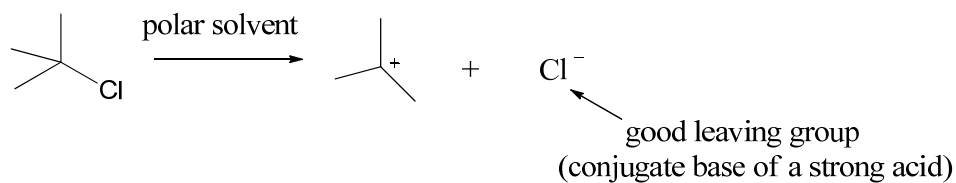

The Bronsted-Lowry acid (H<sup>+</sup>) converts a poor leaving group (OH<sup>-</sup>) to a good leaving group (H<sub>2</sub>O).

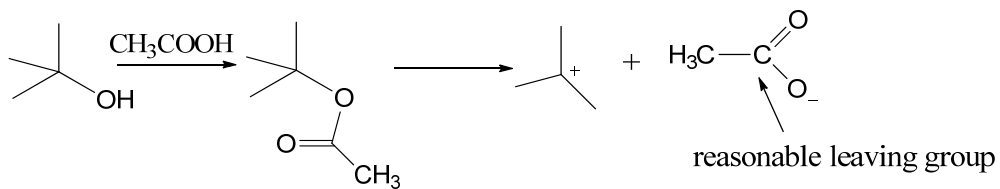

5.13

There are other structures corresponding to the resonance of the following entities:

- Amide groups (2)

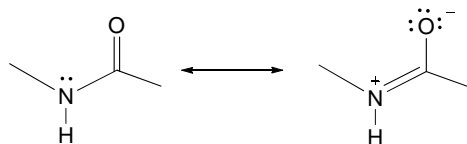

- Phosphate group

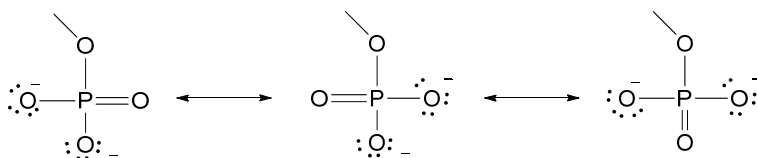

- diphosphate group

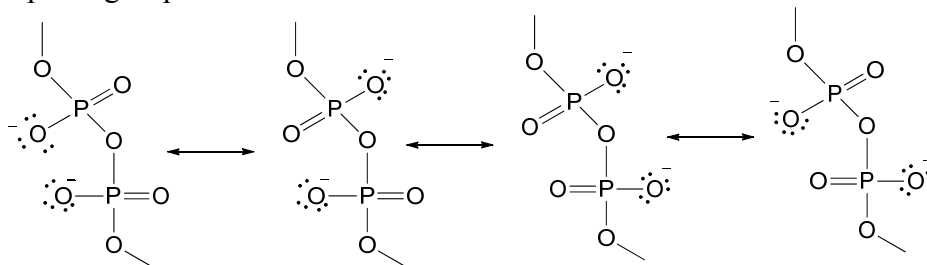

- Adenine residue

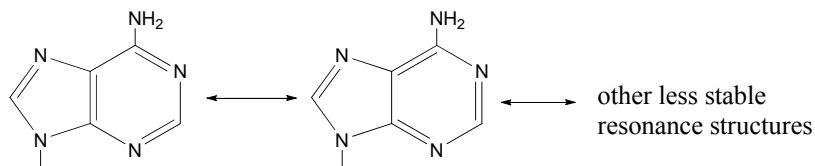

#### 5.14

A resonance structure is reasonable if it contributes to the stabilization of the structure.

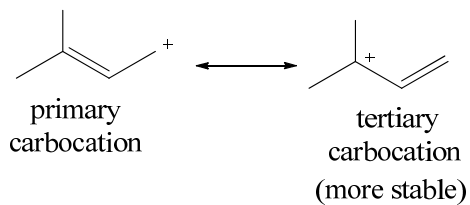

However, more substituted double bond is more stable

- Conformational changes

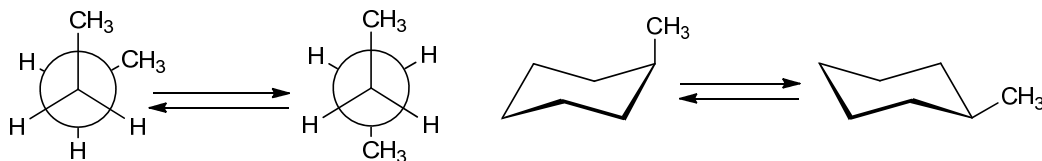

- Chemical reactions

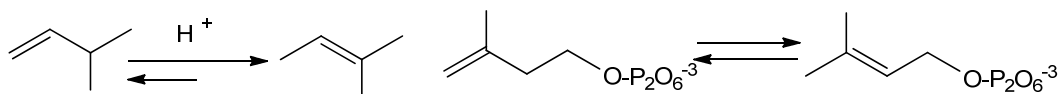

- Resonance structures

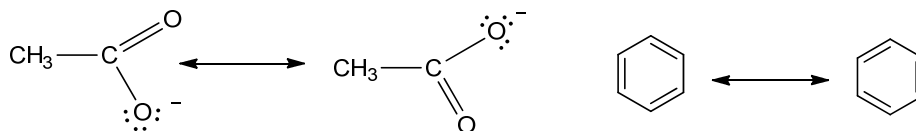

This metaphoric view fits the resonance concept because the more the distribution of electrons, the greater would be the stability of the structures.

It also fits in that the atoms are in constant motion associated with vibraional motions and bond angle motions (scissoring)

5.15

Let's consider:

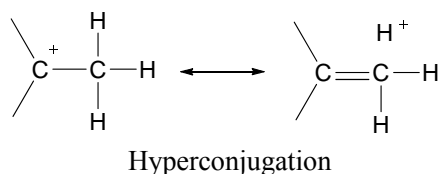

No. hyperconjugation could not be reasonably applied to uncharged hydrocarbons (no empty orbital for accommodation of electrons).

5.16

The double bond C=C and  $-S^-$  of cysteine residue can be viewed as Lewis bases (donators of electrons), while the  $-O-H$  group of the glutamic acid residue and the  $-CH_2$  next to the carbocation can be considered as Brønsted-Lowry acids (donators of protons).

5.17

Yes. In step 1, the leaving group is the glutamate residue (the conjugate base of glutamic acid residue), while in step 2, the leaving group is dimethylallyl diphosphate:

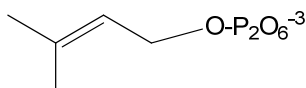

Note that leaving groups are generally weak bases, the conjugate bases of strong acids.

5.18

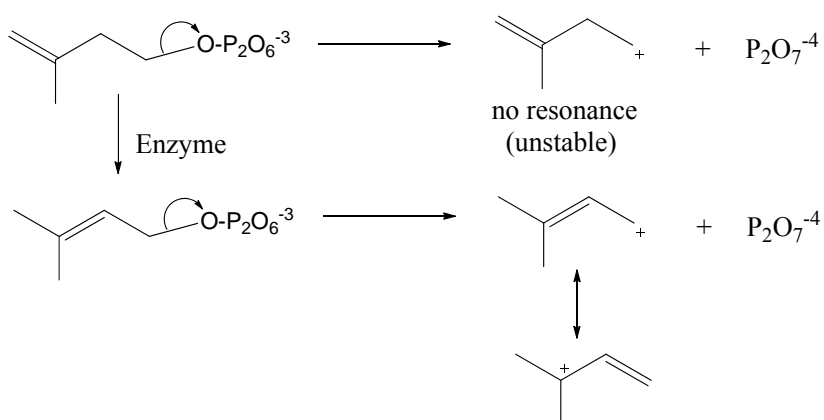

carbocation stabilized by resonance and therefore more easily formed allowing reaction by loss of the  $P_2O_7^{-4}$  group.

5.19

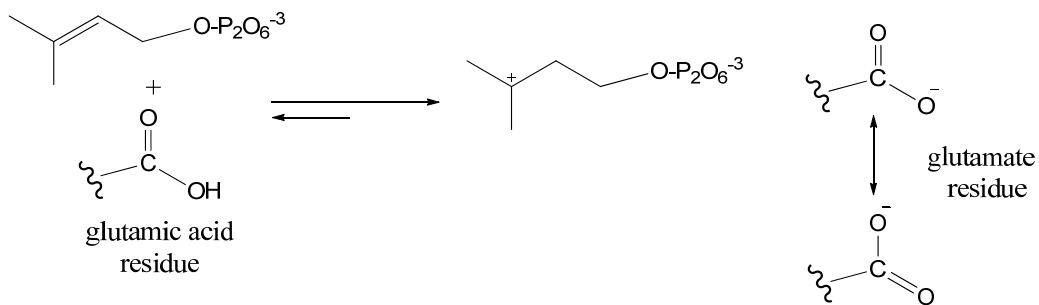

5.20

Yes.

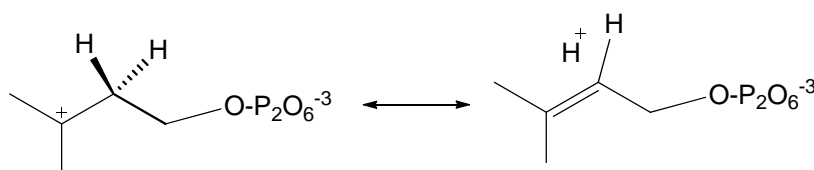

The hyperconjugation would facilitate the departure of the proton in the presence of base.

5.21

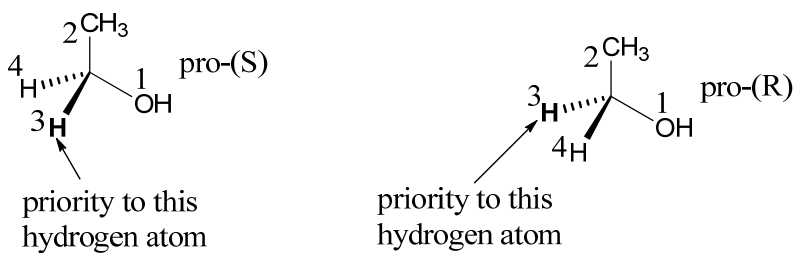

The two hydrogen atoms are enantiotopic.

5.22

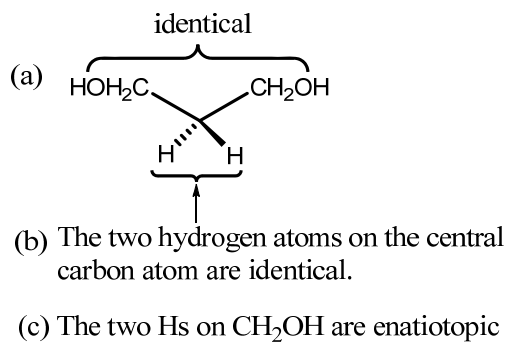
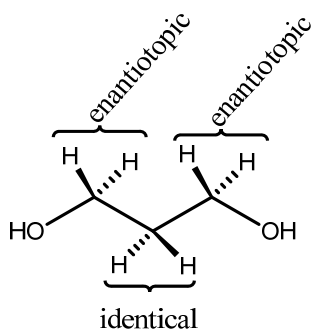

Since enzymatic reactions are stereospecific, the enzyme would be able to distinguish between the two enantiotopic protons of the CH<sub>2</sub>OH group. But, it could not distinguish between the two CH<sub>2</sub>OH groups because they are identical.

5.23

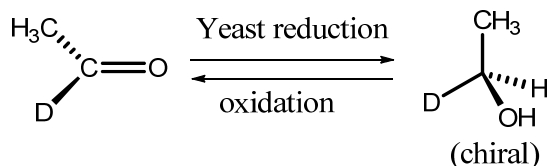

The product is optically active because the faces of the carbonyl group are enantiotopic and the enzyme would prefer one face over the other.

Enzymes are specific, therefore in the oxidative process, the enzyme will catalyze only the C-H breaking, the reverse of the reduction step.

5.24

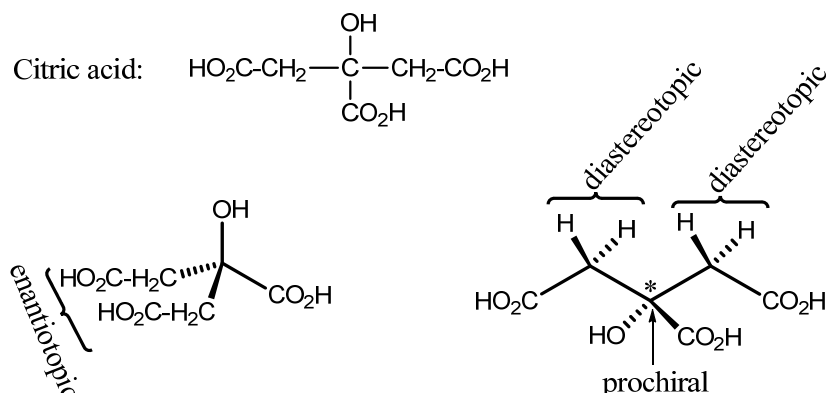

The Hs are related as diastereomers because the central carbon atom is prochiral.

5.25

One example is given by the answer to problem 5.24, where the two Hs of CH<sub>2</sub> groups of citric acid are diastereotopic. Other examples could be the protons on the β-CH<sub>2</sub> group of amino acids.

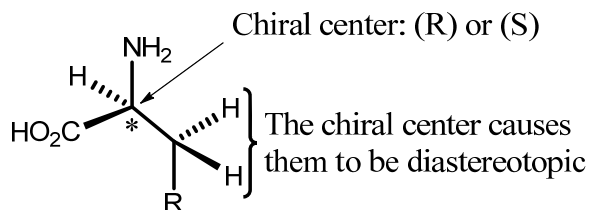

5.26

Both chemical processes involve Lewis acid-base reactions in which the carbocation intermediate (acid) adds to a double bond C=C (base)

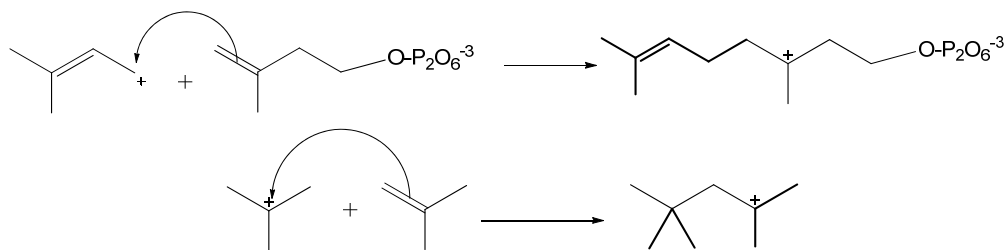

5.27

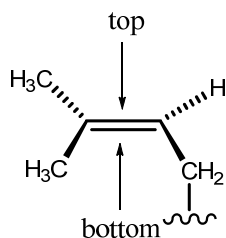

The faces above and below the plane of the C=C double bond are enantiotopic. Therefore, the enzyme would prefer one face over the other. As a result, only one enantiomer is formed.

5.28

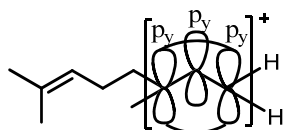
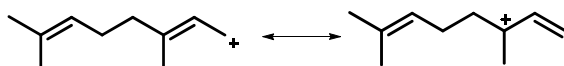

The two π-electrons are distributed in three p-orbitals. Therefore, the C=C bond is intermediate between a C-C single bond and a C=C double bond

$$E(\text{C}-\text{C}) < E(\text{C}=\text{C}) < E(\text{C}=\text{C})$$

E is the energy of activation (section 6.11) necessary for the rotation

5.29

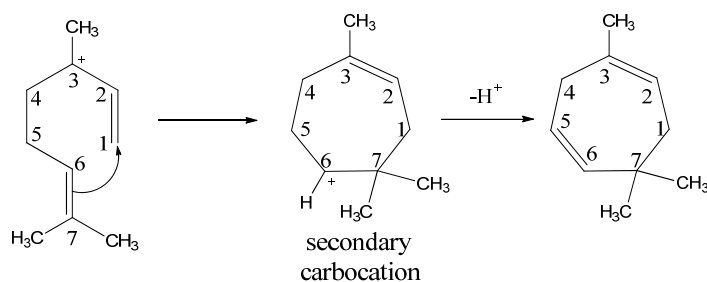

The carbocation formed from C<sub>1</sub>-C<sub>6</sub> ring closing (Fig 5.13) is tertiary and is therefore more stable than the carbocation formed by C<sub>1</sub>-C<sub>7</sub> ring closing (secondary carbocation).

5.30

All electron deficient entities (carbocations or  $H^+$ ) reactions with double bonds ( $C=C$ ) lead to the more substituted carbocation, which lead to terpene structures following the rule as seen in Fig.5.12.

5.31

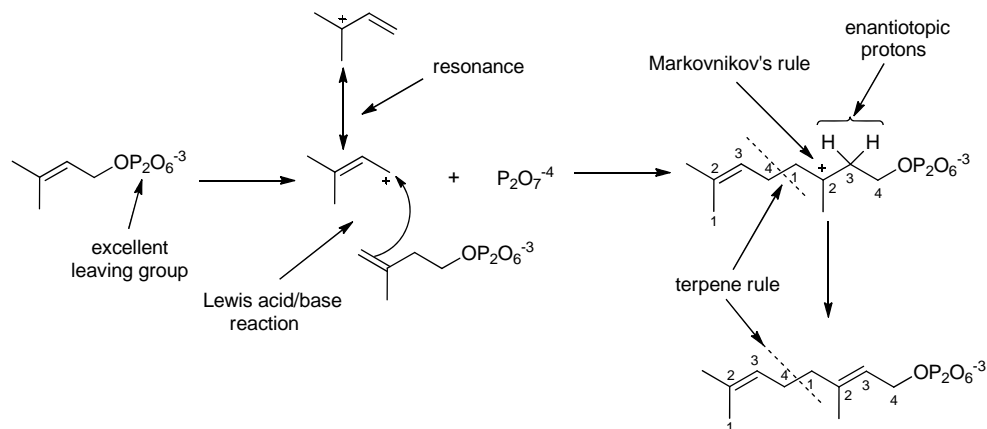

5.32

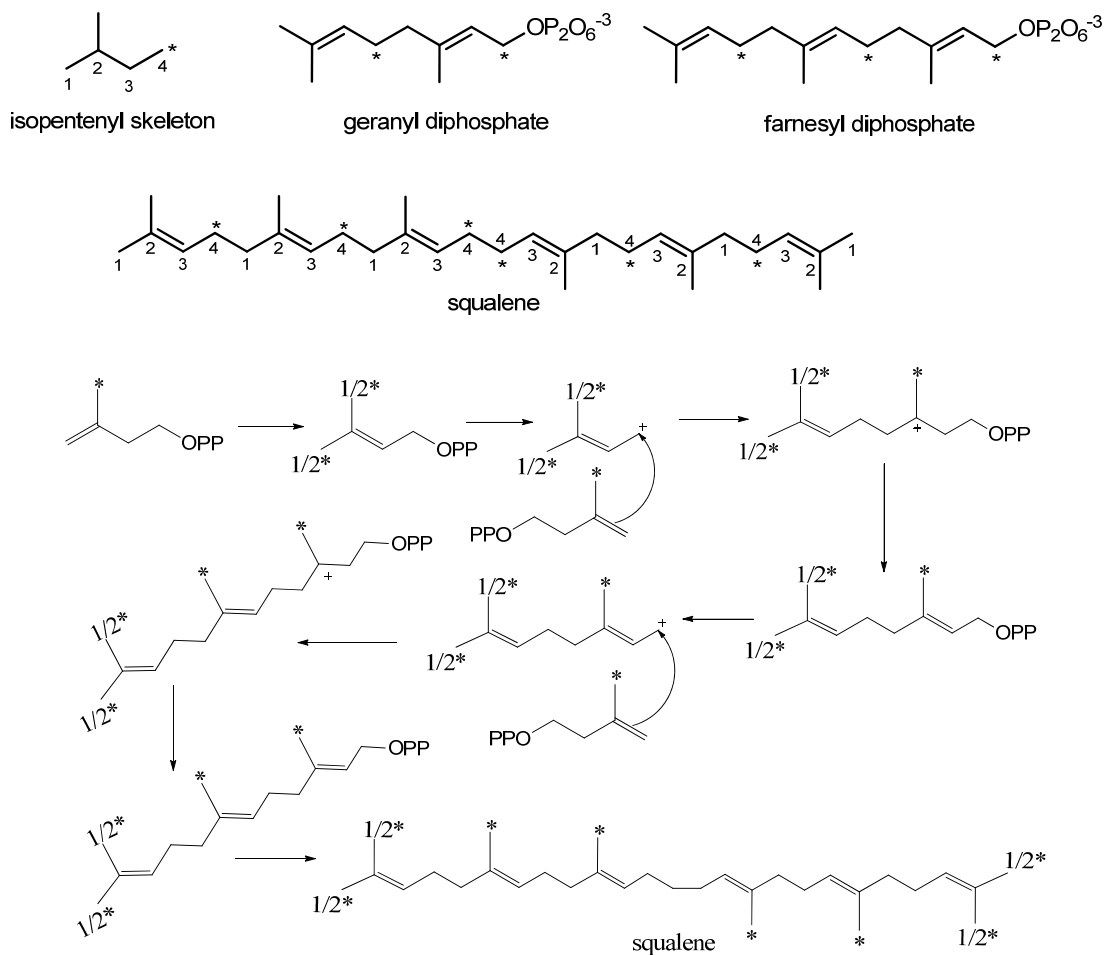

5.33

As seen in Fig.5.18 and 5.19 lanosterol does not obey the terpene rule because of rearrangements.

5.34

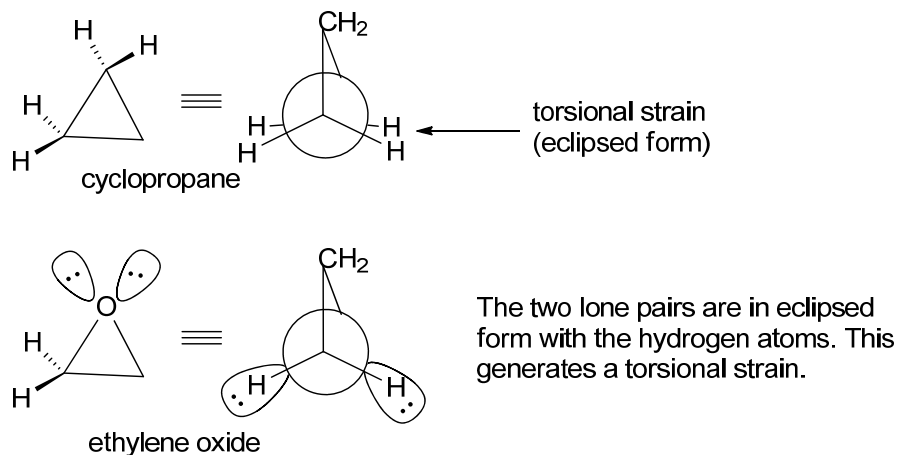

5.35

Yes. The bond angle in cyclopropane and ethylene oxide is  $\sim 60^\circ$ , which is far from the tetrahedral angle. This causes the bending of orbitals forming the bonds between atoms in the ring, leading to "banana-like" shapes.

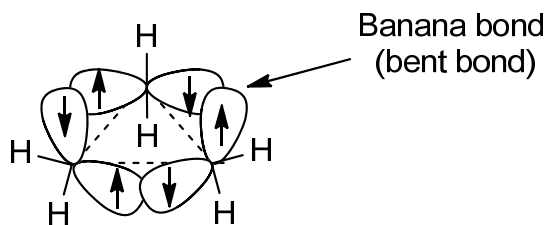

5.36

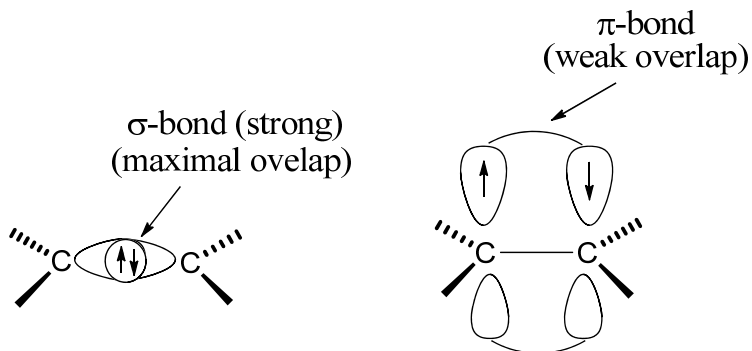



The  $\sigma$ -bond results from overlap of orbitals in the direction of internuclear axis, while the  $\pi$ -bond is formed by overlapping two orbitals perpendicular to the internuclear axis. The three membered ring bonds are intermediate (see direction of bent bonds in 5.35)

5.37



Yes. The large reduction in bond angle in ethylene oxide causes a change in hybridized orbitals due to increased p-character in the O-C bonds and increased s-character in the lone pairs. As a result, this would decrease the basicity of the oxygen atom because the lone pairs of electrons are more strongly related to the nucleus of the oxygen atom and less available to a proton source.

5.38

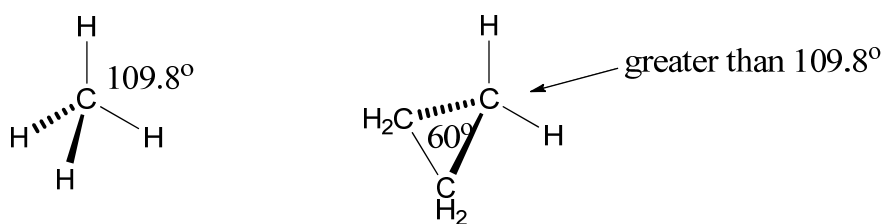

Yes. Considering a perfect tetrahedron ( $109.8^\circ$ ), forcing one angle (C-C-C) to close would cause another (H-C-H) to open. Therefore  $\text{H-C-H} > 109.8^\circ$ .

Yes. The small ring angle ( $60^\circ$ ) leads to an increased p-character in C-C bonds and an increased s-character in C-H bonds. The C-C bonds have  $\pi$ -character (problem 5.36)

5.39

In forming lanosterol from squalene oxide, carbocations are involved in :

- Addition reactions with double bonds (Fig. 5.18)

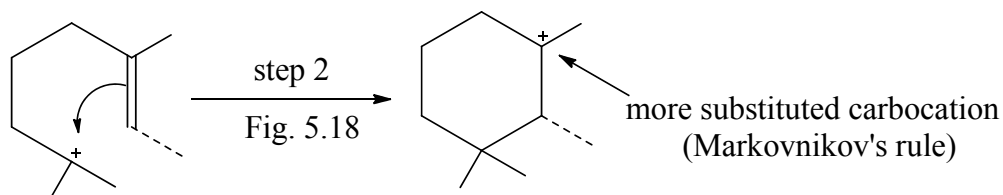

- 1,2- shifts of H and  $\text{CH}_3$  groups (Fig. 5.19)

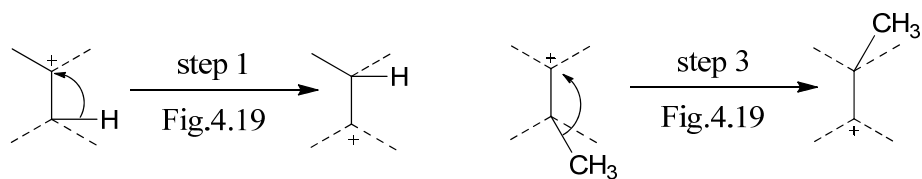

All carbocations are tertiary (stable)

Except step 4 (Fig.5.18) which follows anti-Markovnikov's rule, all other reactions take place in the way of forming the more stable carbocations.

5.40

The addition in step 4 (Fig.5.18) does not obey Markovnikov's rule since it leads to the less stable carbocation (secondary).

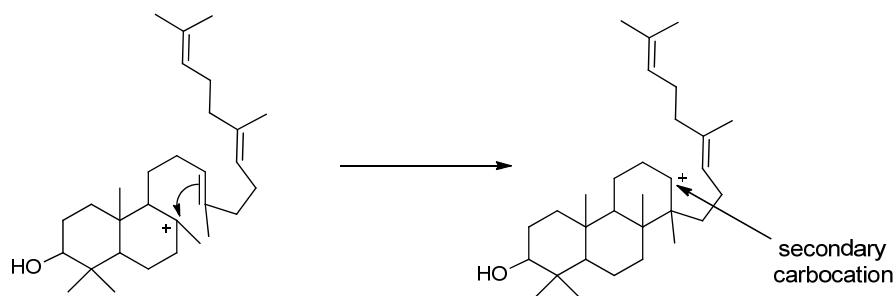

Although the less stable carbocation is formed, this route is preferred to one extent because the five membered ring obtained through Markovnikov's addition would suffer from ring strain (torsional strains). However, there are other reasons associated with the final structures of the steroids formed.

5.41

Because all steps involved in the synthesis of lanosterol from squalene are intramolecular reactions and squalene is a large flexible molecule with many conformational states of which only one is chosen for rings closing.

5.42

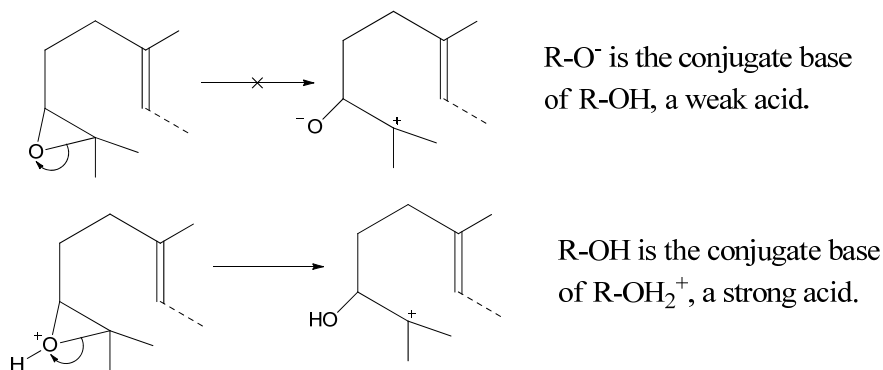

5.43

Let's do it for three of them

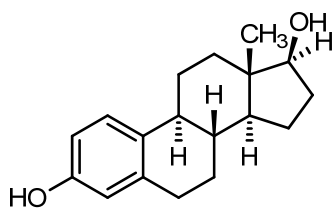
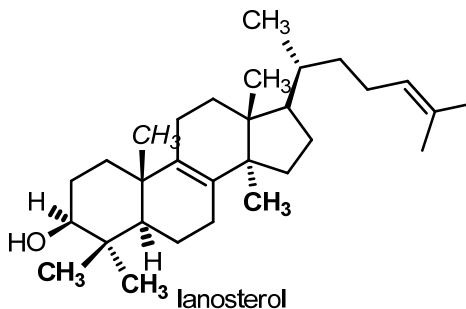

estradiol

For conversion of lanosterol to estradiol, we need to:

- remove four methyl ( $\text{CH}_3 + \text{CH}_3$ ) groups from the rings.

- substitute the pendant group attached to the five membered ring by the  $-\text{OH}$  group.

- convert the first ring to a phenol ring

- saturate the double bond in the second ring

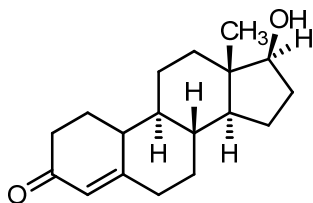

testosterone

For conversion of lanosterol to testosterone,

- follow steps (a) and (b) for estradiol

- oxidize  $-\text{OH}$  to ketone ( $\text{C}=\text{O}$ )

- move the double bond ( $=$ ) in order to form an enone with the ketone

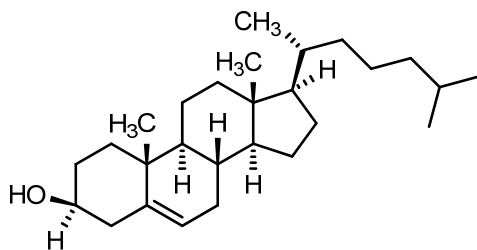

cholesterol

For conversion of lanosterol to cholesterol,

- remove three methyl ( $\text{CH}_3$ ) groups

- move the ring double bond ( $=$ )

- saturate the linear double bond ( $=$ )

## Chapter 6

### 6.1

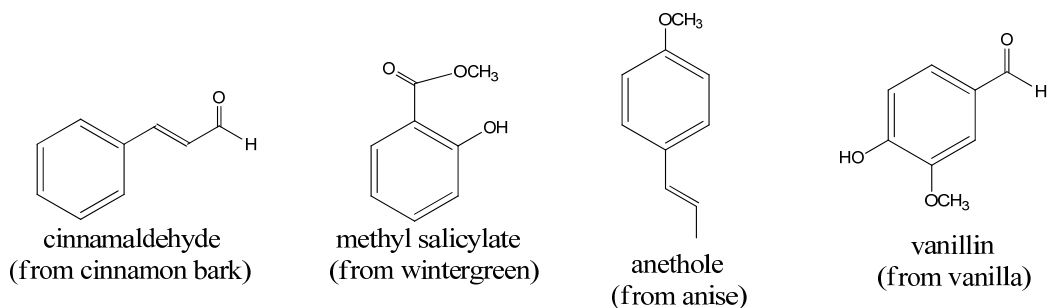

None obey the isoprene rule.

### 6.2

Let's give some examples

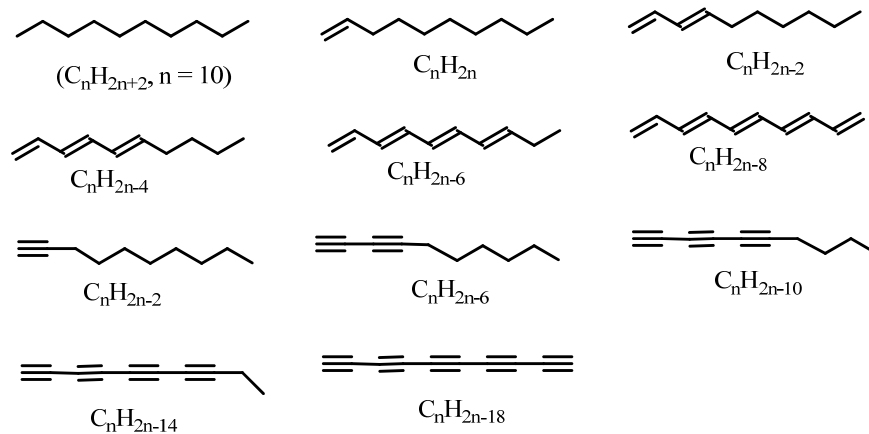

### 6.3

The formula of a molecule with a triple bond should be:  $C_nH_{2n-2}$

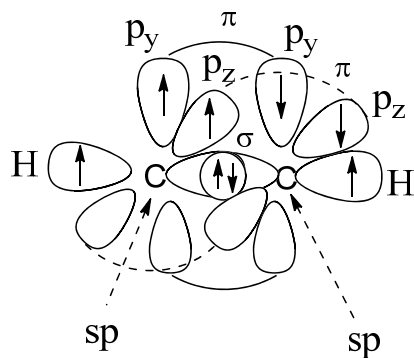

$H-C\equiv C-H$  (acetylene)

- hybridization:  $sp$
- geometry: linear
- one  $\sigma$ -bond C-C
- two  $\pi$ -bonds

6.4

Formula : C<sub>6</sub>H<sub>6</sub> (acyclic)

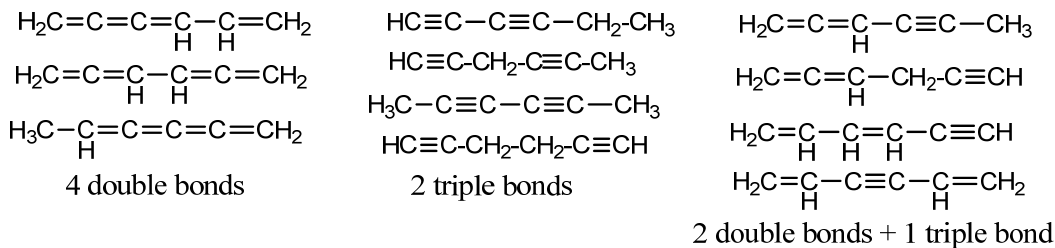

extent of unsaturation = 4

For a hydrocarbon C<sub>x</sub>H<sub>y</sub>, the extent of unsaturation =  $n(\text{C}) + 1 - n(\text{H})/2 = x + 1 - y/2$  which in this case (x = y = 6) is 4.

6.5

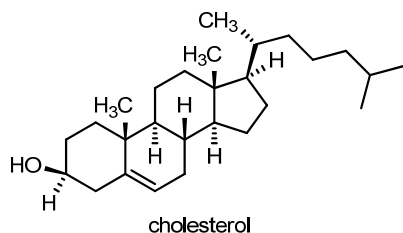

Number of carbon atoms = 27

Number of H atoms for saturated structures (expected) =  $2 \times 27 + 2 = 56$

4 cycles (less 2H/cycle) = -8

1 double bond (less 2H/double bond) = -2

Total of H atoms = 46

Taking into account the oxygen atom, the expected formula is: C<sub>27</sub>H<sub>46</sub>O. Cholesterol has a total of 46 hydrogen atoms ( counting) which is in agreement with the calculation.

6.6

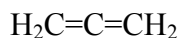

The formula of allene is: C<sub>3</sub>H<sub>4</sub> which is consistent with the structure with two double bonds and no ring (C<sub>n</sub>H<sub>2n-2</sub>; n=3).

6.7

Yes.

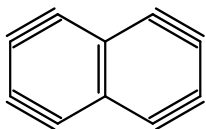

(C<sub>n</sub>H<sub>2n-20</sub>, n = 10)

- formula: C<sub>10</sub>

- number of insaturations = 11

(2 cycles, 1 double bond, 4 triple bonds)

- no hydrogen atom

However, triple bonds are linear. Therefore the structure shown would be impossible.

6.8

Let's do it for few of those structures.

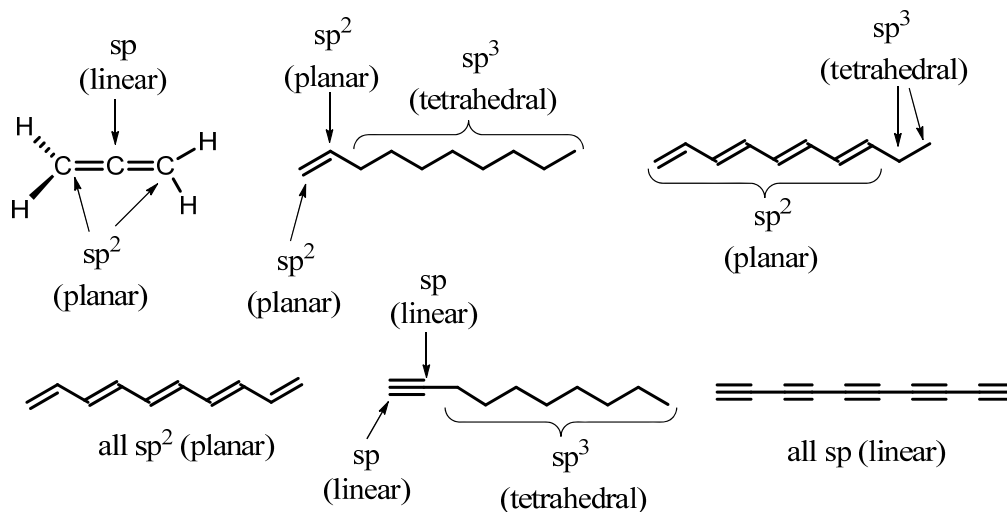

6.9

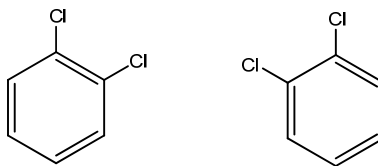

There should be two different possibilities since C=C and C-C bonds would be different. Therefore, they would be *structural isomers*.

6.10

1) Addition of X-Y

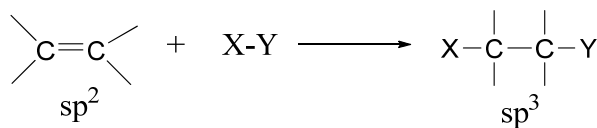

Breaking of the  $\pi$ -bond and change of hybridization of the atoms involved from  $sp^2$  to  $sp^3$ .

2) Substitution of H by X

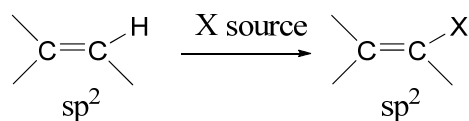

No breaking of the  $\pi$ -bond and no change in the hybridization of the atoms connected by the double bond.

### 6.11

Because in reality there are no double bonds in the structure of benzene. Two resonance structures with double bonds represent a structure in which the 6  $\pi$  electrons are delocalized as :

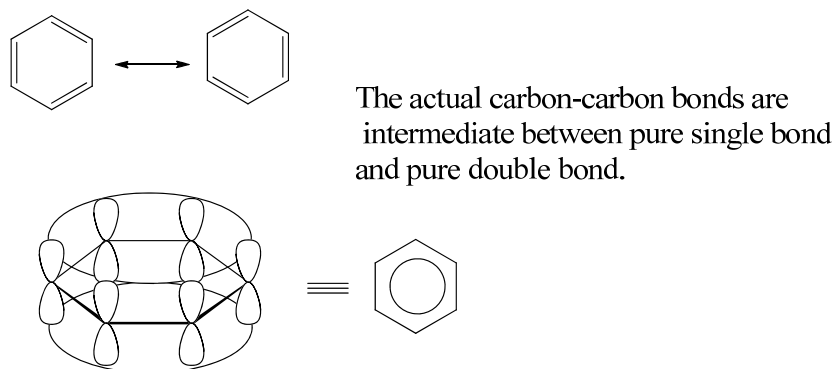

The delocalization of the  $\pi$ -electrons in benzene gives the molecule a special stability, aromaticity, which causes a higher energetic price to break the  $\pi$ -delocalized system, which would happen by substitution.

### 6.12

1,2,3,5 is preferable because according to IUPAC convention, the sum of the numbers used to name a compound must be the smallest possible.

$1+2+3+5=11$  while  $1+3+4+5=13$ .

### 6.13

Because in disubstituted benzenes, one substituent can be only in 2-position(ortho), 3-position (meta) or 4-position (para) in reference to another.

### 6.14

If the positions of double bonds are fixed, we expect to have three double bonds and three single bonds in the benzene ring. Therefore, there would be two possible isomers for 1,2,3,4-tetrachlorobenzene

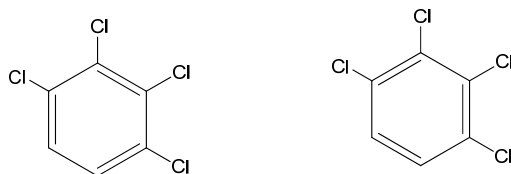

For the other two structural isomers, the double bond positions would make no difference.

### 6.15

If the structure of benzene was composed of alternate fixed double bonds and single bonds, one would expect a distorted hexagon (the double bond and the single bond have different lengths ). However, the experimental evidence shows that benzene ring is a perfect hexagon demonstrating that all six carbon-carbon bonds are identical.

6.16

Considering each carbon atom is  $sp^2$  hybridized, all three bond angles around each carbon atom should be identical ( $120^\circ$ ). As a result, all internal angles of the hexagon should be equal, leading to a perfect hexagon with all C-C bonds being of the same length.

If the ring plane is (xz) perpendicular to the page, s,  $p_x$ ,  $p_z$  orbitals would participate in the hybridization and  $p_y$  orbitals belonging to the plane of the page would form  $\pi$ -bonds.

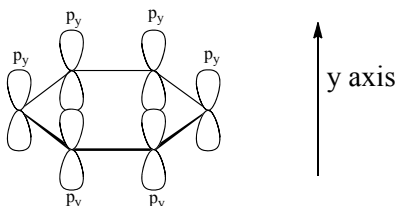

6.17

Not quite. The energy released does not arise only from breaking of  $\pi$ -bonds but rather from the balance between the bonds made (C-H) in such a reaction and the bonds broken (H-H and  $\pi$ -bonds). The negative energy evolved means that the bonds made are stronger than the bonds broken.

6.18

Hydrogenation of the three alkenes leads to the same product (n-butane). Therefore, the difference in  $\Delta H$  is only associated with the variation in their structures.

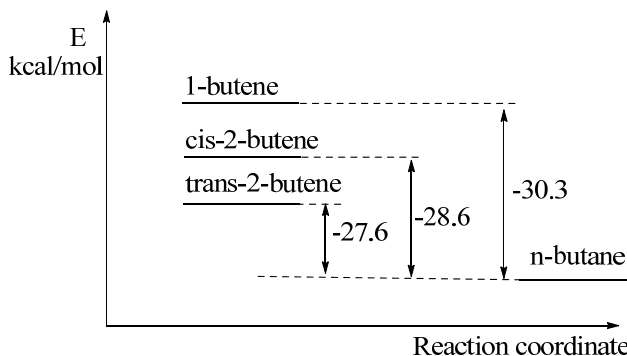

The following order of stability can be made:

**(least stable) 1-butene, cis-2-butene, trans-2-butene (most stable)**

6.19

The conclusion to be drawn from these facts is that in 1,3-cyclohexadiene, the two double bonds should be considered as normal double bonds in cis-conformation ( $-\Delta H = 2 \times 28.6 = 57.2$  kcal/mol). While in benzene the energy released is smaller than three times the energy of the cis-double bond because of the stabilization of the structure by resonance ( $\Delta H_{\text{resonance}} \approx 36$  kcal/mol).

6.20

The free energy of the reaction is:  $\Delta G = \Delta H - T\Delta S$



$\Delta S$  is the entropy cost arising from combining two molecules, benzene and hydrogen, to form one molecule and should therefore be negative. Increasing  $T$ , the unfavorable term  $-T\Delta S$  should become more positive. As a result, the free energy term ( $\Delta G$ ) which is negative from the large negative  $\Delta H$  term will become less negative (the equilibrium constant decreases) and the equilibrium is therefore shifted to the left, toward the reactants.

### 6.21

By hydrogenation:

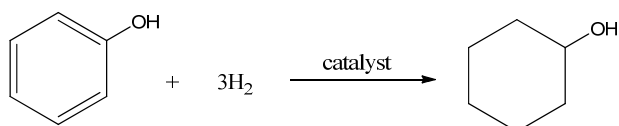

Because both benzene and cyclohexane are six membered rings and under certain conditions, the hydrogenation of benzene can be carried out with the appropriate catalyst.

### 6.22

Cyclooctatetraene does not obey Hückel's ( $4n+2$ ) rule ( $8-\pi$  electrons) and is therefore not aromatic. The four double bonds can be viewed as isolated double bonds in cis-conformations.

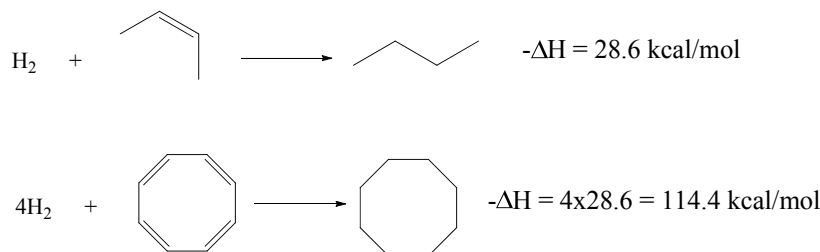

### 6.23

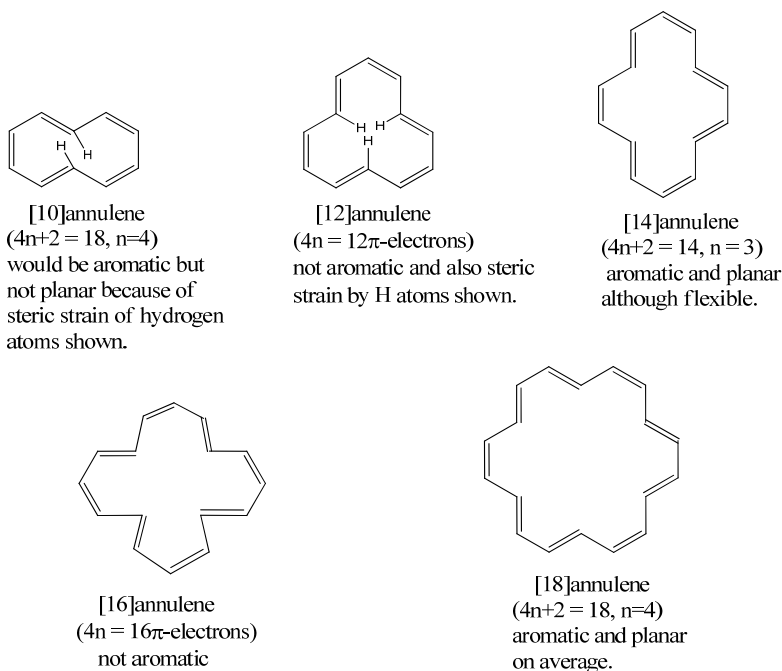

[14] and [18]annulenes are aromatic and will therefore undergo substitution rather than addition.

6.24

Benzene's structure has no formal charge with the number of  $\pi$ -electrons, 6, equal to the number of non-hybridized p orbitals. Furthermore, it is a perfect hexagon with internal angle of  $120^\circ$  (no angle strain is present). Most important it has completely filled bonding orbitals, an equivalent of the completely filled atoms orbitals of a noble gas.

6.25

A perfect pentagon should have an internal angle of  $108^\circ$  which causes some angle strain. However, the main deviation from the "perfection" of benzene is the necessary negative charge.

6.26

Because the carbocation formed is aromatic with 6  $\pi$ -electrons, and is therefore highly stabilized by resonance.

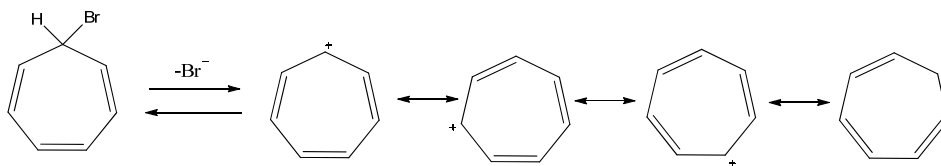

6.27

The carbocation ( $C_5H_5^+$ ) obtained by breaking the C-Br bond is not aromatic, 4  $\pi$ -electrons (does not obey the  $(4n+2)$  rule), therefore, it would be difficult to form.

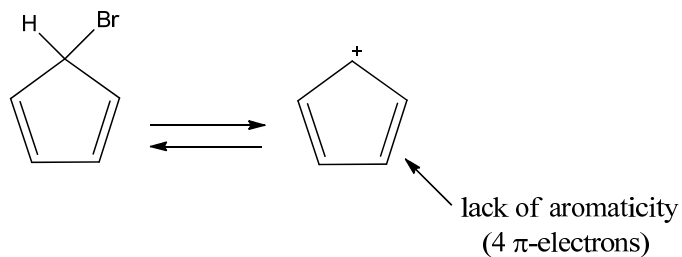

6.28

Because the conjugate base of cyclopentadiene (cyclopentadiene anion) is aromatic and is therefore highly stabilized, while the cycloheptatriene anion is not aromatic.

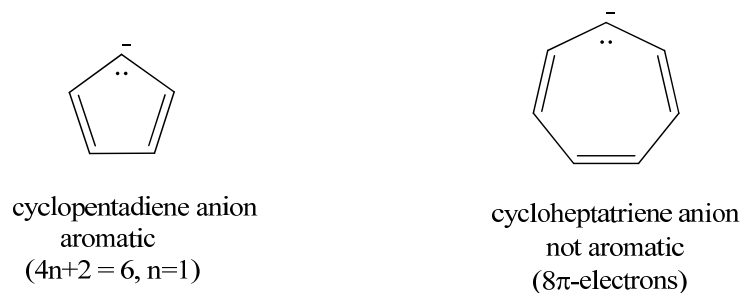

6.29

Cyclopropene cation( reaction 1), cyclopentadiene anion(reaction 3) and cyclooctatetraene anion(reaction 5) obey the  $(4n+2)$  rule and are therefore aromatic, while cyclopropene anion(reaction 4) and cyclopentadiene cation (reaction 2) are not aromatic. Therefore, they are less easily formed.

6.30

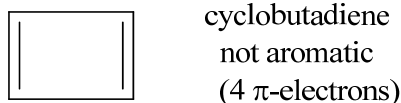

Symmetrical cyclobutadiene has 4  $\pi$ -electrons and is therefore not aromatic. Furthermore, the four membered ring suffers from angle strain (internal angle =  $90^\circ$ ). This makes it less stable and therefore difficult to synthesize. The two double bonds would act as isolated double bonds and would therefore be shorter than the single bonds. Cyclobutadiene has been synthesized by extraordinary methods and the bond lengths measured. The molecule is a rectangle with sides: 1.567 Å and 1.346 Å.

6.31

The numbers given for “y” obey the  $(4n+2)$  rule and therefore represent the number of  $\pi$ -electrons required for aromatic character.

These “y” electrons would be filled only in molecular orbitals with positive (bonding) or zero (non-bonding) level coefficients, which are the only ones responsible for the aromatic character.

6.32

The (+) signs designate that the corresponding molecular orbitals are more stable than the original atomic orbitals, while the (-) sign means that the corresponding molecular orbitals have energy greater than that of the atomic orbitals. Only the electrons filled in orbitals with positive (bonding) and zero (non-bonding) signs contribute to the aromatic character of a molecule. Molecular orbitals with negative signs (anti-bonding) act to disrupt the potential aromatic character.

6.33

Let's ignore the sugar phosphate units.

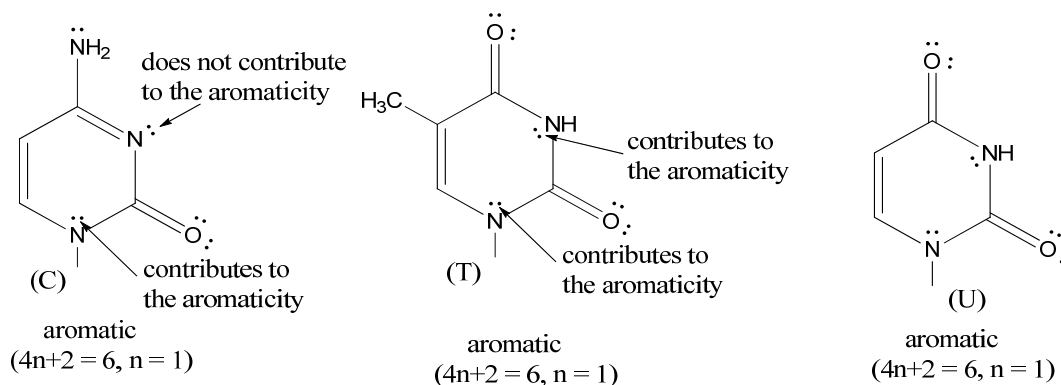

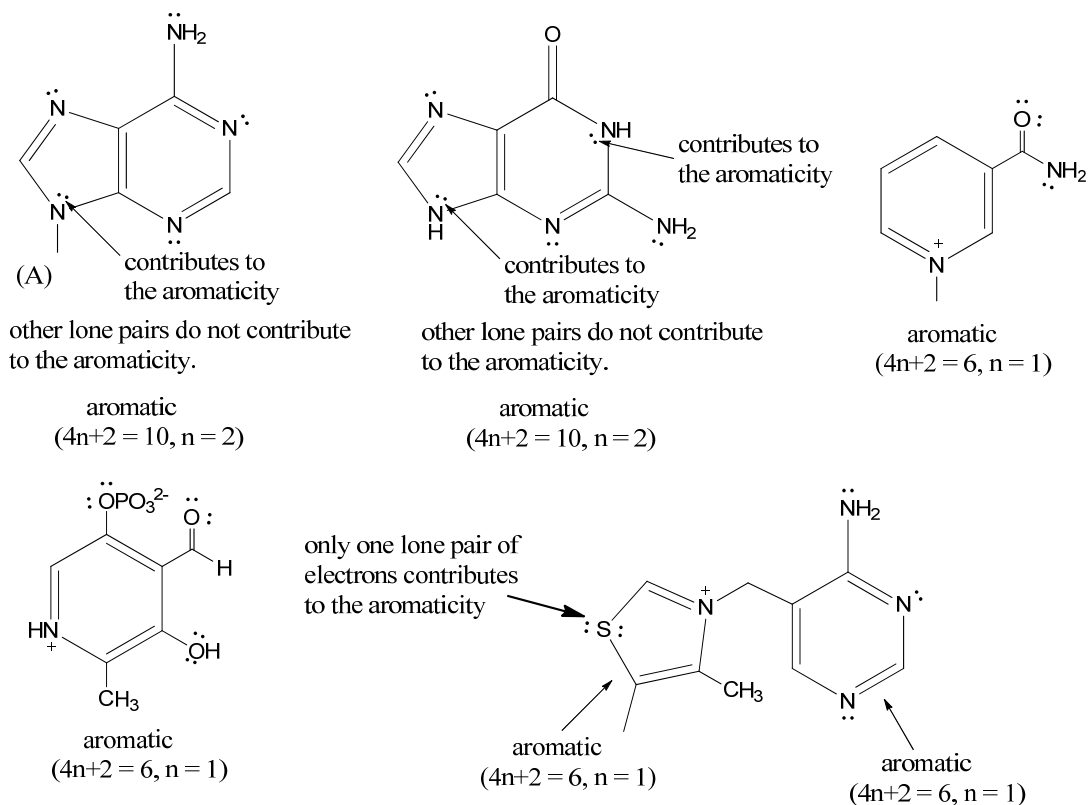

Lone pairs of electrons in  $sp^3$  orbitals contribute to the aromaticity while the ones in  $sp^2$  orbitals do not affect the aromatic character.

6.34

Fig. 6.13

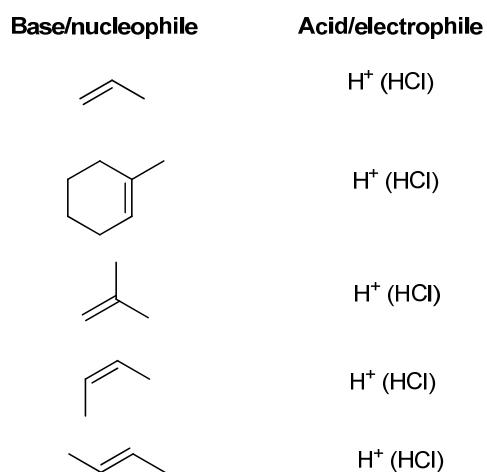
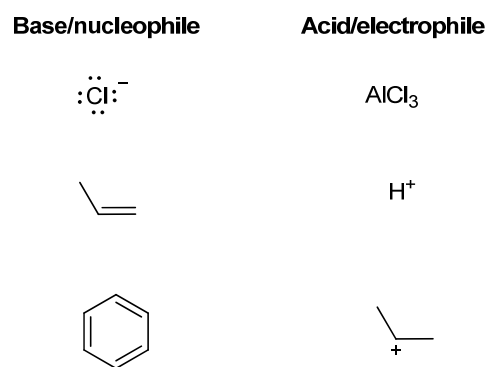

Fig. 6.14



Yes. Bases are always nucleophilic and acids are always electrophilic.

6.35

Reactions of the two diastereomers (trans-and cis-2-butene) with the proton leads to the same carbocation intermediate:

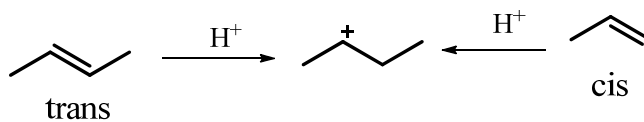

and would therefore give the same product by subsequent addition of  $\text{Cl}^-$ .

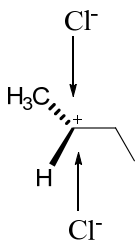

Both faces of the carbocation are enantiotopic and addition would lead to formation of a racemic mixture (equal amount of the two enantiomers of 2-chlorobutane).

6.36

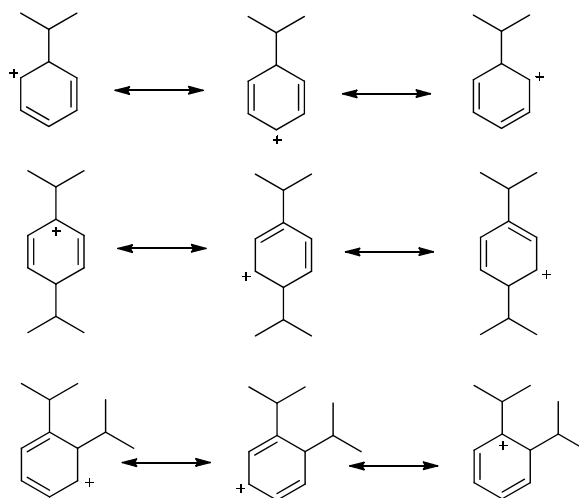
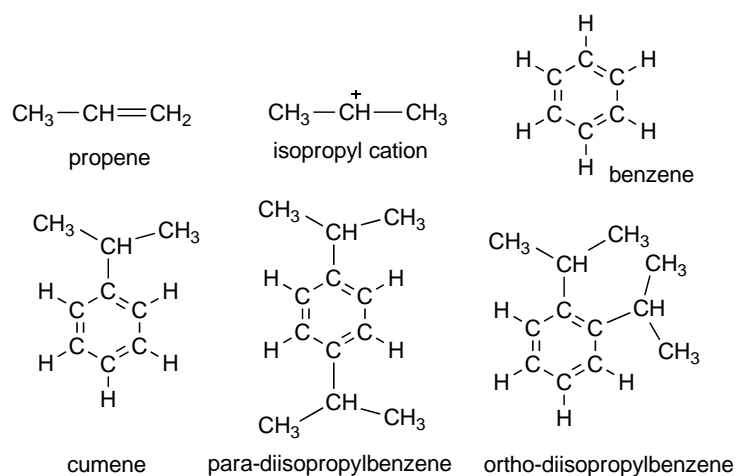

The proton lost in the last step should be the proton on the carbon atom adjacent to the carbocation so as to restore the aromaticity of the system.

6.37

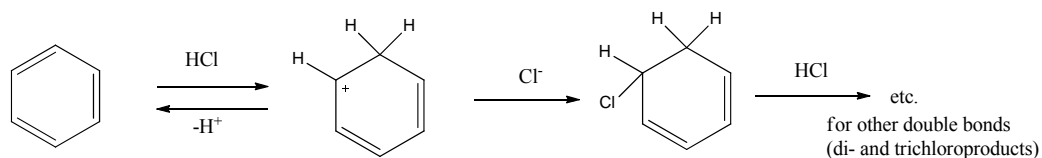

6.38

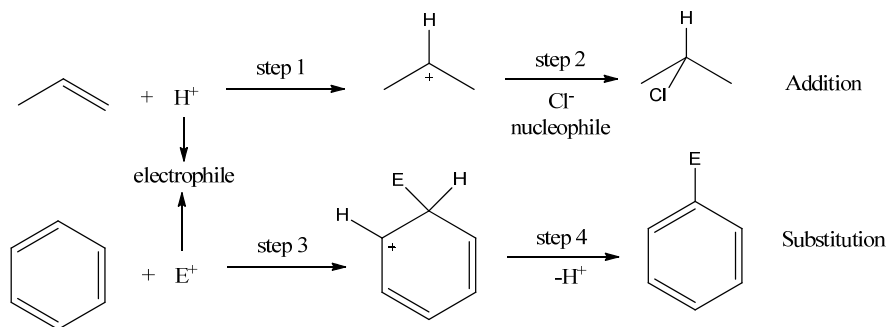

a) *Step 1 versus step 3*

Alkenes are good nucleophiles (isolated double bond) while benzene is a poor nucleophile due to the resistance to interrupt the 6  $\pi$ -electrons aromaticity. As a result, *step 1* is faster than *step 3* (higher energy of activation)

b) *Step 2 versus step 4*

Isopropyl cation is highly reactive (electron deficient) while phenyl cation is stabilized by resonance and would therefore become less reactive. However step 4 is driven by the returning aromatic character so that both 2 and 4 could be fast.

6.39

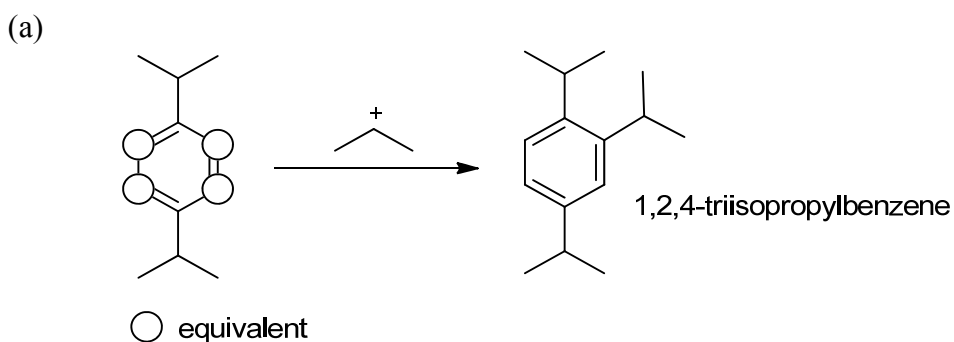

Para-diisopropylbenzene is symmetrical and the four available substitution sites are equivalents. Therefore, the attack of a third isopropyl group would lead to a unique product: *1,2,4-triisopropylbenzene*.

(b)

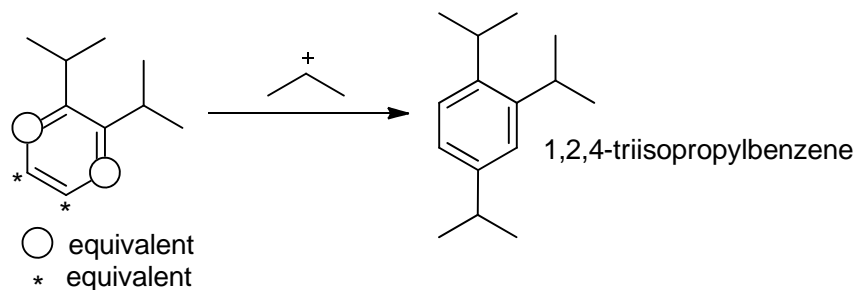

Although ortho-diiisopropylbenzene has two different positions available for electrophilic attack, mostly 1,2,4-triisopropyl derivative would be obtained. The other product (1,2,3-triisopropylbenzene) is less likely to form due to steric strains generated by three isopropyl groups in close proximity.

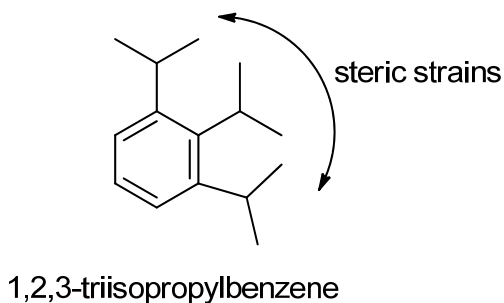

6.40

1)

$$\text{Reaction 1: } k_1 = Ae^{-E_a/RT_1}$$

$$\text{Reaction 2: } k_2 = Ae^{-E_a/RT_2}; T_2 = T_1 + 10$$

Let's assume :  $E_a = 20 \text{ kcal/mole}$ ;  $T_1 = 298\text{K}$  ;  $R = 1.984 \text{ cal/mole.K}$

$$k_2/k_1 = e^{-E_a/R(1/T_2 - 1/T_1)} = \text{Exp} [-20000 (1/308 - 1 / 298)/1.984 ] = 2.999$$

$$\mathbf{k_2/k_1 \approx 3}$$

Increasing the temperature by  $10^\circ\text{C}$ , the rate constant increases by a factor of 3.

2)

$$\text{Reaction 1: } k_1 = Ae^{-E_{a1}/RT}$$

$$\text{Reaction 2: } K_2 = Ae^{-E_{a2}/RT}$$

$E_{a1} = 20 \text{ kcal/mole}$ ;  $E_{a2} = 25 \text{ kcal/mole}$ ;  $T = 298\text{K}$

$$k_1/k_2 = e^{-(E_{a1} - E_{a2})/RT} = \text{Exp} [-(20000-25000) / 1.984 \times 298] = 4707.52$$

$$k_1 k_2 \approx 4707$$

Increasing the energy of activation by 5 kcal/mole, the rate constant decreases by a factor of around 4700.

6.41

The limiting step (rate determining step) is the interaction between benzene or deuterated benzene and the isopropyl cation. Since this step does not involve the C-D or C-H bonds, it would have similar energies of activation for both substrates. The next step, which involves breaking of the C-H or C-D bond is so much faster than the first step that the rate is not affected by the Eact difference for C-H versus C-D.

6.42

1)

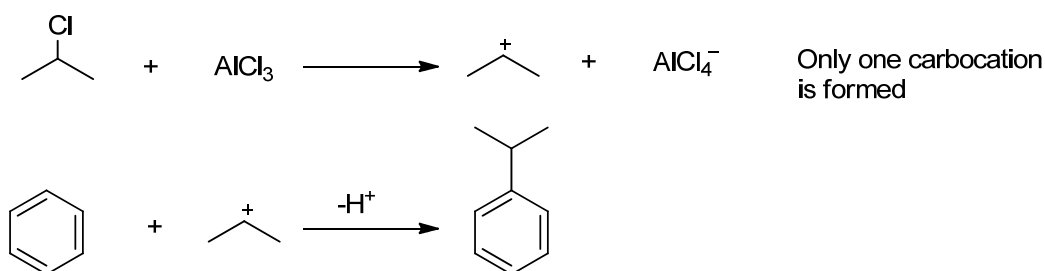

2)

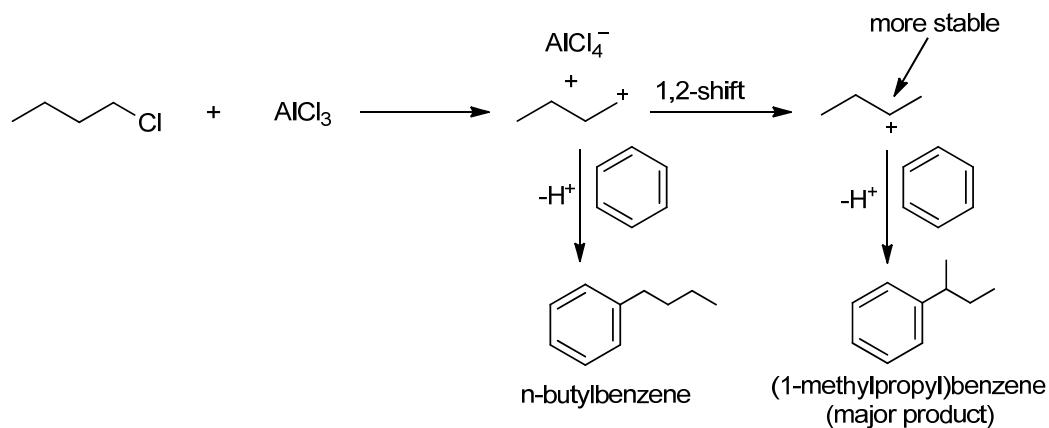

Two butyl carbocations are present (1,2-shift) and would lead to two butylbenzene derivatives.

6.43

The acylium ion is stabilized by resonance and no rearrangement occur because there is no open p orbital on carbon. The resonance structure with the positive charge on oxygen (reaction 1 below) is important (see the answer to problem 6.44).



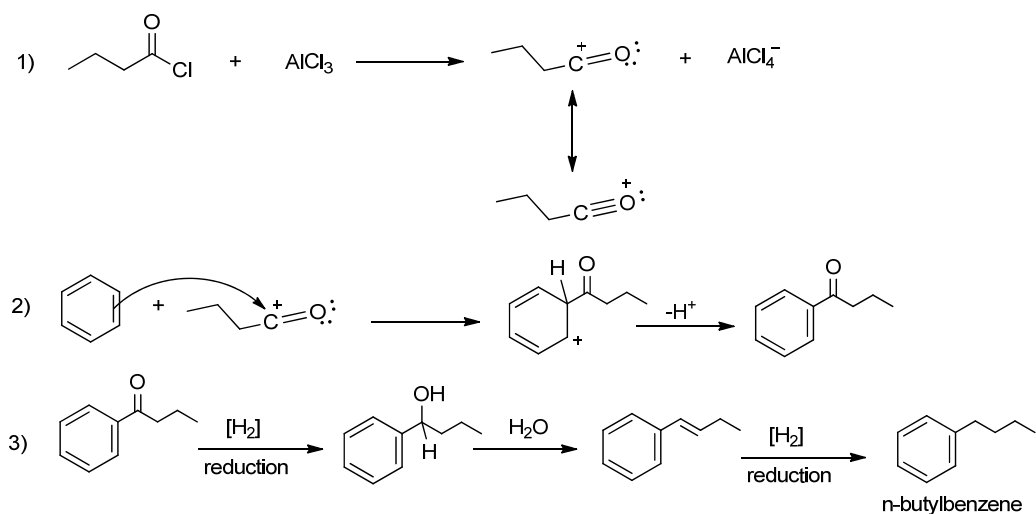

There are other methods for the reactions in 3).

6.44

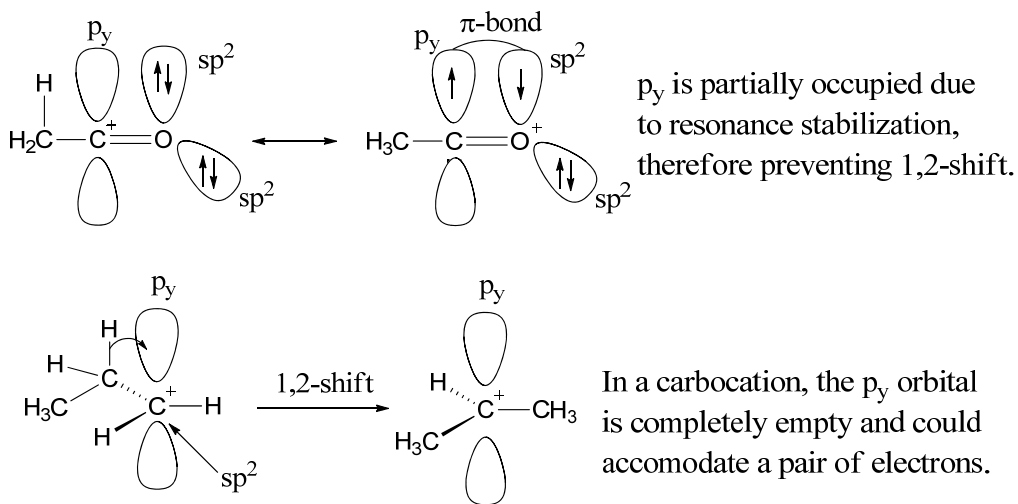

6.45

In multialkylation of benzene, the major products obtained are the ones from the most stable intermediate carbocations. For example in the reaction of isopropyl cation with cumene, the *ortho*- and *para*- derivatives are the major products due to the higher stability of one of the resonance structures of the carbocation.

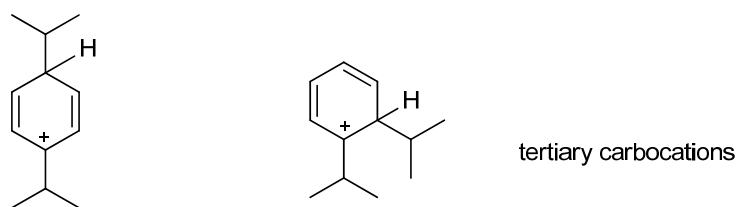

They give the major contribution on the resonance structures.

*Meta*-substitution constrains the positive charge only to secondary carbon sites. As a result, the energy of activation would be greater than that of *ortho* and *para*.

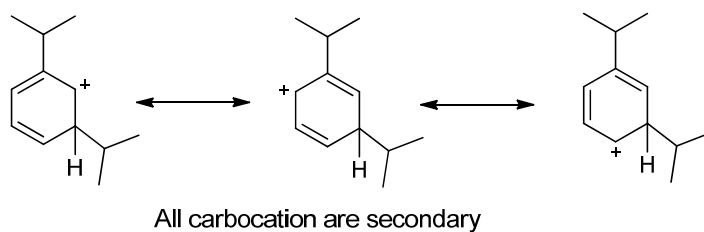

6.46

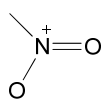

-NO<sub>2</sub> is an electron withdrawing group (positive charge on the nitrogen atom)

1) *Para* derivative

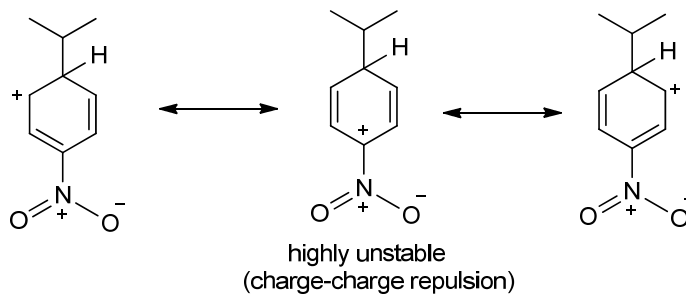

2) *Ortho* derivative

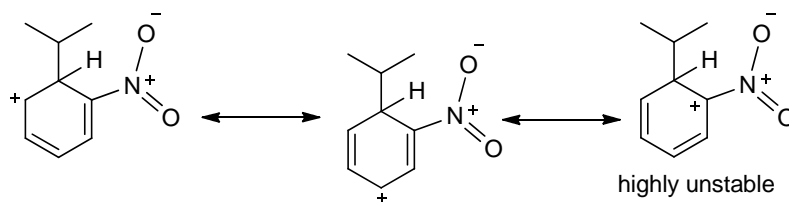

3) *Meta* derivative

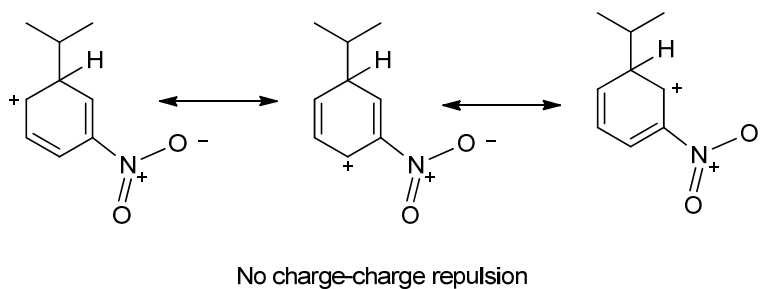

Stability of the *meta* intermediate is greater than that of the *ortho* and *para* intermediates. Therefore, the major nitroproduct is *meta*-nitrocumene if the synthesis is carried out from nitrobenzene.

Nitration of cumene, on the other hand, would yield *ortho*- and *para*-nitrocumene as predicted by the resonance structures of the intermediates:

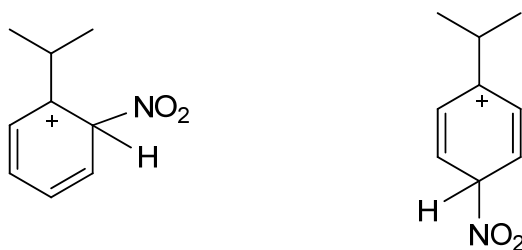

6.47

The rate of a chemical reaction is proportional to the concentration of the reacting molecules (section 6.11) as:



For reaction with cumene,  $k$  is larger than for reaction with benzene. However, if the benzene concentration is made large enough it can overcome the larger  $k$  for cumene, which would have caused more multialkylation.

6.48

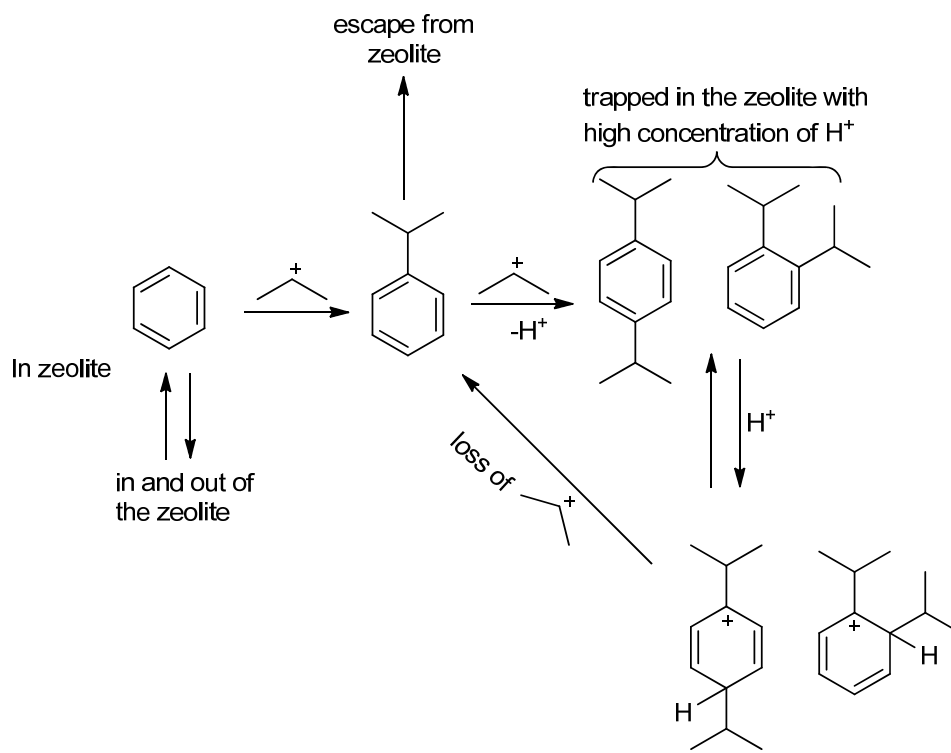

6.49

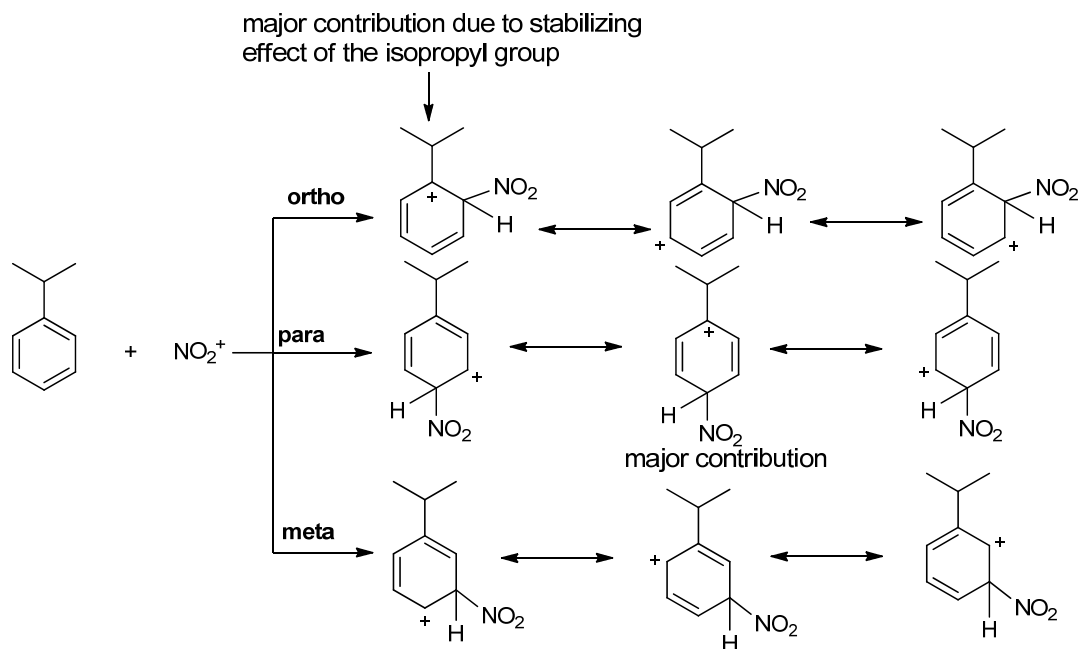

The carbocation intermediate is more stable in *ortho* / *para* addition than in *meta* due to the large contribution of the tertiary carbocation. Therefore, *ortho* / *para* substitution is favored.

1)

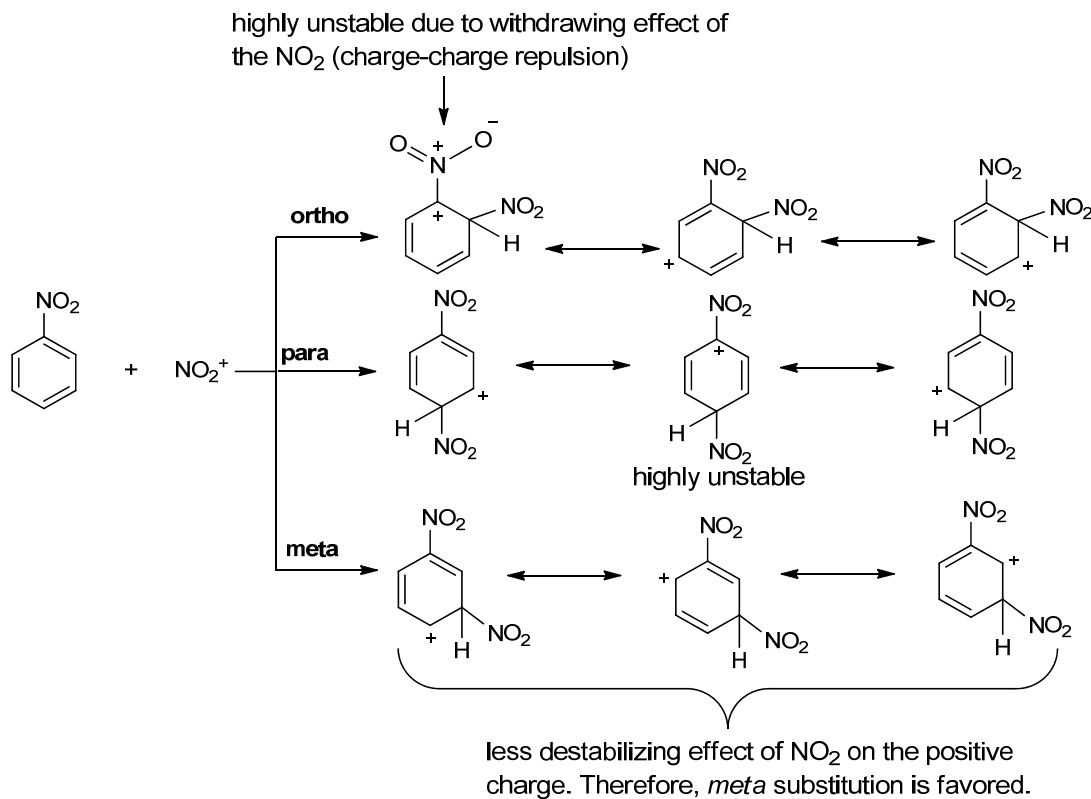

2) Same as reaction 1.

3)

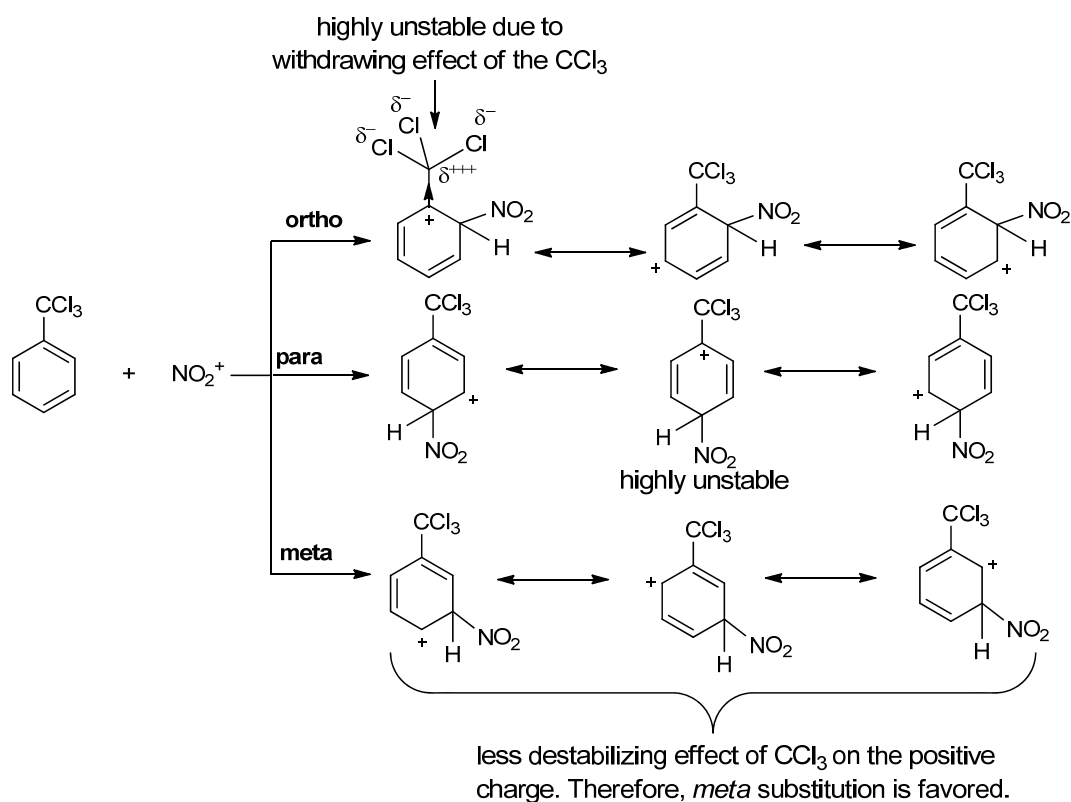

4) Same as in reaction 2

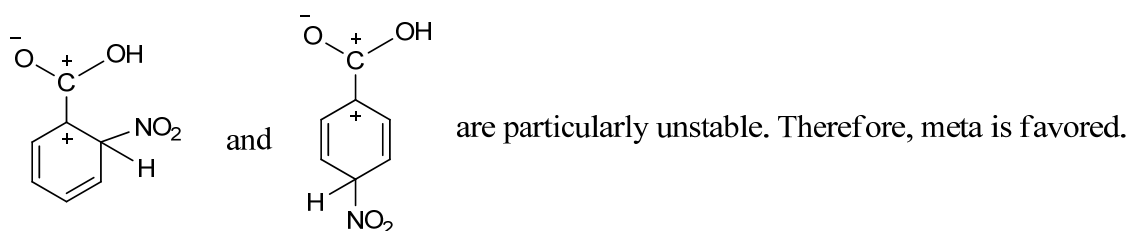

Note: Another way to solve this problem is to look at the electron density at the *ortho*, *para* and *meta*-positions of the starting aromatic compound instead of looking at the stability of the carbocation intermediate.

For example:

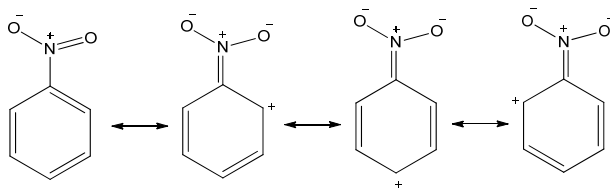

The resonance effect only decreases the electron density at the *ortho*- and *para*-positions. Hence these sites are less nucleophilic and so the system tends to react with electrophiles at the *meta*-position.

6.50

Isopropyl group is larger than methyl group and would generate steric strains with the *ortho*-substituents.

6.51

Isopropyl substituted cyclohexane favors the equatorial position more strongly in order to reduce the steric strains which strongly destabilize the axial-orientation. This is consistent with the experimental fact discussed in answer to problem 6.50.

6.52

$\text{NO}_2$ ,  $\text{CCl}_3$ ,  $\text{CO}_2\text{H}$  (deactivating groups) are electron withdrawing groups and would therefore decrease the electron density on the ring through resonance or inductive withdrawing effects; while *ortho/para*-directing substituents such as  $-\text{CH}_3$ , -isopropyl,  $-\text{NH}_2$ ,  $-\text{OH}$  are electron donating groups and would therefore increase the electron density on the ring (activating effect).

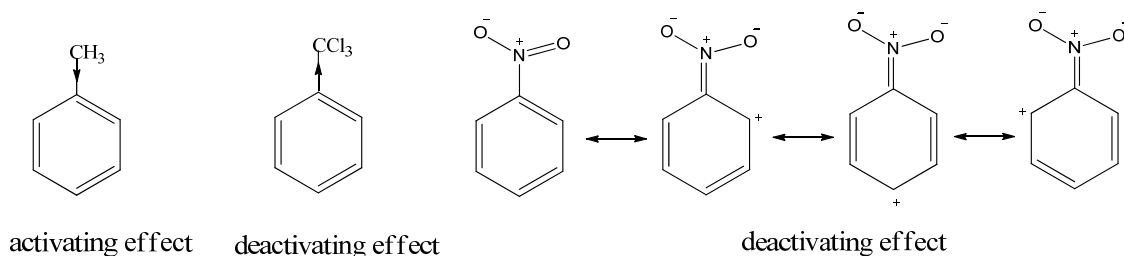

6.53

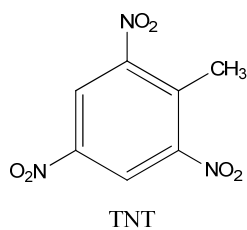

Trinitrotoluene (TNT) cannot be synthesized from nitrobenzene because  $-\text{NO}_2$  is a *meta*-directing group. It can indeed be made from toluene.

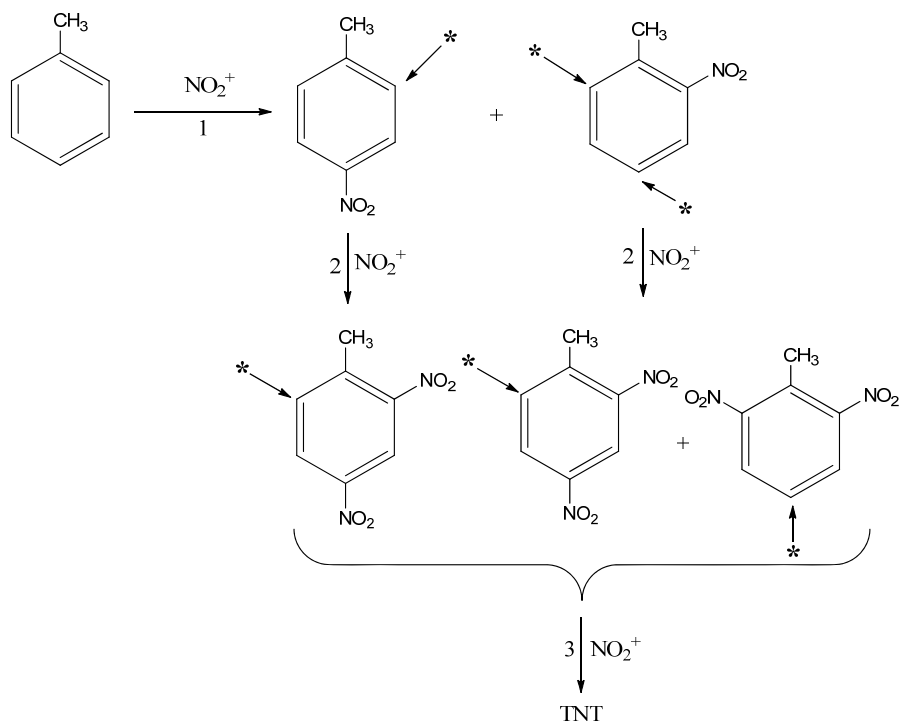

\* cooperating effects because  $\text{CH}_3$  is *ortho/para*-directing and  $\text{NO}_2$  is *meta*-directing.

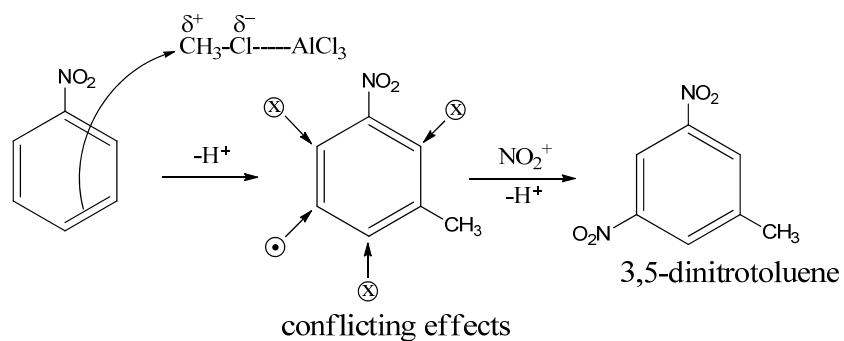

- ⊗ favored by  $\text{CH}_3$  and highly disfavored by  $\text{NO}_2$
- ⊙ disfavored by  $\text{CH}_3$  and highly favored by  $\text{NO}_2$

Insertion of the third  $-\text{NO}_2$  group is extremely difficult due to the large electron withdrawing effects of the two  $-\text{NO}_2$  which strongly decrease the electron density at 2-, 4- and 6-positions.

6.54

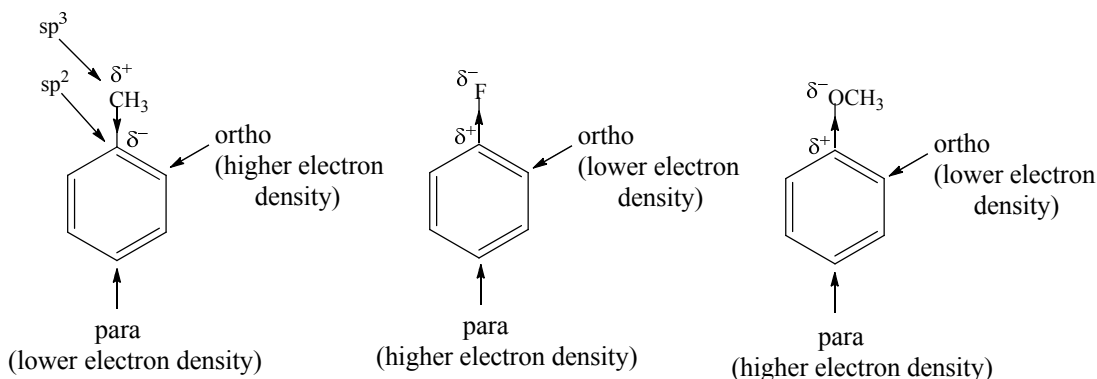

F and O are more electronegative than C, while  $sp^3$  hybridized carbon ( $CH_3$ ) is less electronegative than ring  $sp^2$  C (carbon atoms with larger proportion of s character are more electronegative because the s orbital is closer to the positively charged nucleus). As a result,  $-OCH_3$  and  $-F$  are electron withdrawing groups via an inductive effect, while  $-CH_3$  can be an electron donating group. Since inductive effects depend on the distance, the effect would be stronger in the *ortho* than in the *para* position. Therefore, toluene has more electron density at the *ortho* position than fluorobenzene and anisole.

The overall *ortho/para* directing effect of fluorobenzene and anisole arises from the importance of the following resonance structures:

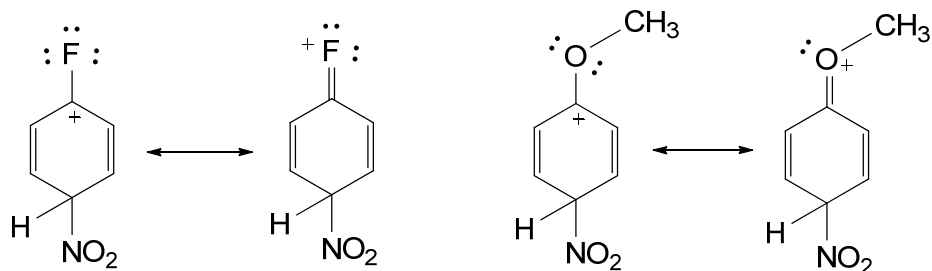

The inductive and resonance effects of F and  $OCH_3$  groups act in opposite directions.



## Chapter 7

### 7.1

The biological reason is that cell membranes composed of increasing proportion of unsaturated fatty acids remain fluid and can therefore act as gateways at lower temperatures than membranes composed of higher proportion of saturated fatty acids. Animals and plants operating at lower temperatures therefore require higher proportions of unsaturated fatty acids.

### 7.2

Yes. In most cases reported in Fig. 7.3, the proportions of unsaturated fatty acids are higher than those of saturated fatty acids for vegetables and fish compared to warm blooded animals.

### 7.3

Let's do it for three of the structures:

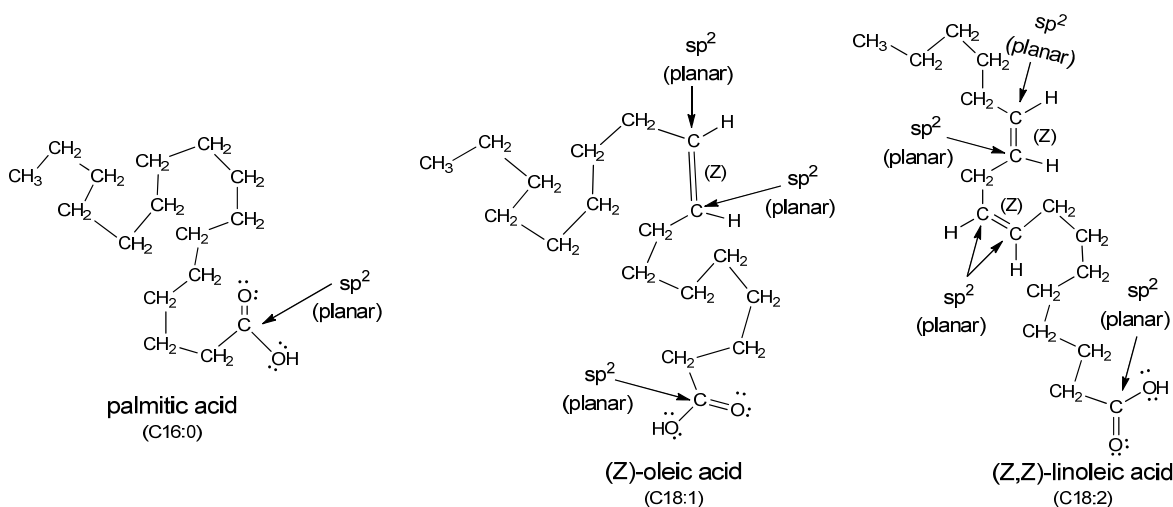

### 7.4

Fatty acid	N° Carbon atoms (n)	N° double bonds (m)
Palmitic acid	16	0
Stearic acid	18	0
Oleic acid	18	1
Linoleic acid	18	2
Lauric acid	12	0
Myristic acid	14	0

The general “structure code” of fatty acids is: **C<sub>n</sub>:m**  
 C = carbon atom; n= number of carbon atoms; m= number of double bonds

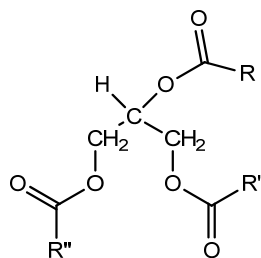

R, R', R'' can be identical or different

triglyceride  
ester of glycerol

The numbers in the table (Fig. 7.3) leave much unknown because these ratios of fatty acids may not correspond to single triglycerides but are averages of all triglyceride molecules. Therefore one is not able to predict the precise fatty acids in any one triglyceride molecule. Moreover, for some structures, enantiomers are possible, which would arise from substitution of different fatty acid ester groups at the two  $-\text{CH}_2\text{OH}$  groups in glycerol.

### 7.5

The two protons of  $\text{CH}_2$  groups are diastereotopic and the two  $\text{CH}_2\text{OH}$  groups are enantiotopic.

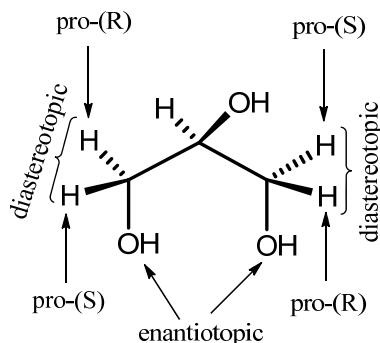

### 7.6



As will be discussed in section 11.3, while *trans* double bonds allow close packing, a *cis* double bond causes a chain shape that disrupt packing of the chains.

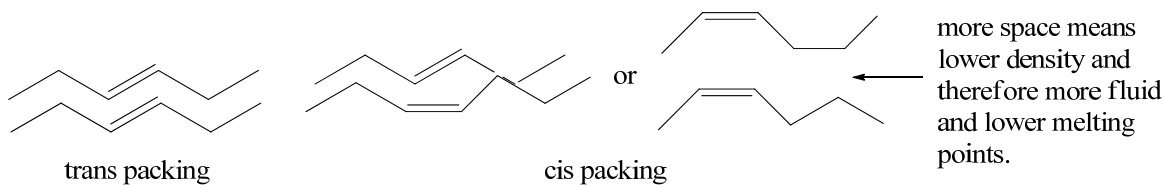

## 7.7

There are three -OH groups and four fatty acids. Taking into account the fact that glycerol has two equivalent -CH<sub>2</sub>OH groups, there are 40 possible combinations not counting enantiomers.

$$\begin{array}{rcl} \text{Total of combinations if all -OH different} & = 4^3 & = 64. \\ \text{Two equivalent -OH (e.g. PSO = POS, see below)} & = -6 \times 4 & = -24 \\ \text{Total} & & = 40 \end{array}$$

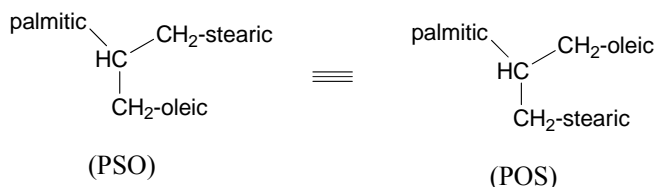

These two triglyceride molecules are equivalent

## 7.8

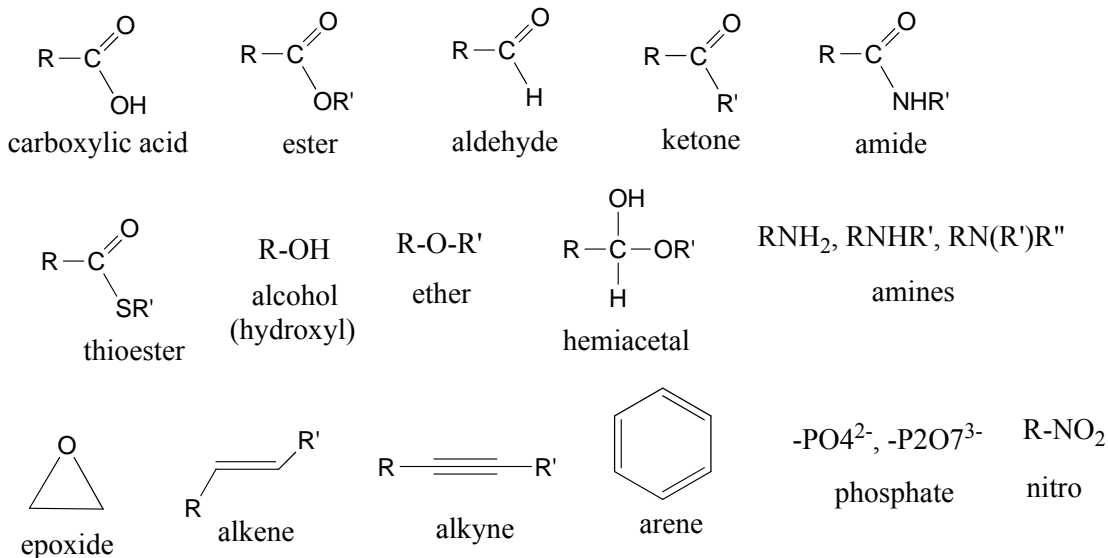

## 7.9

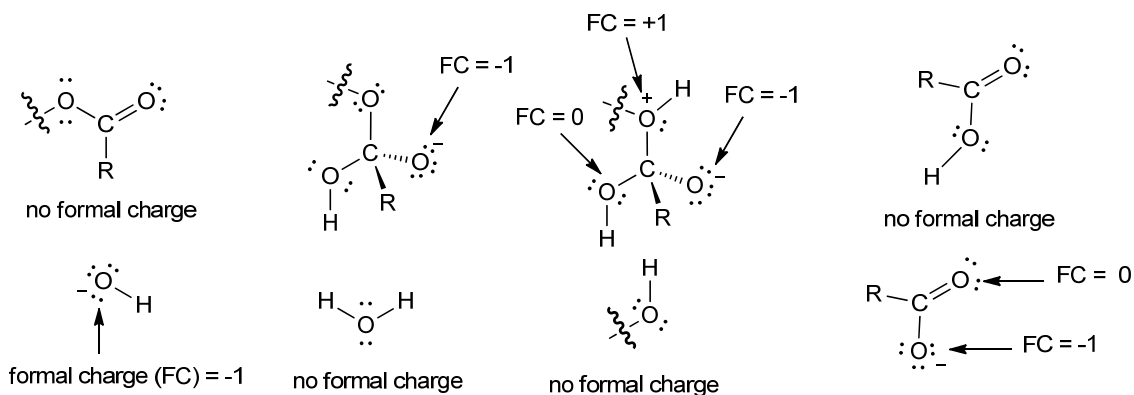

7.10

Because of the lack of amphiphilic character, which blocks the micelle formation necessary to form a soap.

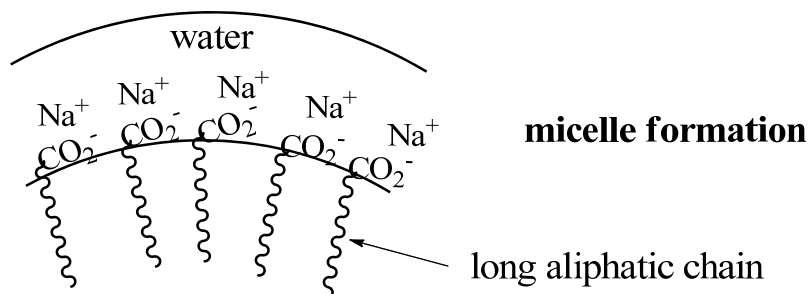

7.11

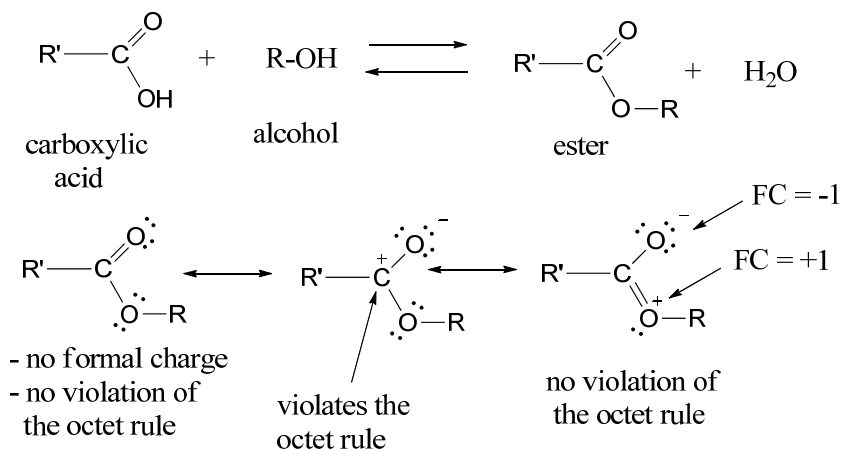

There is only one structure without formal charge which obeys the octet rule.

7.12

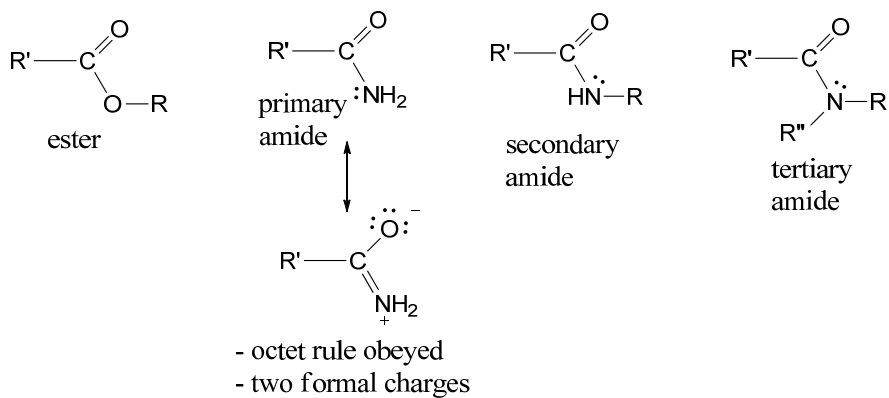

7.13

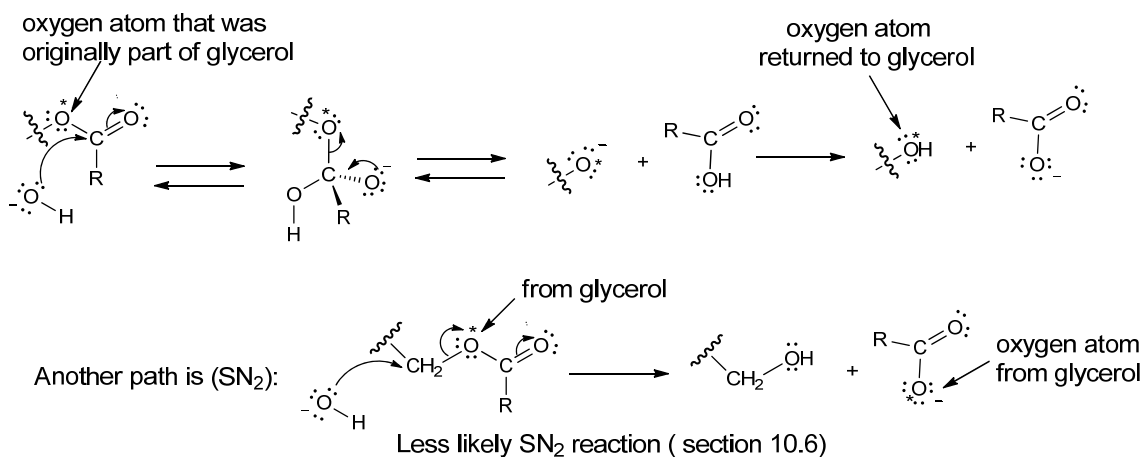

7.14

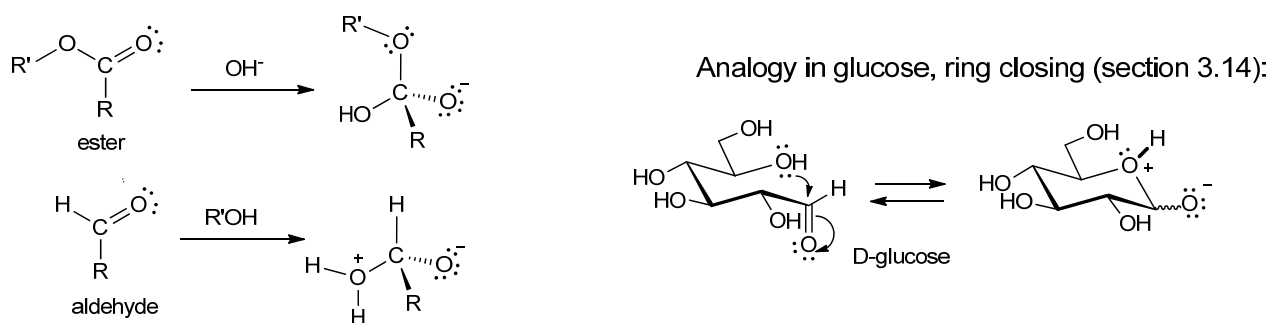

These are nucleophilic addition reactions to an electrophilic carbon atom of a carbonyl group

7.15

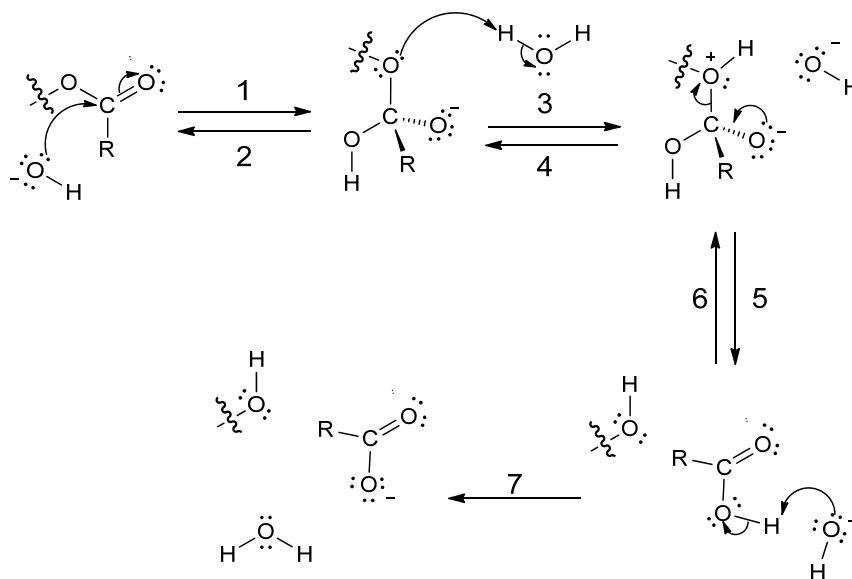

7.16

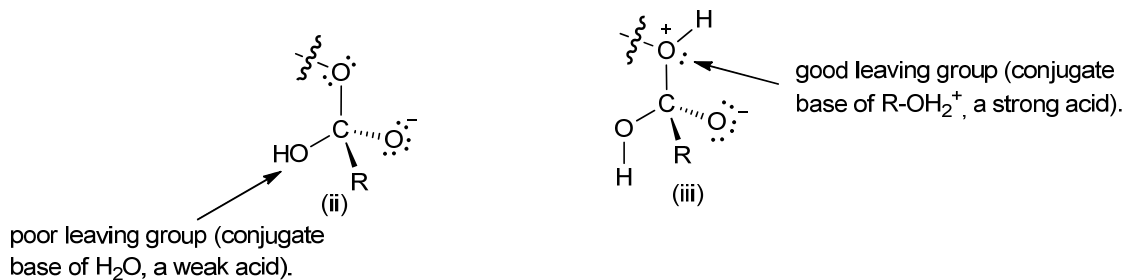

Reaction 2 is unlikely to occur while reaction 5 is more likely to occur. Reaction 3 sets up the leaving group necessary for reaction 5.

7.17

Reaction 7 is an acid-base reaction between a carboxylic acid (weak acid) and hydroxide anion ( $\text{OH}^-$ ), a strong base.

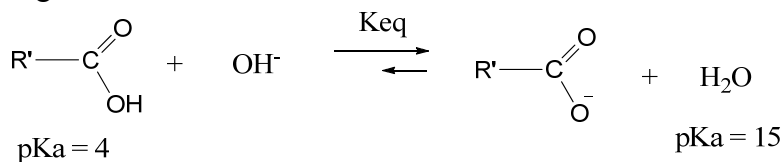

$K_{\text{eq}} \approx 10^{-4} / 10^{-15} \approx 10^{11} \gg 1$ . Therefore, The equilibrium is shifted to the product.

7.18

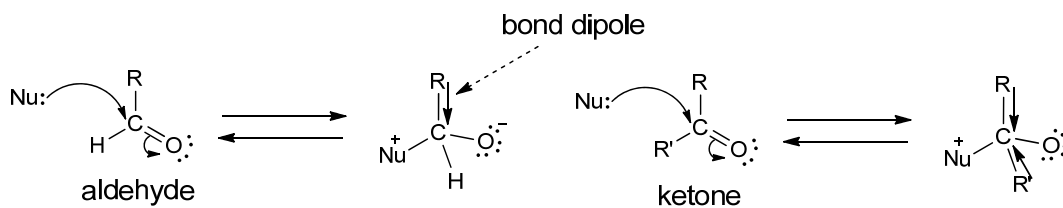

Ketones suffer from more steric strain than aldehydes due to interaction of the two alkyl groups ( $\text{R}$ ,  $\text{R}'$ ) after reaction with a nucleophile. In addition, the carbonyl group in a ketone is less reactive because of the stabilization by the two electron donating  $-\text{R}$  groups.

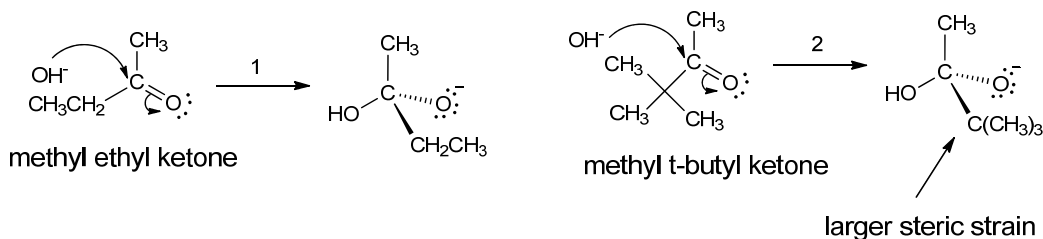

The bulky tertiary butyl ( $-\text{C}(\text{CH}_3)_3$ ) group causes a steric strain larger than that of ethyl group. Therefore, reaction 2 is slower than reaction 1.

7.19

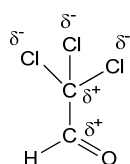
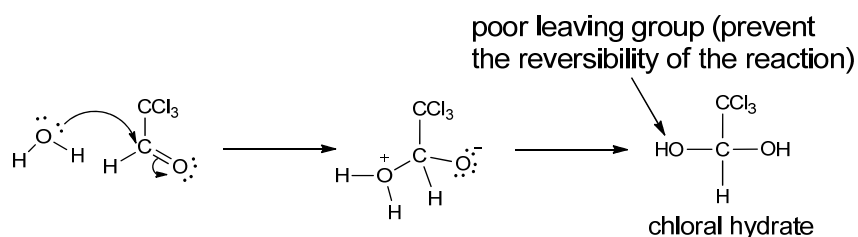

Partial positive charge repulsion from electronegativity differences leads to instability, which is relieved on reaction with water.

$-\text{CCl}_3$  is a strong electron withdrawing group and would therefore greatly increase the reactivity of the carbonyl group or put in another way, the carbonyl group is less stable because of dipole repulsion between electrophilic carbonyl carbon and electrophilic carbon bearing three chlorine atoms.

7.20

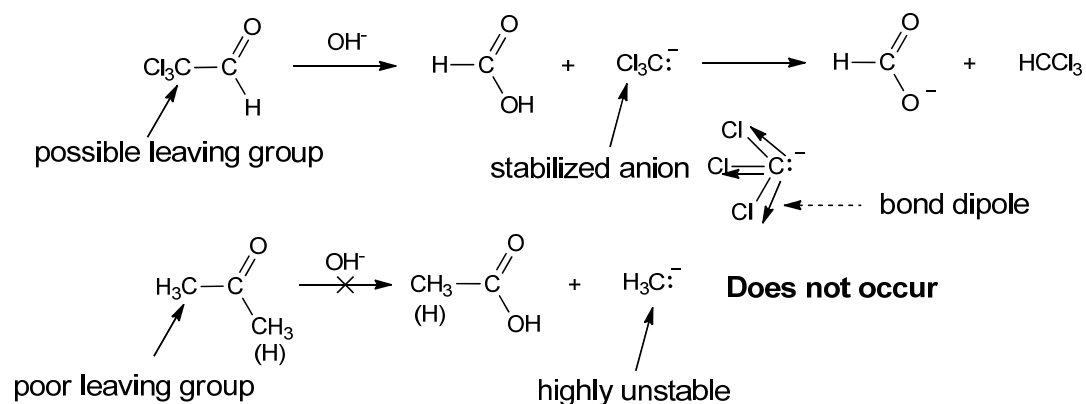

7.21

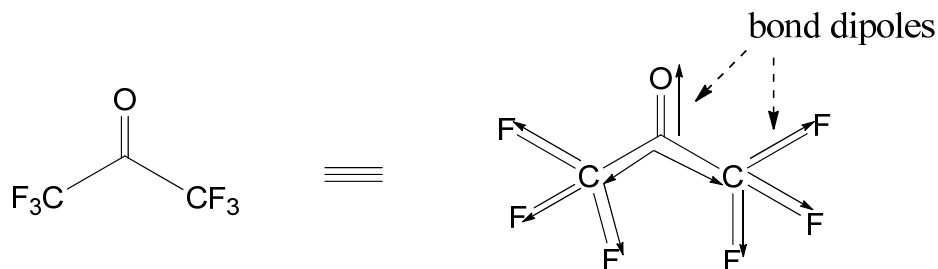

The high electronegativity of fluorine causes a dipole repulsion that destabilizes the ketone group, causing increased reactivity with a nucleophile such as  $\text{H}_2\text{O}$  to yield a hydrate.

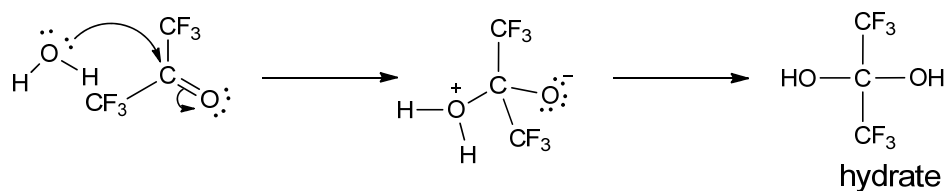

7.22

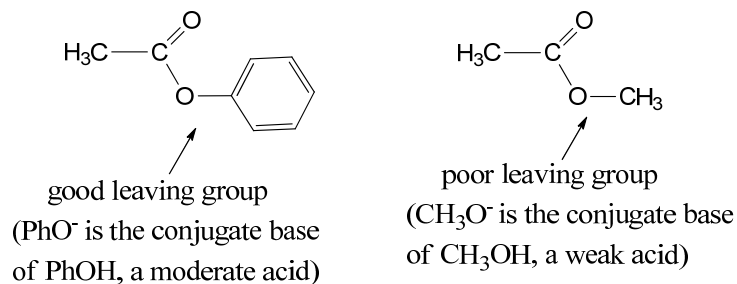

As a result the phenyl ester is more reactive than the methyl ester towards nucleophilic reactions.

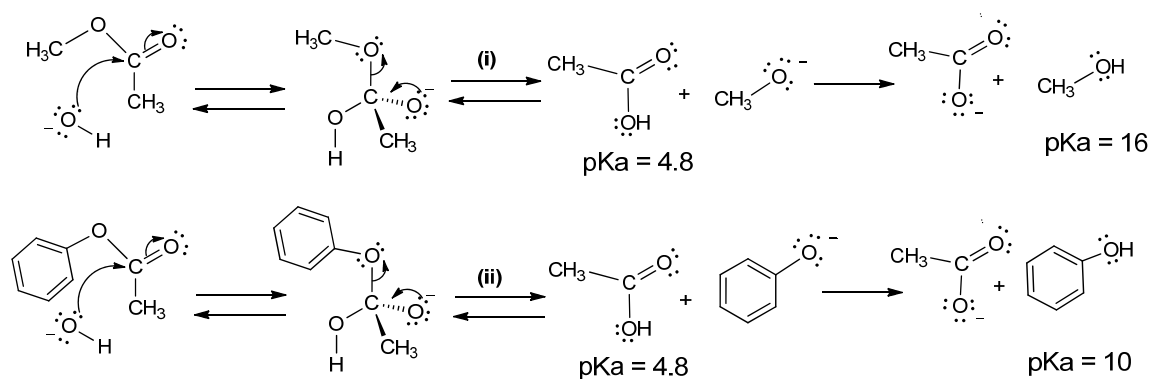

(ii) is faster than (i)

7.23

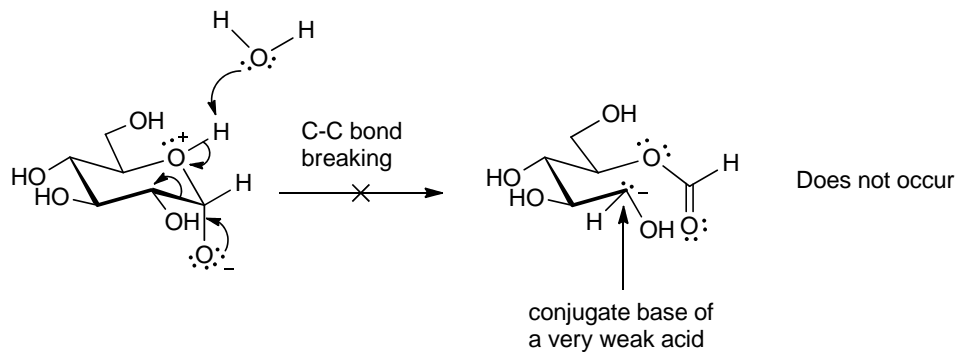



7.24

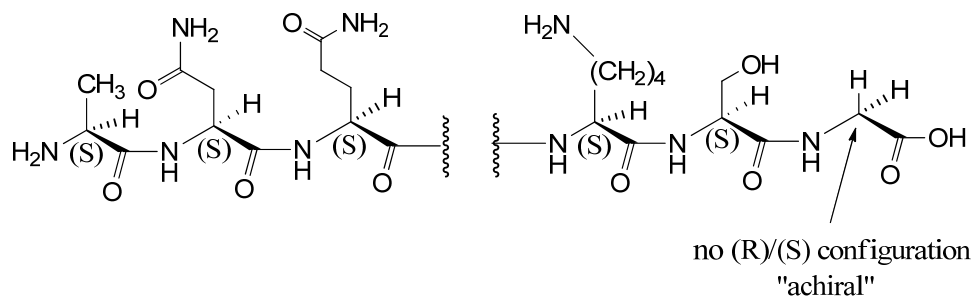

Except the glycine residue, which is not chiral, all other amino acids at the ends of lipase chain are of (S) configuration.

7.25

The two mechanisms differ in leaving group control.

Saponification (Fig.7.4)	Enzymatic process ( Fig.7.10 and 7.11)
Step1: Nucleophilic attack by OH <sup>-</sup> (reversible)	Step1: Acid-base reaction (within enzyme residues)
Step3: Acid-base reaction (reversible)	Step2: Nucleophilic attack
Step5: Elimination reaction (reversible)	Step3: transesterification
Step7: Acid-base reaction (irreversible)	Step4: Nucleophilic attack by H <sub>2</sub> O
	Step5: elimination (release of the fatty acid)

In step5 (enzymatic process), if the hydrogen bound to nitrogen in histidine were able to reach the OH group, the hydrolysis of the ester bond would be reversed.

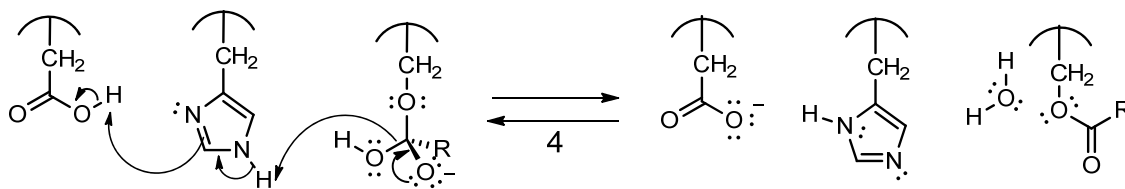

7.26

Reactions 1,3,4 and 5 justify this statement. In all these reactions, histidine is able to donate a proton to a glutamate unit (reactions 1 and 4) or to serine-triglyceride intermediate (reaction 3) or to serine-fatty acid intermediate (reaction 5); it also acts as a base by receiving a proton from serine (reaction 1), from glutamic acid (reactions 3 and 5) and from H<sub>2</sub>O (reaction 4).

7.27

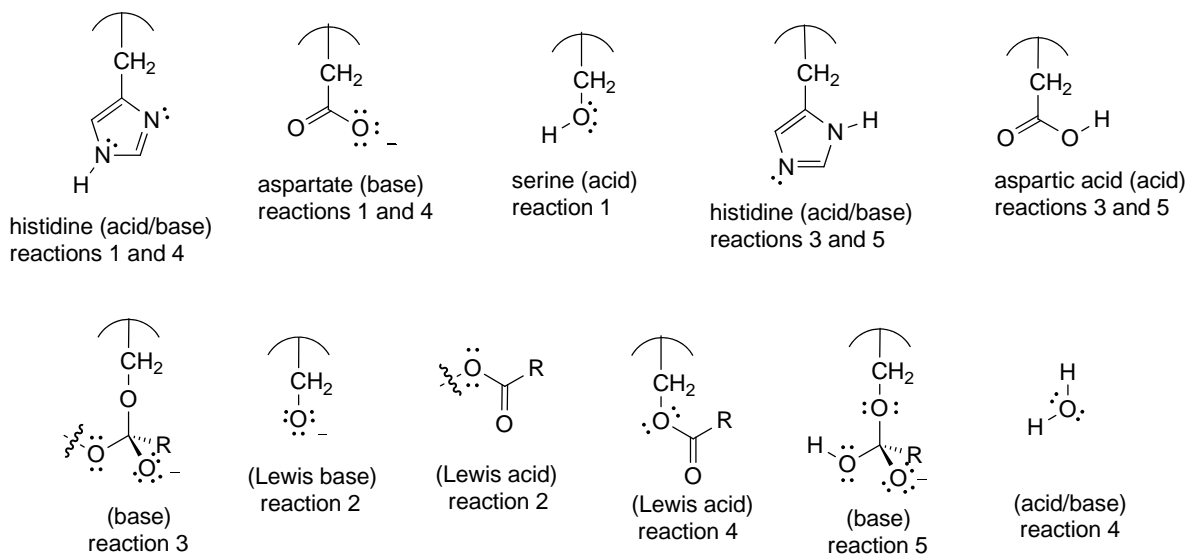

7.28

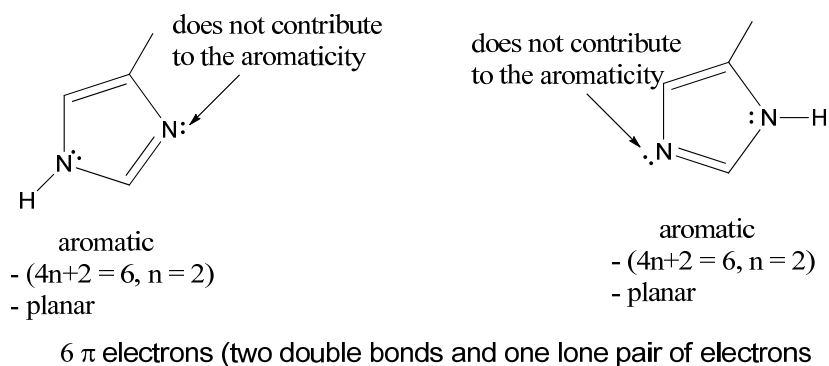

7.29

Let's do it for glycine, lysine and glutamic acid.

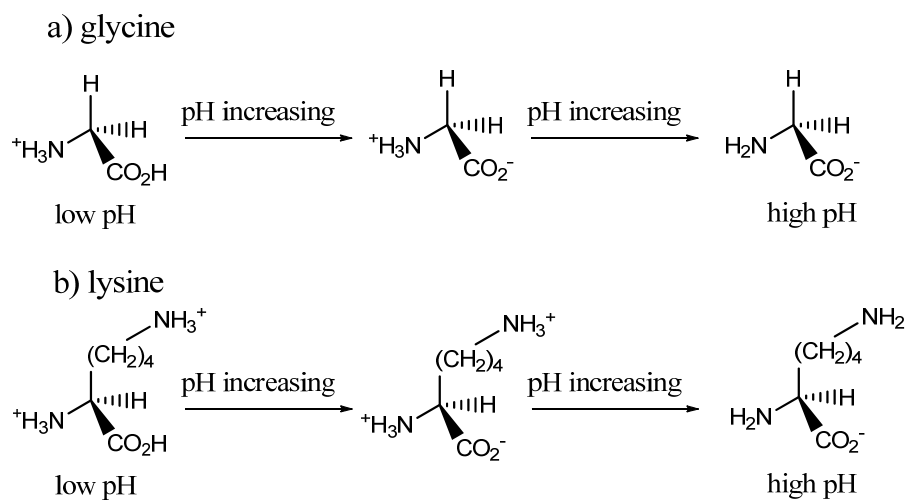

c) glutamic acid

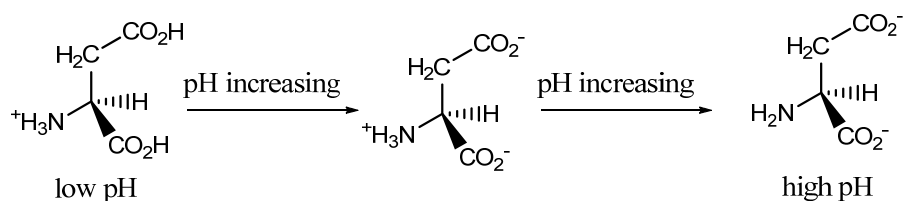

7.30

Phosphoric acid is a stronger acid than ethyl mercaptan( $\text{CH}_3\text{CH}_2\text{SH}$ ). Therefore the conjugate base of phosphoric acid is a weaker base than that of ethyl mercaptan ( $\text{CH}_3\text{CH}_2\text{S}^-$ ). As a result, the phosphate is the better leaving group, and therefore the thioester is formed as shown in Fig 7.17.

7.31

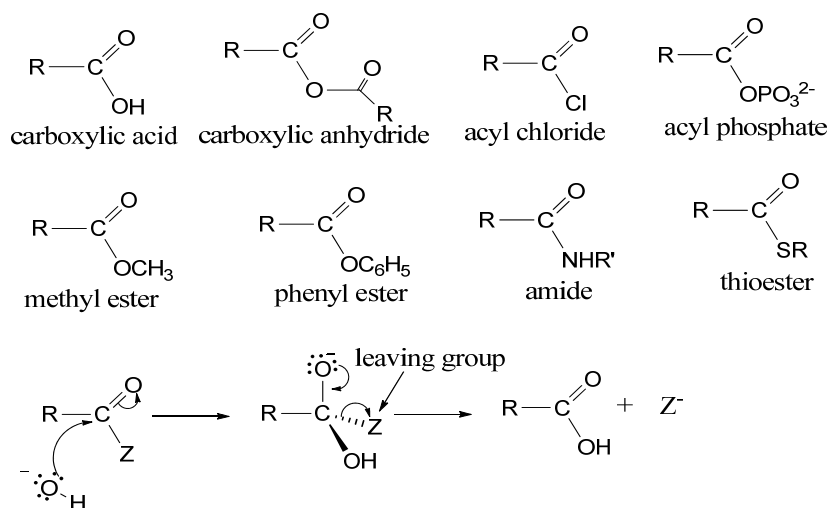

The reactivity of the intermediate strongly depends on the nature of the leaving group (Z):

- $\text{PO}_4^{3-}$  and  $\text{Cl}^-$  are excellent leaving groups (they are conjugate bases of very strong acids)
- $\text{RCOO}^-$  is a good leaving group (conjugate base of  $\text{RCOOH}$ , a moderate acid,  $\text{pK}_a \approx 4\text{-}5$ )
- $\text{RS}^-$  and  $\text{C}_6\text{H}_5\text{O}^-$  are moderate leaving groups ( $\text{RSH}$   $\text{pK}_a \approx 9\text{-}10$ ,  $\text{C}_6\text{H}_5\text{OH}$   $\text{pK}_a \approx 10$ )
- $\text{CH}_3\text{O}^-$  and  $\text{R}'\text{NH}^-$  are poor leaving groups (conjugate bases of very weak acids)

7.32

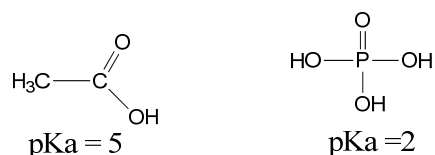

Phosphoric acid is a stronger acid than acetic acid. Therefore the conjugate base of phosphoric acid is a better leaving group than acetate ion (conjugate base of  $\text{CH}_3\text{COOH}$ ). Therefore the latter can displace the former in a nucleophilic substitution at the carbonyl group as in step2 of Fig. 7.16.

7.33

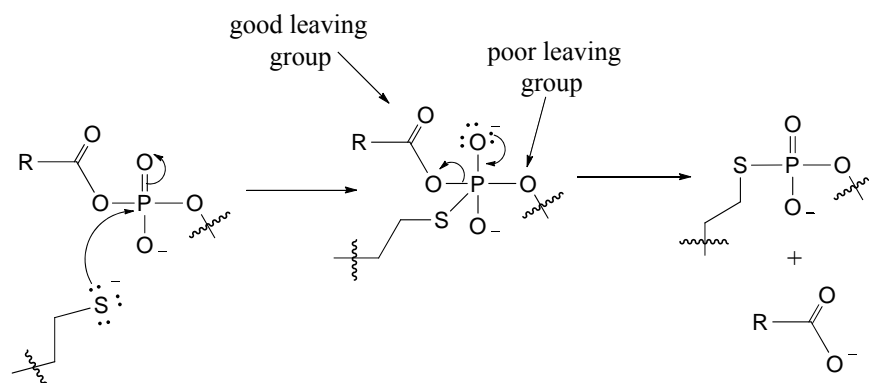

7.34

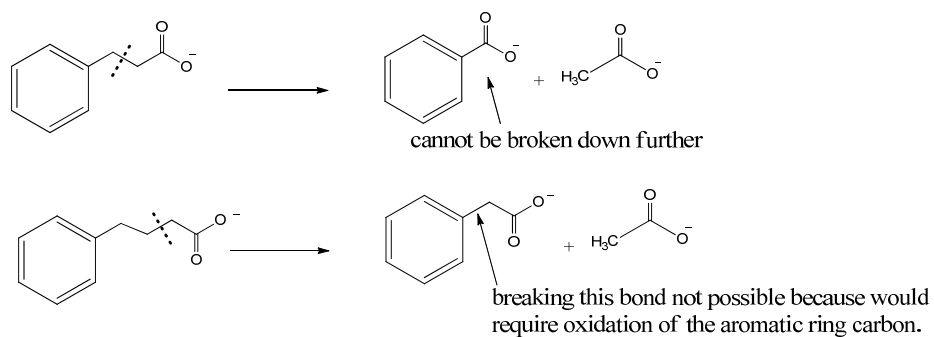

Therefore biological mechanism must be  $\beta$ -cleavage C-C as shown.

7.35

No answer required

7.36

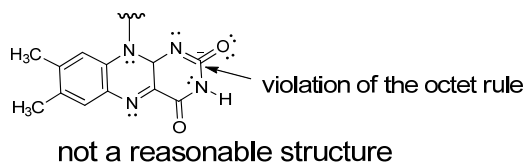
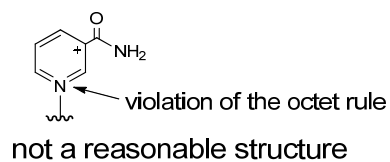
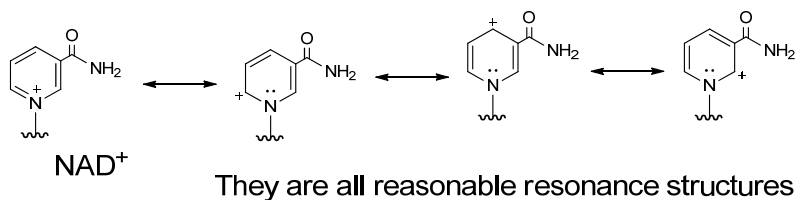
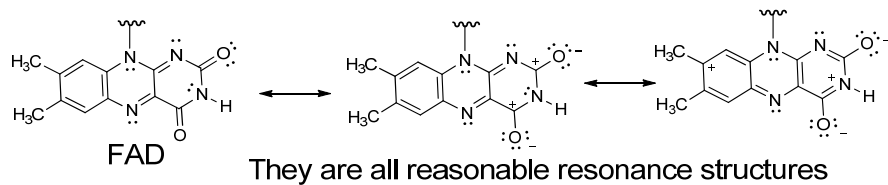

7.37

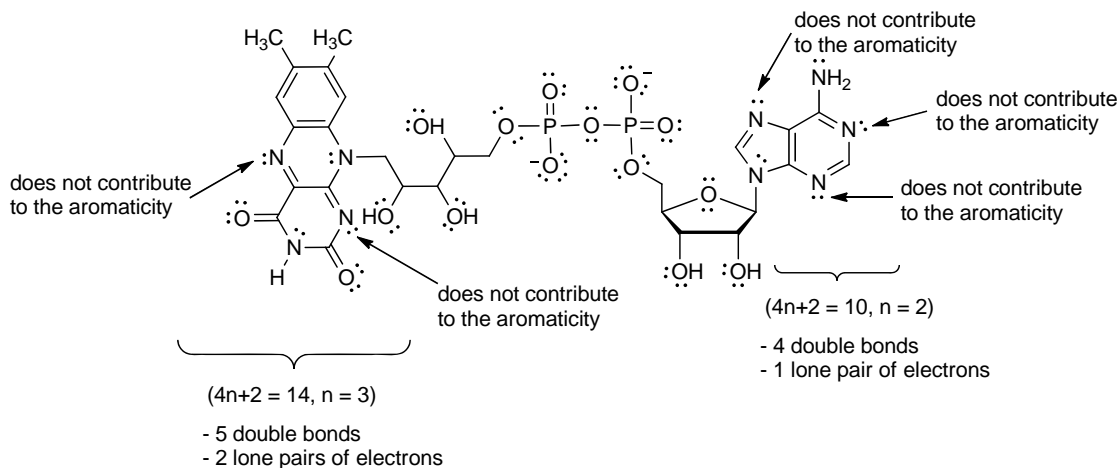

7.38

- a) Because this would result in an empty p-orbital on the carbon atom of the carbonyl group, which is conjugated to the  $\pi$ -system.

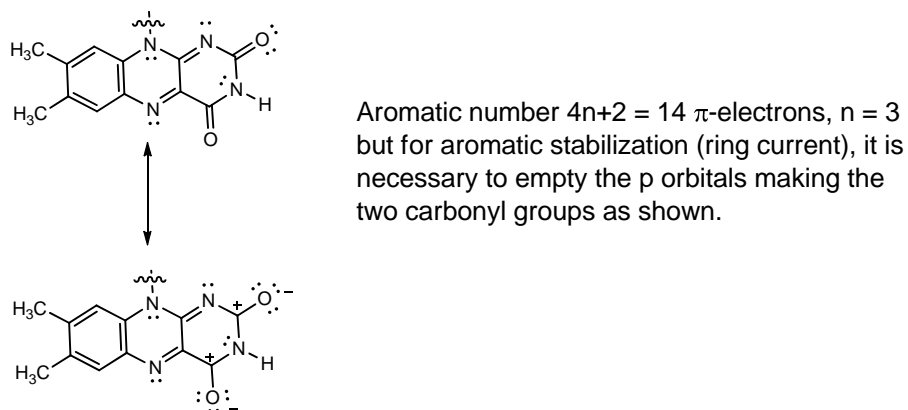

- b) Yes

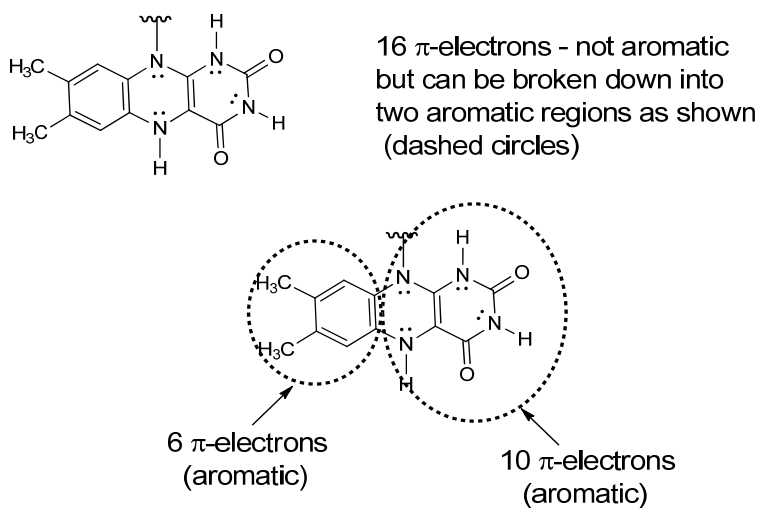

7.39

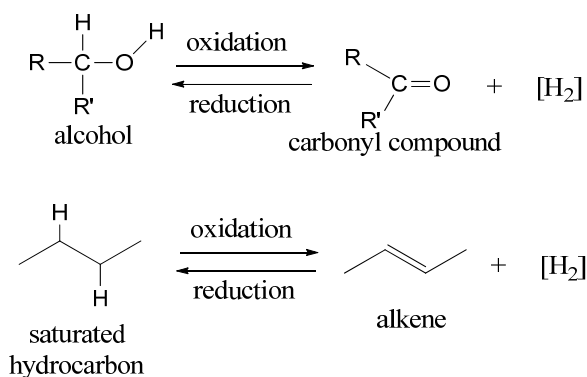

$[\text{H}_2]$  is not meant to be an actual reactant or product but rather a representation of the oxidation/reduction change.

7.40

In Figures 4.8 and 7.22, there is no “free” hydride ion. The hydrogen atom with two electrons is transferred from one bond to another.

7.41

They come from one of the two hydrogen atoms in the  $\alpha$ -position to the carbonyl group.

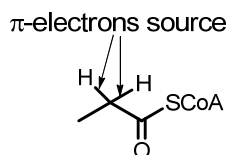

7.42

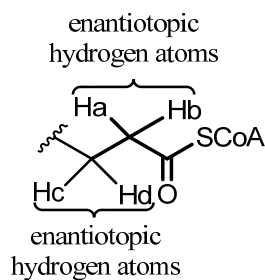

All possible enantiotopic choices are: (Ha, Hc), (Ha, Hd), (Hb, Hc), (Hb, Hd)

7.43

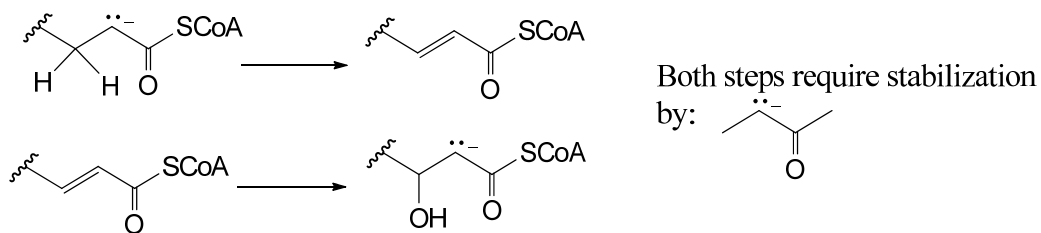

7.44

The following reactions involve stereochemical choices:

- 1- *Mechanism of the transformation of isopentenyl diphosphate to dimethylallyl diphosphate (Fig.5.9):* the two Hs on the carbon atom adjacent to the double bond in isopentenyl diphosphate, are enantiotopic. But this stereochemistry is lost in the subsequent reaction.
- 2- *Mechanism of the transformation of dimethylallyl diphosphate to geranyl diphosphate, then to farnesyl diphosphate (Fig. 5.12):* there are two hydrogen atoms in an enantiotopic relation which is lost in the subsequent elimination.
- 3- *Saponification (Fig.7.4):* both faces of a carbonyl group are enantiotopic. Therefore the intermediates (i) and (ii) are obtained as mixture of two stereoisomers (enantiomers). This stereochemistry is subsequently lost in reaction 5.
- 4- *Mechanism of enzymatic hydrolysis of triglycerides (Fig.7.10 and Fig.7.11):* both faces of the carbonyl group in steps 2 and 4, are enantiotopic (stereochemical choices). The stereochemistry is lost in steps 3 and 5
- 5- *Synthesis of fatty acyl CoA (Fig.7.17):* ( Same reason as above)

7.45

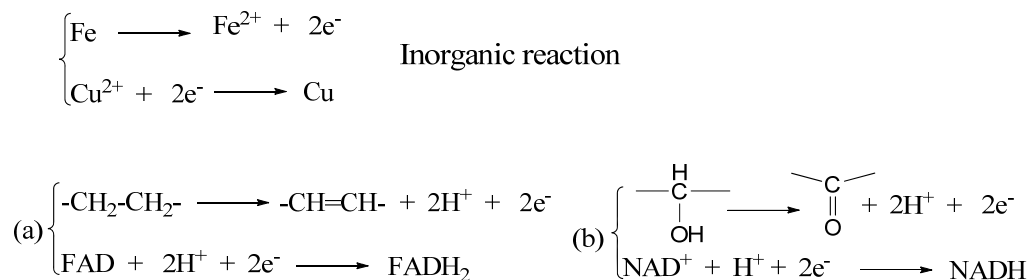

Both inorganic and biological examples involve transfer of electrons from the entities to be oxidized (Fe,  $-\text{CH}_2-\text{CH}_2-$ ,  $-\text{CH}(\text{OH})-$ ) to the oxidizers ( $\text{Cu}^{2+}$ , FAD,  $\text{NAD}^+$ ), which are therefore reduced.

7.46

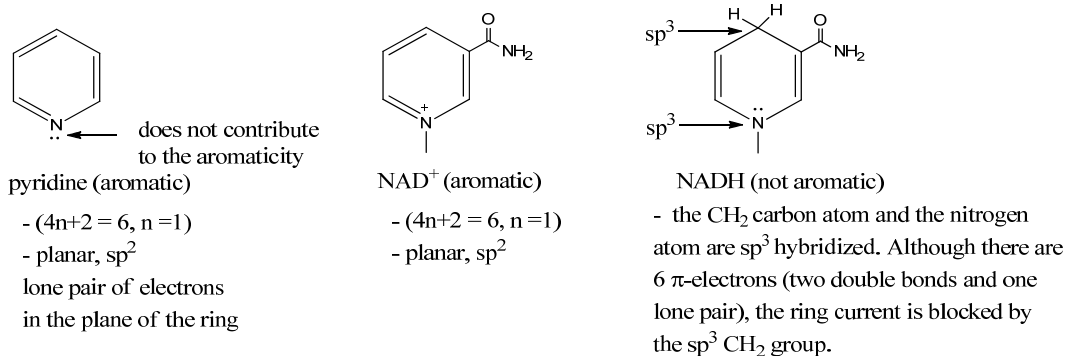

7.47

Glutamate and histidine units are neither oxidized nor reduced. They are only involved in Brønsted-Lowry acid-base reactions.

7.48

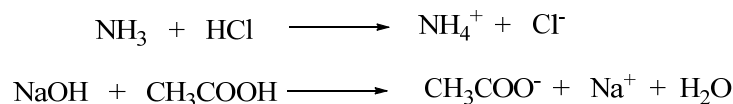

No. Because the protons and the electrons involvement occurs without variation of the oxidation numbers.

7.49

(a) No. Because the enzyme is specific for one configuration.

(b)

(i) The reaction would not occur for the same reason as above.

(ii) The reaction could not be catalyzed by the enantiomeric enzyme.

(iii) The reaction would occur because all reactants are uniformly enantiomeric.

7.50

$\text{NAD}^+$  is aromatic but destabilized by the formal charge (Fig. 7.24). FAD aromaticity requires the “disruption of the  $\pi$ -bonds” of the two  $\text{C}=\text{O}$  bonds (Fig. 7.20 resonance structures).

Benzene’s aromatic character does not carry any burden; all elements of the structure are “perfect”. Therefore benzene loses its aromatic character only with great difficulty.

7.51

Folding of the protein chain is necessary to bring the amino acids, which are not near to each other along the chain, into the close spatial relationship necessary to catalyze the reaction.

7.52

- Glutamate (Fig. 7.10 – step 1; Fig. 7.11 – step 4; Fig. 7.25): acts as Brønsted-Lowry base.
- Histidine (Fig 7.10 – step 1 and 3; Fig. 7.11– steps 4 and 5; Fig. 25): acts as Brønsted-Lowry acid and base.
- Glutamic acid (Fig. 7.10 – step 3; Fig. 7.11 – step 5): acts as Brønsted-Lowry acid
- Serine (Fig. 7.10 – step 1): acts as Brønsted-Lowry acid.
- $\beta$ -hydroxyl fatty acyl CoA (Fig. 7.25): acts as Brønsted-Lowry acid.
- Enzyme-triglyceride tetracoordinate intermediate (Fig. 7.10 – step 3): acts as Brønsted-Lowry base.
- Enzyme-fatty acyl tetracoordinate intermediate (Fig. 7.11 – step 5): acts as Brønsted-Lowry base.
- $\text{H}_2\text{O}$  (Fig. 7.11 – step 4): acts as Brønsted-Lowry acid.



7.53

Here is the answer for the molecules in Fig.7.27.

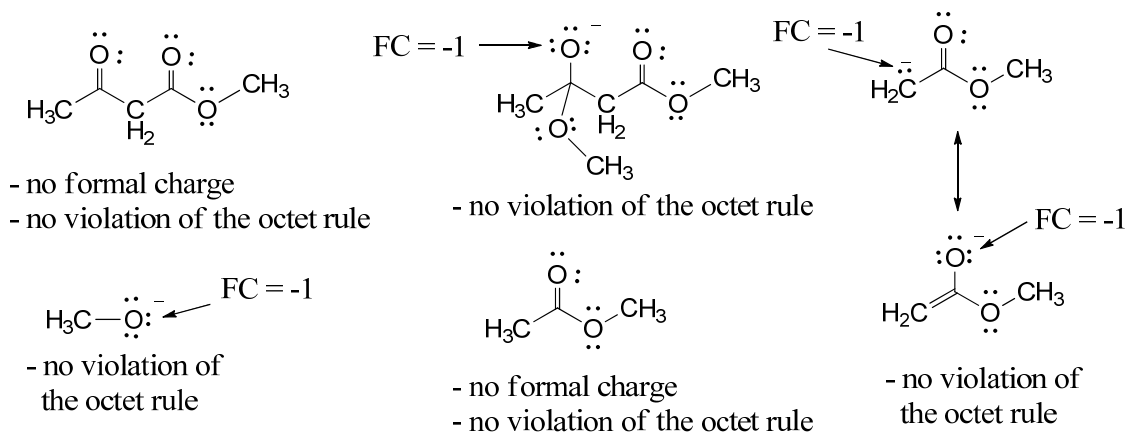

7.54

One of the functions of an enzyme is not only to lower the energy activation of a reaction but, in doing so, to choose one reaction over another when more than one reaction is possible.

The folded state of an enzyme is necessary for its selectivity, which works to block reactions 2 and 3 in Fig.7.26 by denying access to the necessary proton, which would lower the  $E_{\text{act}}$  of these steps.

7.55

The retro-claisen reaction of 1,3-dicarbonyl compounds gives an enolate (conjugate base of a C-H bond  $\alpha$  to a carbonyl group), which is stabilized by resonance.

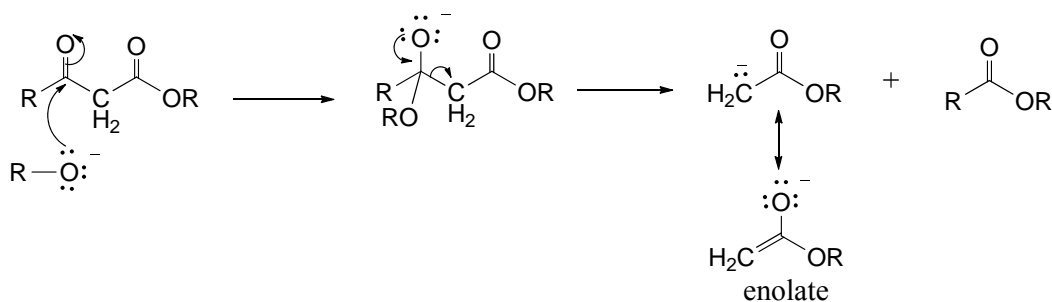

If the second carbonyl group were not present then:

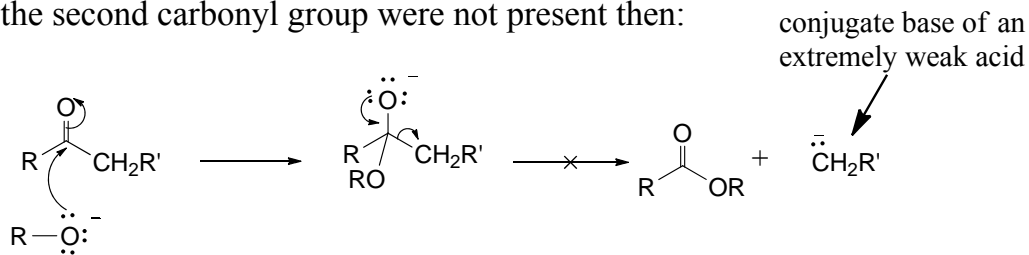

7.56

Carbanions of saturated hydrocarbons are poor leaving groups because they are the conjugate bases of very weak acids. Enolates are reasonable leaving groups because they are the conjugate bases of reasonable acids:

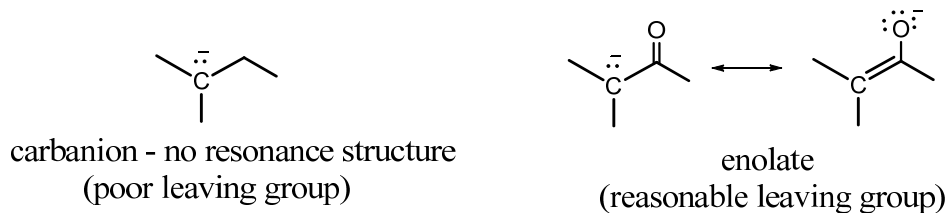

7.57

The first two steps of the catabolic process of the coenzyme A ester of a fatty acid involves a carbanion intermediate which can be easily obtained due to the acidity of the  $\alpha$ -protons.

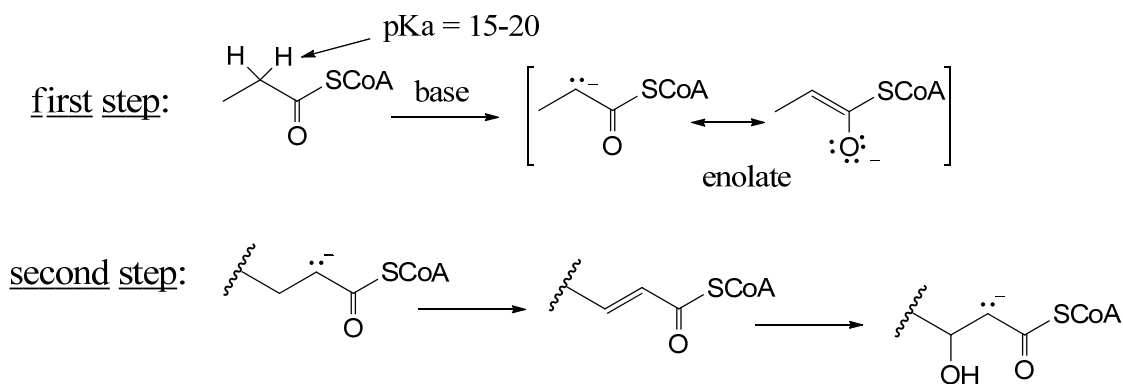

7.58

1) Esterification

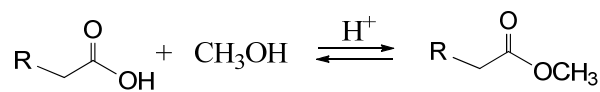

2) Enolate formation

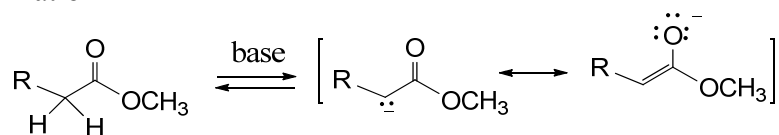

3) Claisen condensation

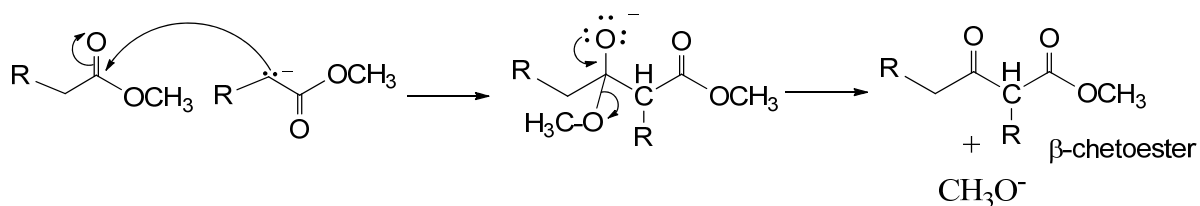

7.59

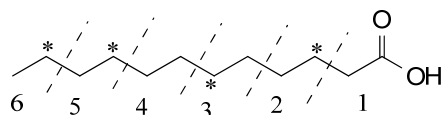

lauric acid

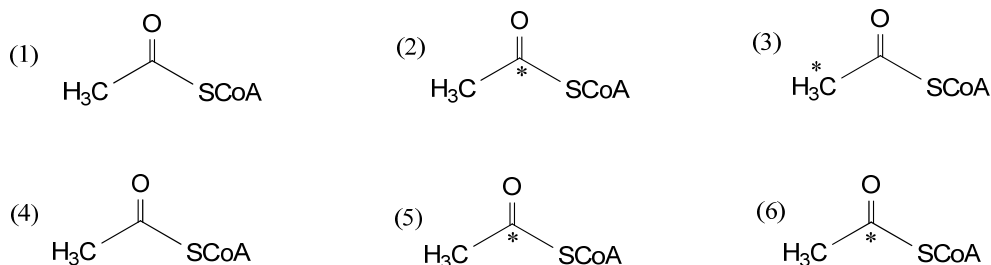

7.60

The reaction would have proceeded in the direction in which the cysteine unit is eliminated because thiolate ( $\text{R-S}^-$ ) is a better leaving group than enolate.



The  $\text{pK}_a$  of  $\text{R-SH}$  is lower (stronger acid) than the  $\text{pK}_a$  of a  $\text{C-H}$  bond adjacent to a carbonyl group. However, the cysteine unit of the enzyme delivers a proton to the carbonyl based leaving group thereby lowering the energy of activation ( $E_{\text{act}}$ ) for this path.

7.61

In Fig. 7.26, the enzymes play three roles. First, in irreversibly removing the proton from the cysteine unit of the protein allowing formation of intermediate **A**. Second and third, by blocking reactions 2 and 3, as shown in the figure, by not making protons available.

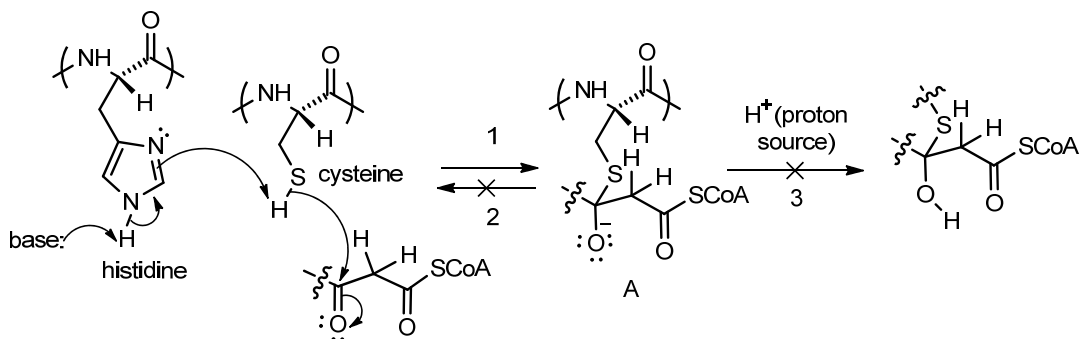

In Fig. 7.28, the enzyme supplies the necessary proton for the retro-Claisen reaction, which produces **C**. Here the enzyme does not block reactions but rather lowers the  $E_{\text{act}}$  of a critical step.

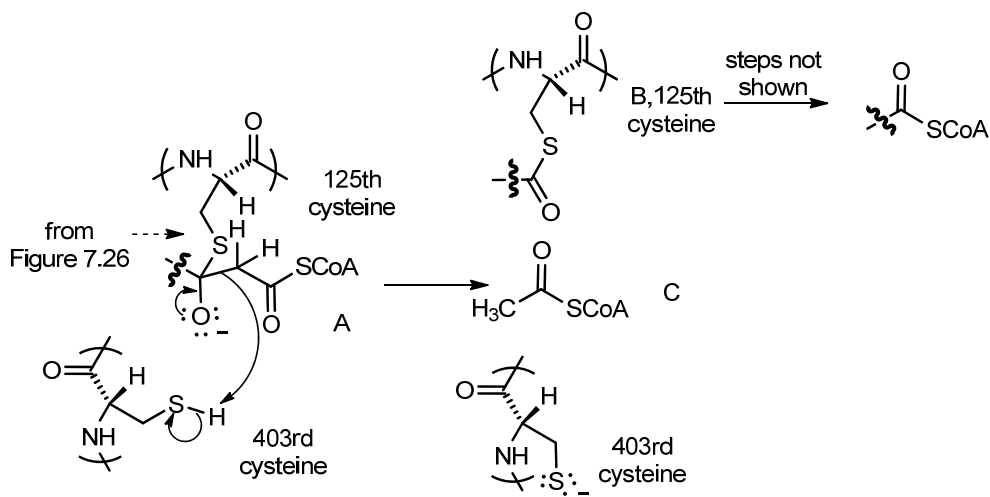

7.62

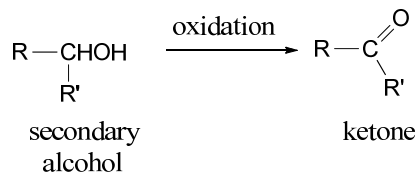
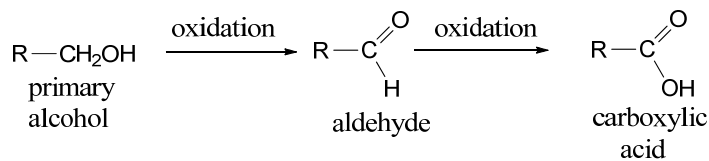
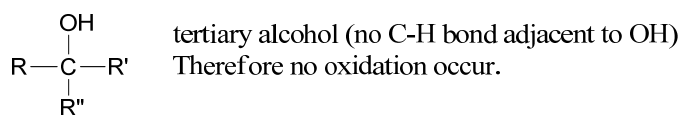
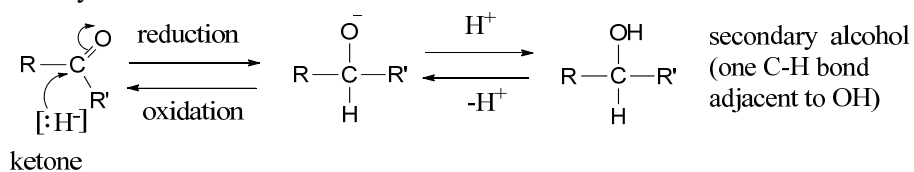
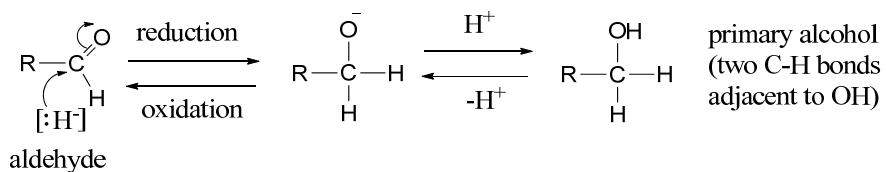

## Chapter 8

### 8.1

Let's do it for some of the structures.

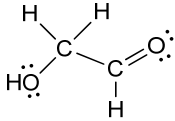

- No formal charge
- No violation of the octet rule

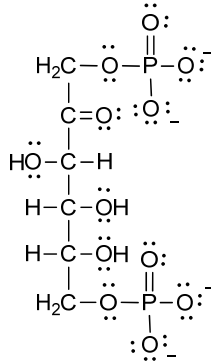

- Formal charges as shown
- Violation of the octet rule by the phosphorus atoms

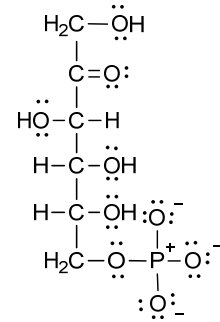

- Formal charges as shown
- Resonance structure: no violation of the octet rule but a formal  $\oplus$  charge on P

### 8.2

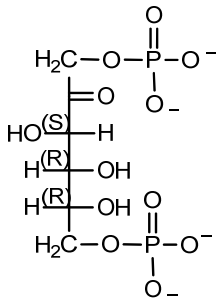

fructose-1,6-diphosphate

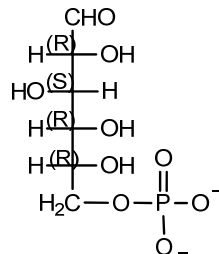

glucose-6-phosphate

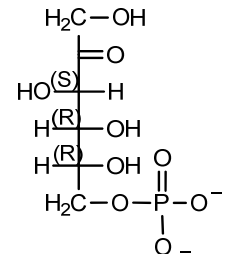

fructose-6-phosphate

### 8.3

Nature's problem with the catabolism of glucose is that the weakened carbon-carbon bond that would be broken is between C2 and C3, instead of C3 and C4. Therefore, the C2-C3 bond breaking would lead to formation of one "two carbon" and one "four carbon" molecule, which greatly complicates the chemistry that nature had to follow because instead of one kind of breakdown product there would be two to be dealt with. Therefore, it is necessary to isomerize glucose to fructose in order to accomplish a symmetrical breakdown of the six carbon atoms of glucose, that is breaking of the bond between C3 and C4.

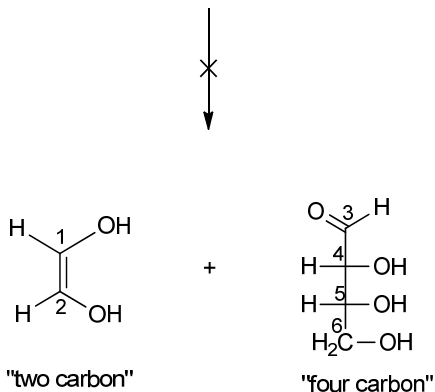
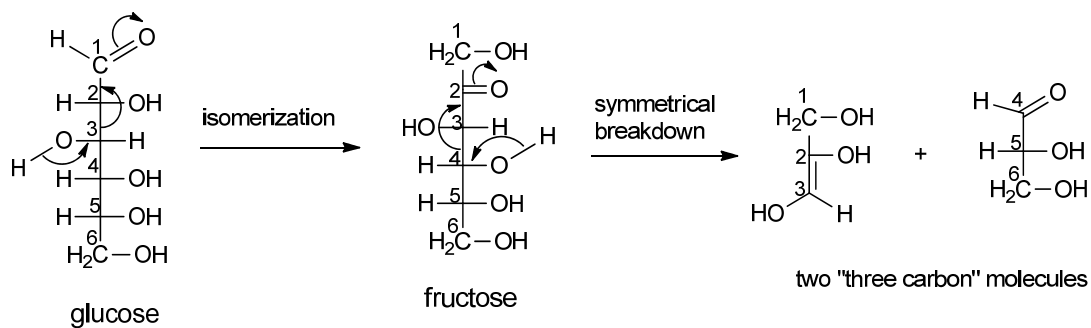

#### 8.4

The catabolism of a fatty acid and of glucose is driven by the weakness of a carbon-carbon bond  $\alpha$ - $\beta$  to a carbonyl group:

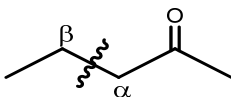

#### 8.5

In both catabolic processes (fatty acid and fructose), the C-C bond to be broken is  $\alpha$ - $\beta$  to a carbonyl group.

The tetracoordinate intermediate in the catabolism of fatty acid has a thioester group which could be ejected, which is not possible in the catabolism of fructose.

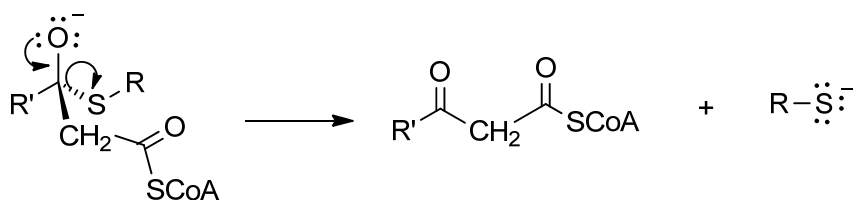

#### 8.6

Because unstable intermediates would form.

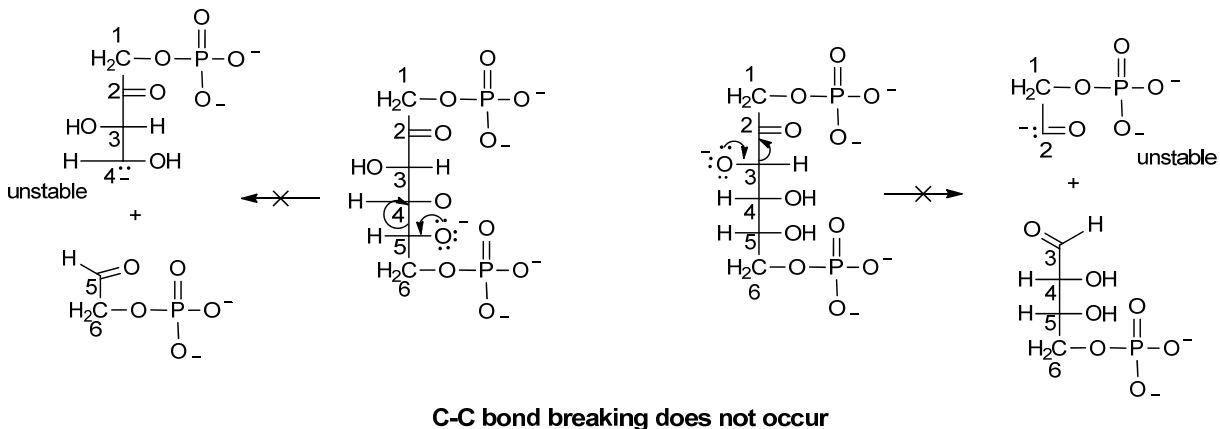

8.7

Possible sources of proton are:

- 1) the  $\text{-OH}$  group in formation of A in Fig. 8.4
- 2) a histidine or aspartic acid residue, as in Fig. 7.10.

8.8

The structure shown for C in figure 8.4 is only one of the resonance structures.

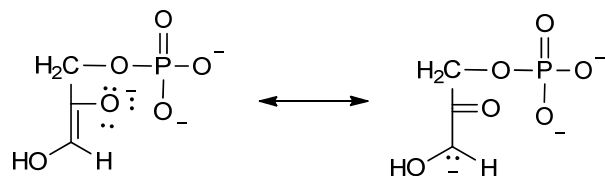

8.9

A molecule to be able to form an *enediol* intermediate, should have a hydroxyl group at the carbon atom  $\beta$  to a carbonyl group and should be able to form a carbanion at the  $\beta$ -position.

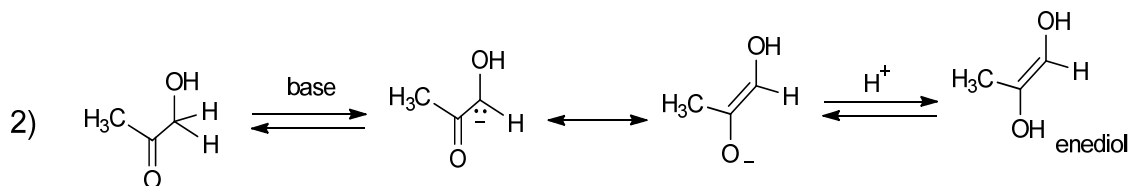
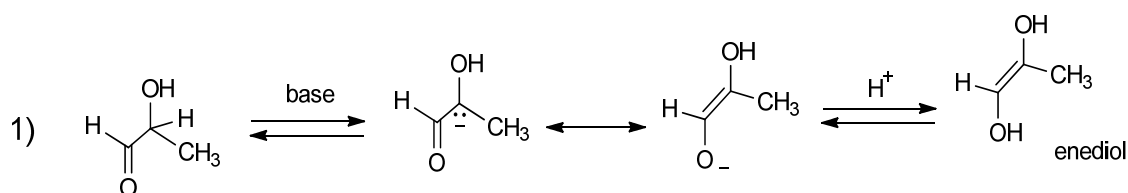

8.10

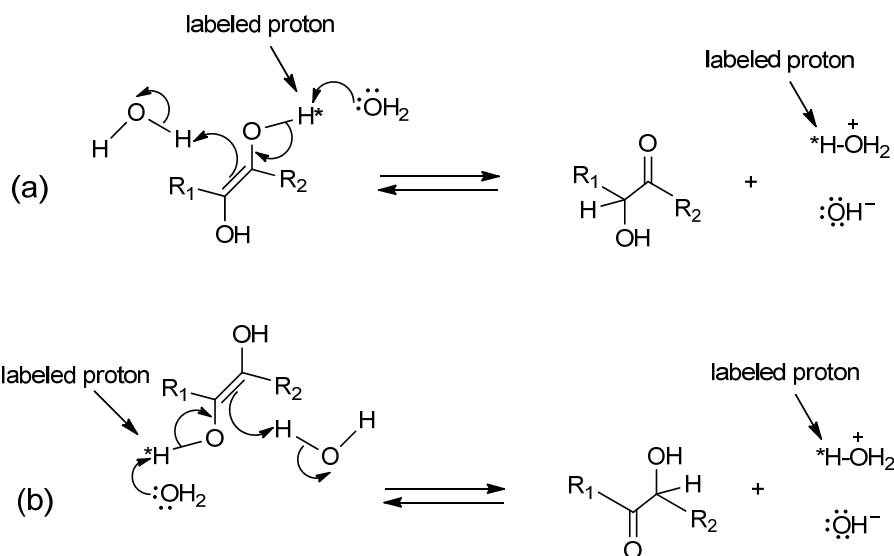

8.11

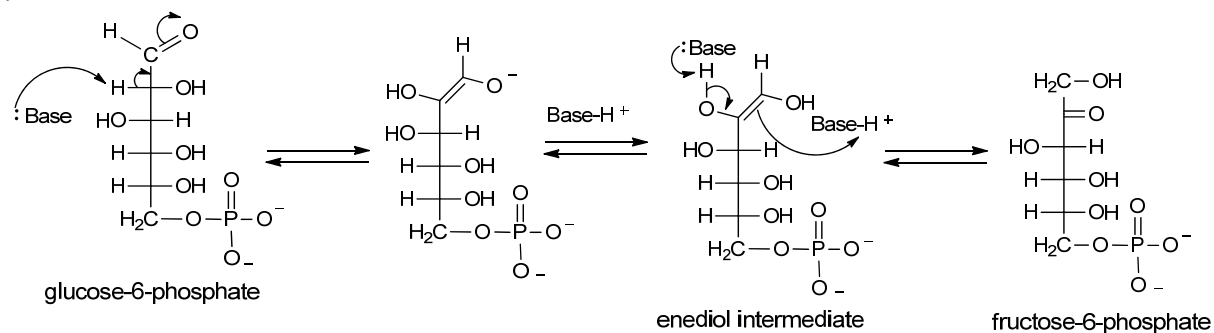

8.12

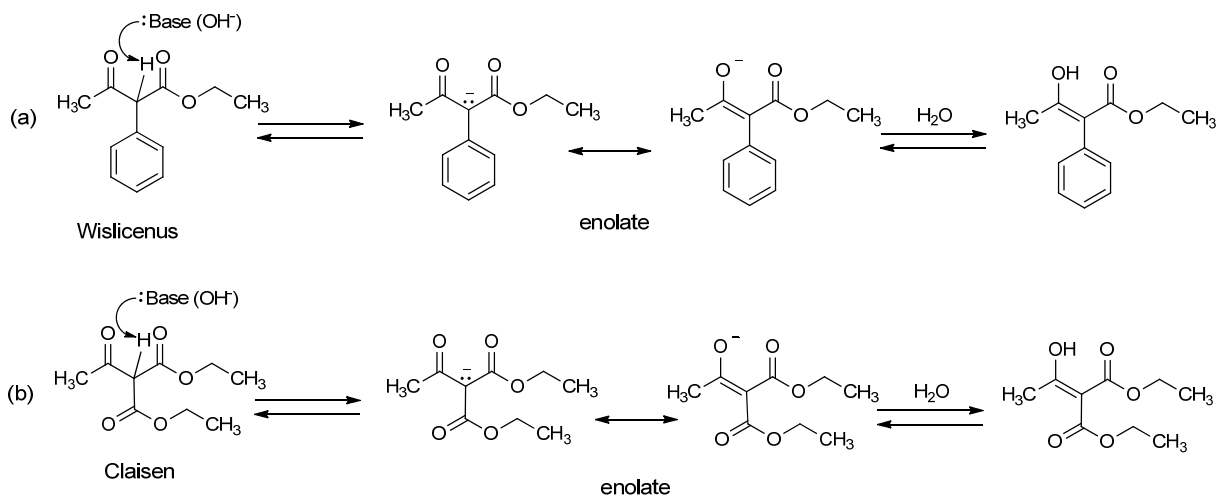

These reactions can also occur in acidic aqueous solutions.



8.13

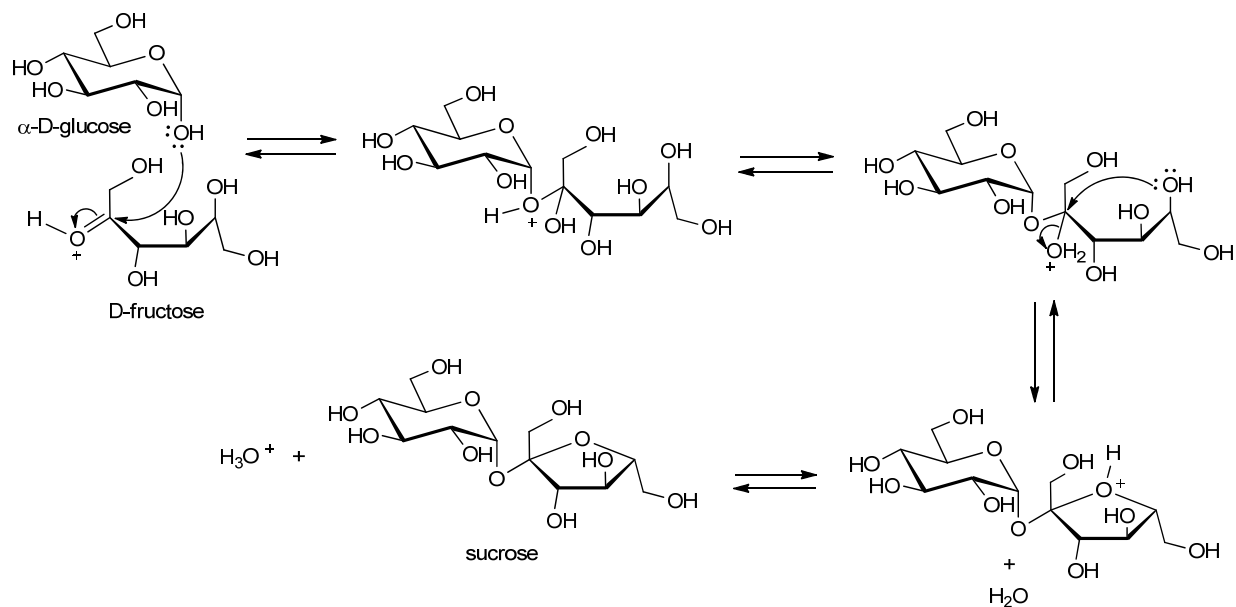

Yes. The first step is a nucleophilic attack of one of the OH groups of  $\alpha$ -D-glucose at the ketone carbonyl of D-fructose in presence of  $\text{H}^+$  as catalyst.

8.14

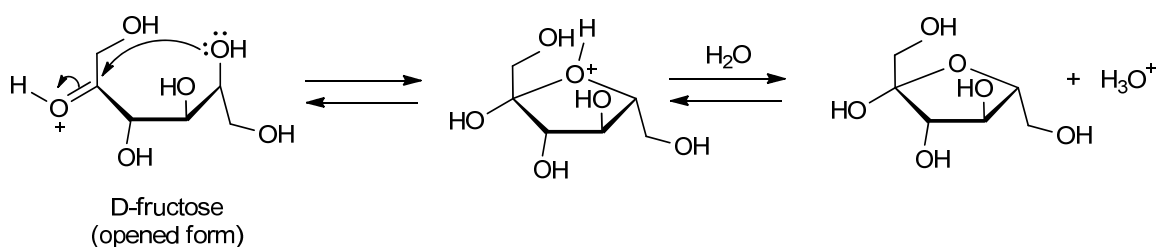

Yes. The first step is an acid-catalyzed intramolecular nucleophilic attack of the OH group at the ketone carbonyl.

8.15

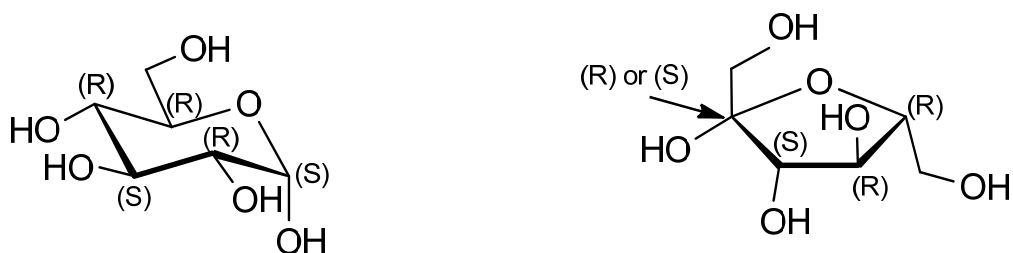

8.16

Tautomeric isomers are structural isomers (interconvertible through bond breaking) and differ in the point of attachment of a hydrogen atom, while conformational isomers have the same connection between atoms and are interconvertible only through torsional motions (no bond breaking).

8.17

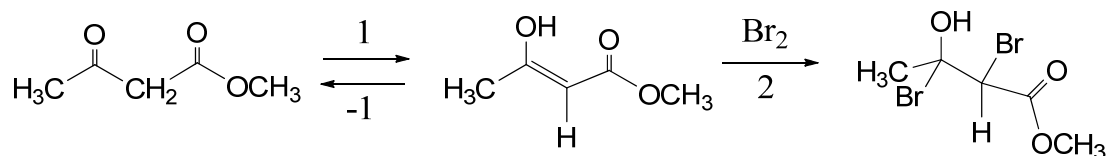

The irreversible step 2 causes, by Lechatelier's principle, all starting material to form the enol.

8.18

Compared to reaction 1, in reaction 2 the enol form is partially stabilized by H-bonding between -OH and the nearby carbonyl group

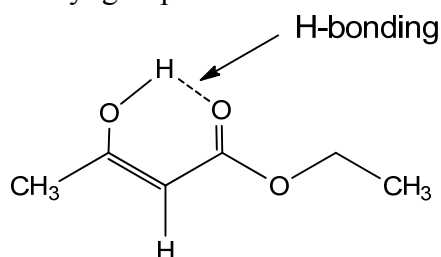

Reaction 3: the proportion of enol increases (compared to reaction 2) because of conjugation with the aromatic system.

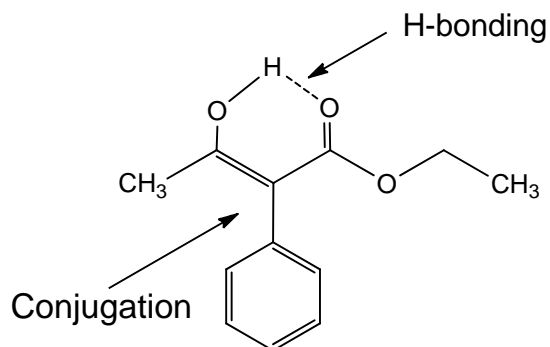

Reaction 4: in organic solvents, the enol form is favored due to H-bonding stabilization (see reaction 2), while water (hydrogen bonding solvent) makes the lone pairs of the carbonyl oxygen atom less available for intramolecular bonding, shifting the equilibrium to the left.

Reaction 5: phenol (enol form) is more favored than its keto form due to aromatic stabilization. Note that phenol is aromatic while the keto form is not.

8.19

Let's do it for two of these reactions.

Reaction 1:

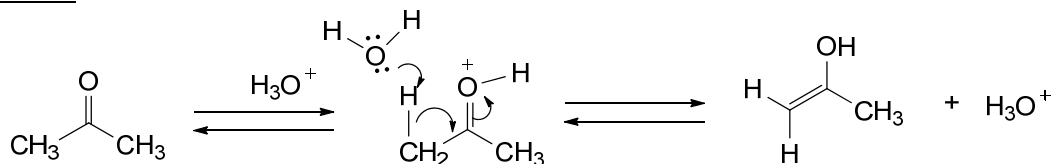

Reaction 5:

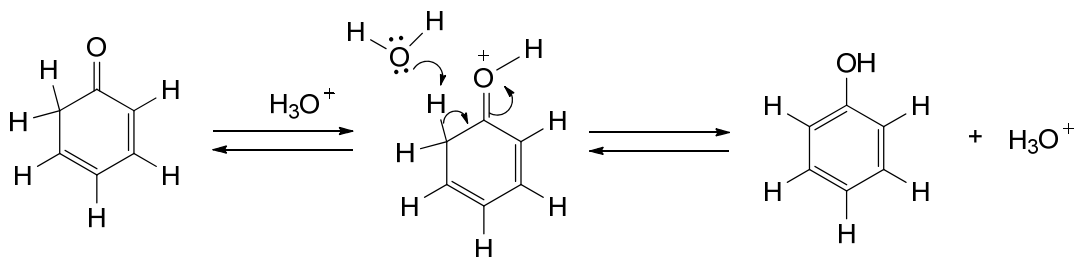

8.20

Resonance structures are obtained through electron shifts while isomers differ in the position of atoms (shift of atoms and electrons).

8.21

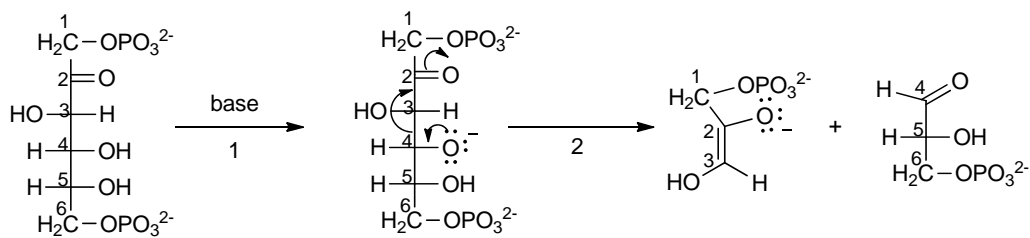
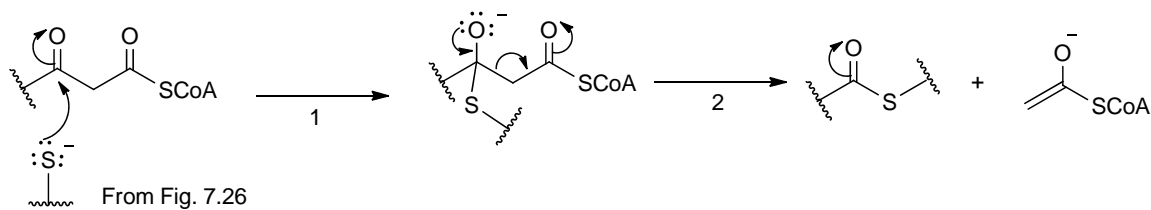

Steps 2 in each mechanism, but not steps 1 have the same driving force.

8.22

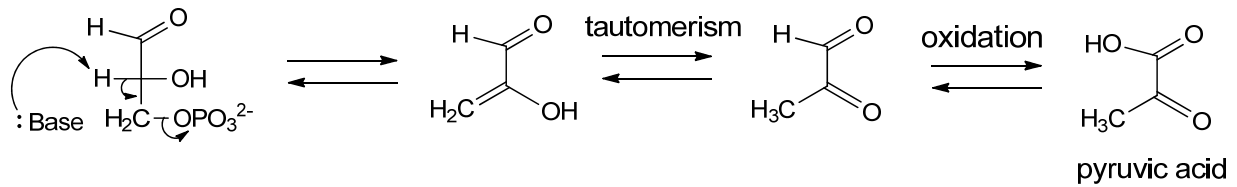

A coenzyme for oxidation (e.g.  $\text{NAD}^+$ ) is necessary to convert the aldehyde group to a carboxylic acid.

8.23

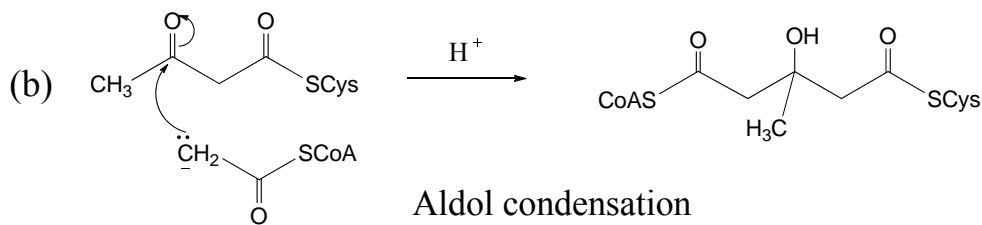
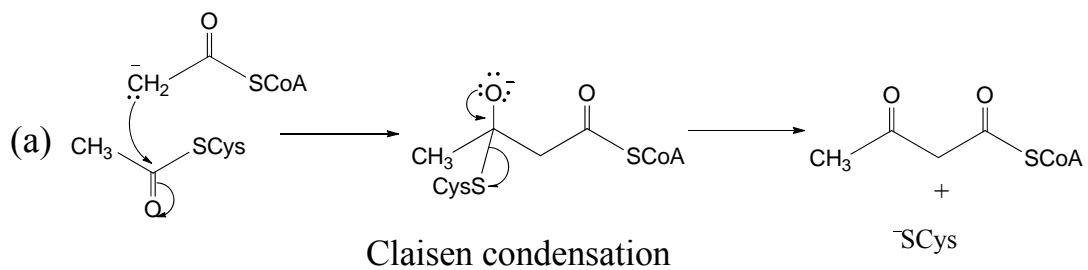

Claisen condensation is a nucleophilic substitution to an acyl group (ester or thioester), while Aldol condensation is a nucleophilic addition to a carbonyl group (aldehyde or ketone).

8.24

The Claisen condensation occurs at acyl carbon so that a leaving group can be displaced from the tetra-coordinate intermediate. The Aldol condensation does not have this possibility because the reaction occurs at aldehyde or ketone carbonyl groups (exception- Fig. 7.28).

8.25

1) enolate formation

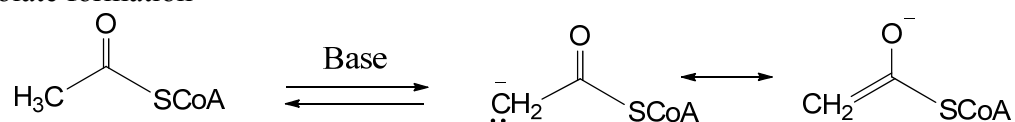

2) Claisen condensation

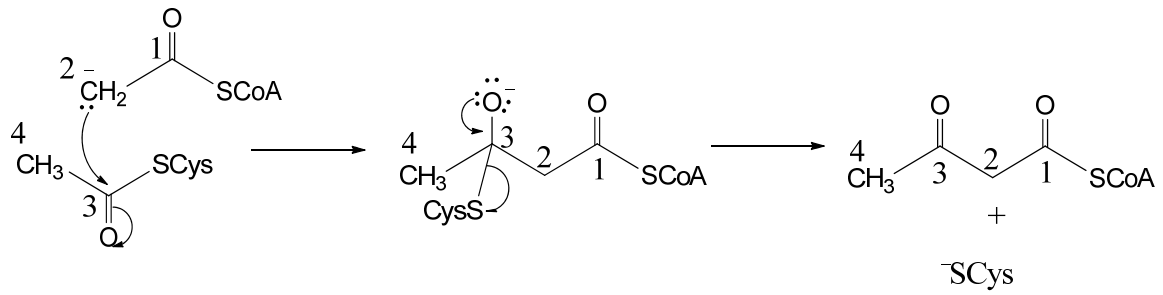

3) Aldol condensation

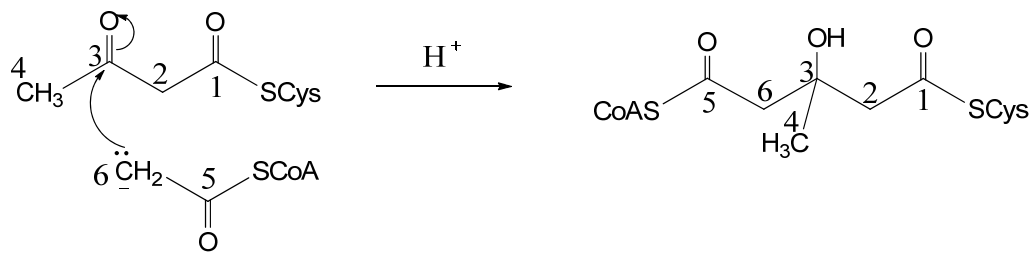

4) Hydrolysis of and reduction

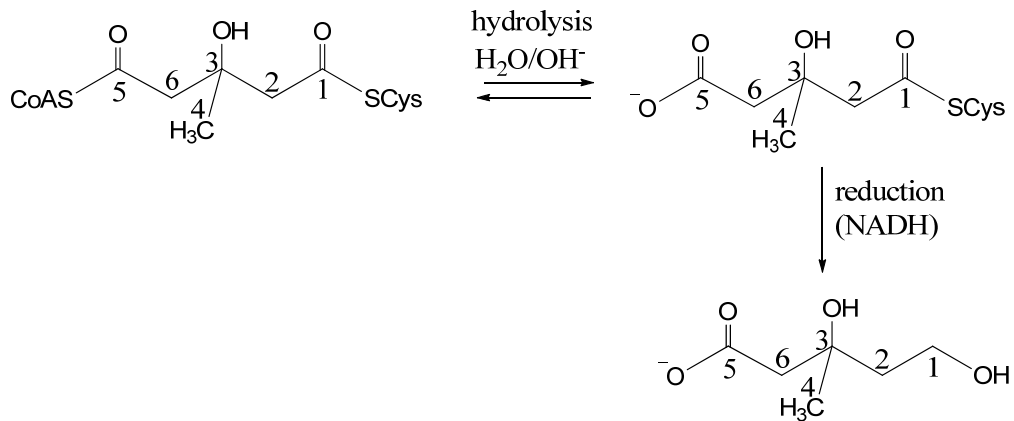

5) Phosphorylation followed by decarboxylation

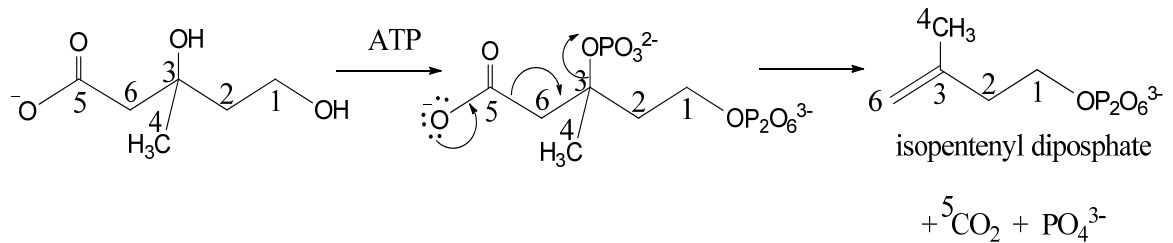

8.26

1) Acidic conditions

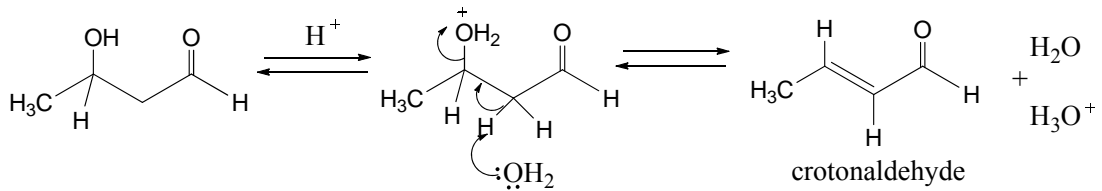

2) Basic conditions

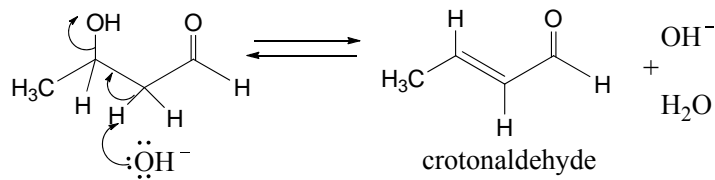

8.27

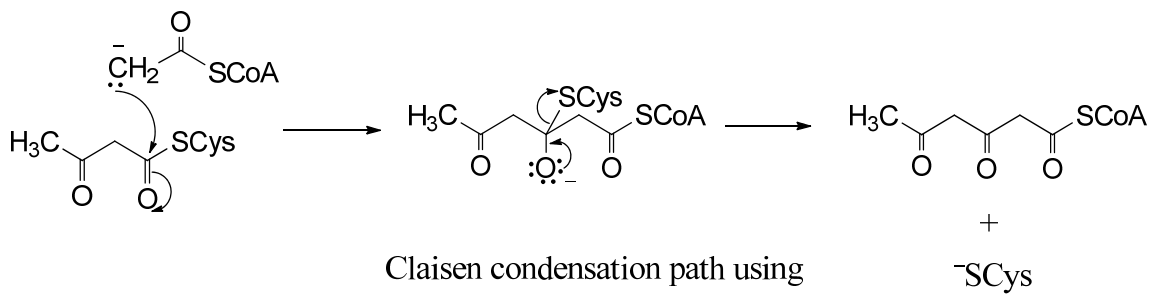

Claisen condensation path using intermediates in Fig. 8.15.

8.28

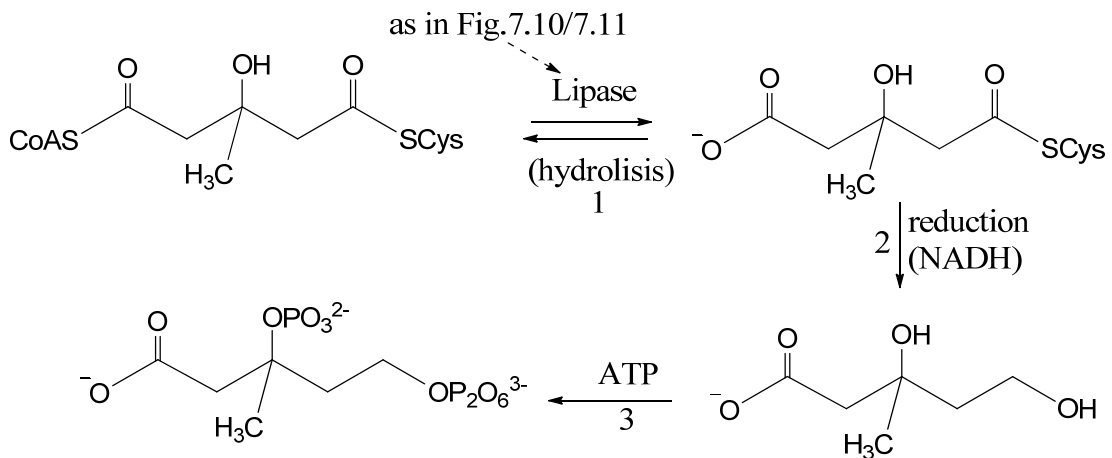

8.29

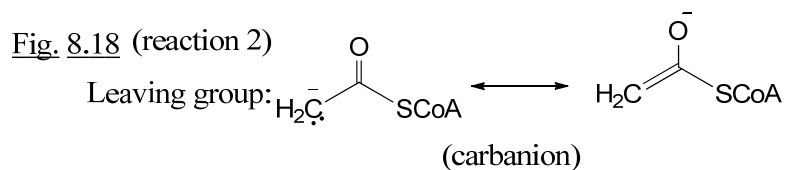
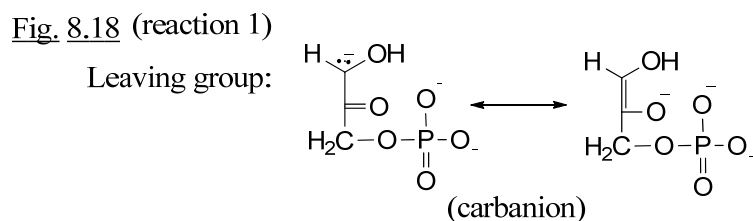
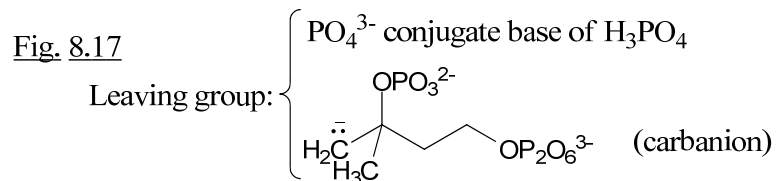

8.30

No answer required

8.31

Yes. Both reactions involve C-C bond breaking and formation of a carbanion intermediate which, in Fig. 8.17, is stabilized by the release of  $\text{PO}_4^{3-}$ , an excellent leaving group, while the carbanions formed in Fig. 8.18 are resonance-stabilized by the  $\alpha$ -carbonyl group.

8.32

- *Steps 1 and 2*: Aldol condensation (parallel to steps in Fig. 8.14)
- *Step 3*: Addition anti-Markovnikov to an alkene (parallel to step 4 in Fig. 5.18)
- *Step 4*: Oxidation of a secondary alcohol to ketone (parallel to Fig. 7.25)
- *Step 5*: Decarboxylation reaction (parallel to Fig. 8.17)
- *Step 7*: Hydrolysis of a thioester to carboxylate (step 1 in Fig. 8.16)
- *Step 8*: Oxidation of saturated hydrocarbons to an alkene (Fig. 7.22)
- *Step 9*: Addition of  $\text{H}_2\text{O}$  to a double bond conjugated with a carbonyl (parallel to Fig. 7.23)
- *Step 10*: Oxidation of a secondary alcohol to ketone (parallel to Fig. 7.25)

8.33

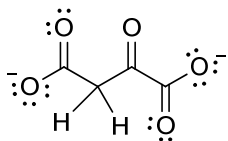

oxaloacetate  
- no violation of  
the octet rule

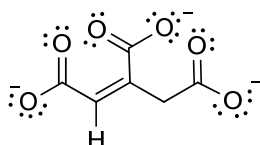

cis-aconitate  
- no violation of  
the octet rule

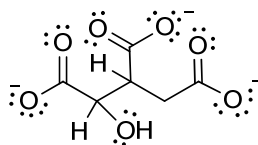

isocitrate  
- no violation of  
the octet rule

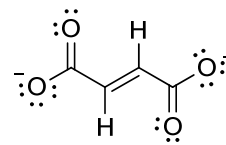

fumarate  
- no violation of  
the octet rule

8.34

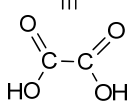
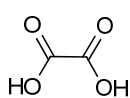

oxalic acid

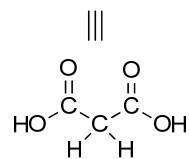
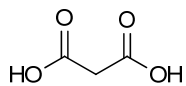

malonic acid

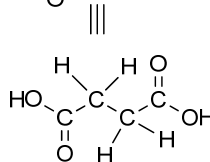
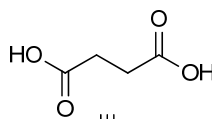

succinic acid

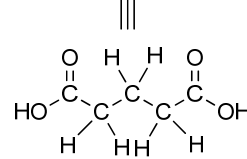
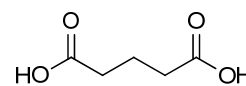

glutaric acid

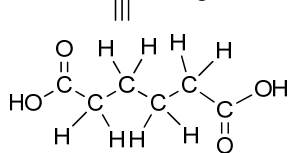
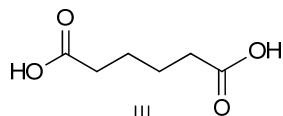

adipic acid

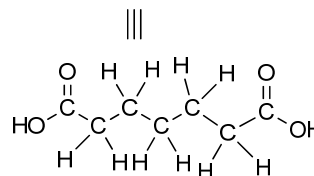
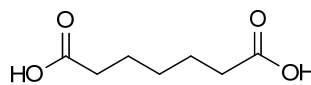

pimelic acid

8.35

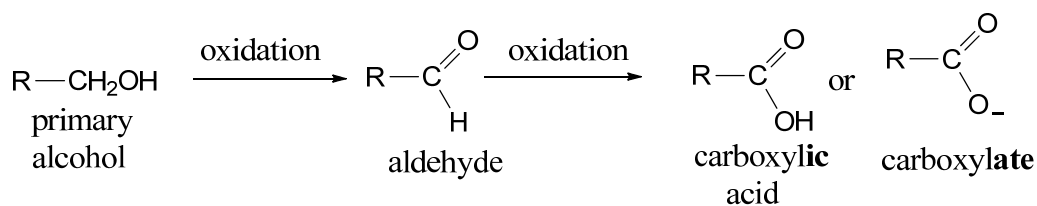

“ic” and “ate” refer to carboxylic acids and carboxylates (conjugate bases of carboxylic acids), respectively.



Examples:

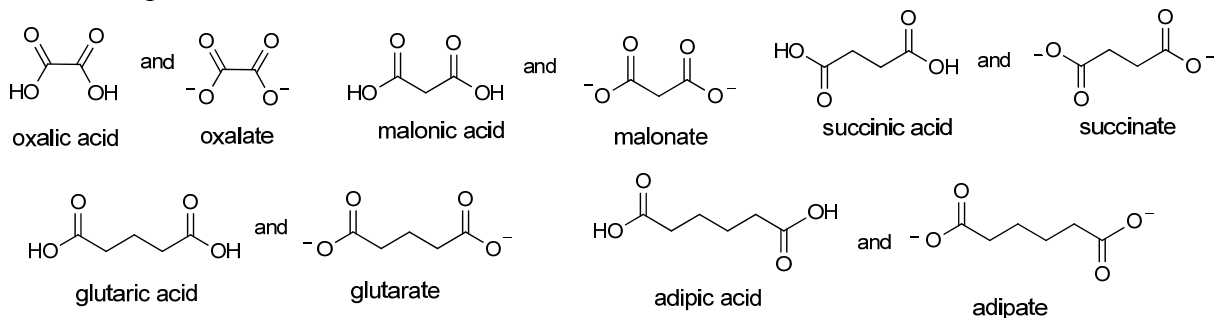

8.36

The conclusion to be drawn about Thumberg's experiments is that all the carboxylic acids he tested are converted into the same intermediate (see citric acid cycle).

8.37

- *Step 1:* No stereochemistry involved but in enzymatic process the two  $-\text{CH}_2\text{CO}_2^-$  of citrate are different (enantiotopic)
- *Step 2:* Cis (Z)/trans (E)

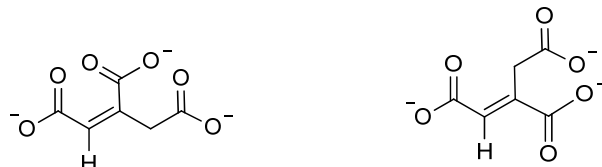

- *Step 3:* (R)/(S) configurations for the product

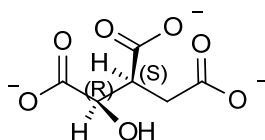

- *Step 4:* Loss of (R) configuration; (S) configuration is conserved.
- *Step 5:* Loss of stereochemistry
- *Step 6:* no stereochemistry involved
- *Step 7:* no stereochemistry involved
- *Step 8:* Cis/trans

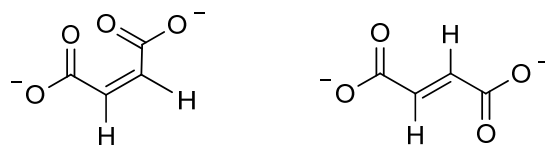

- *Step 9:* (R)/(S) configuration

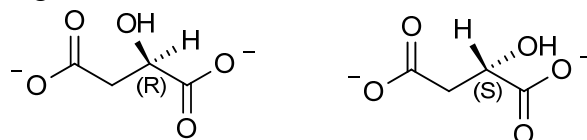

- *Step 10:* Loss of stereochemistry

8.38

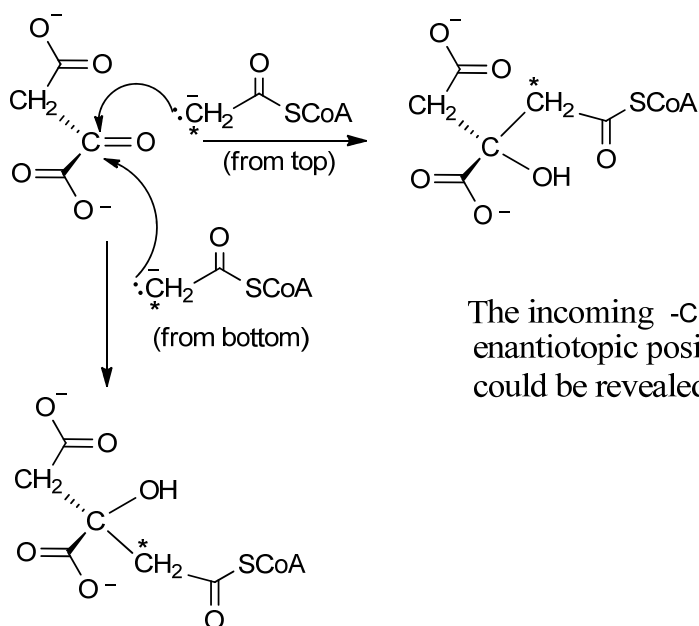

The incoming  $-\text{CH}_2\text{C}(=\text{O})\text{SCoA}$  group would occupy enantiotopic positions in citrate product, which could be revealed by labelling.

8.39

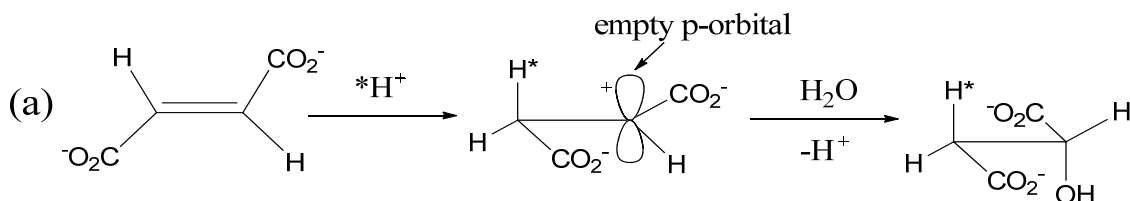

(b) Newman projection

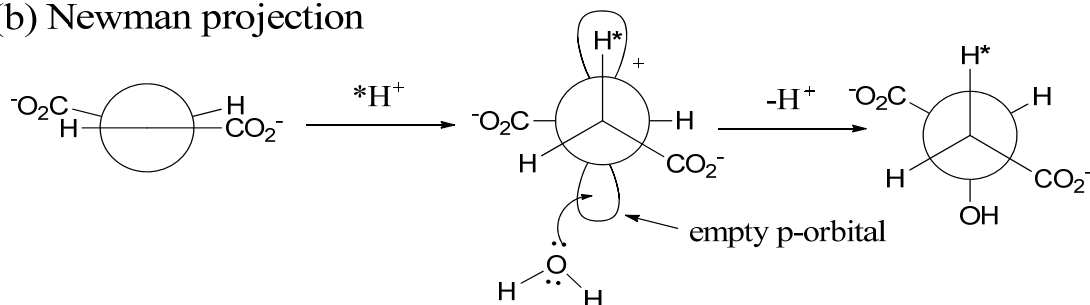

8.40

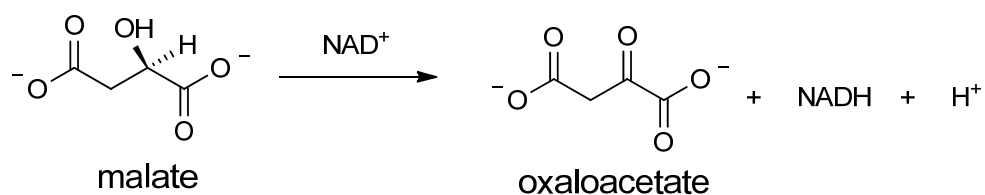

Malate is a chiral molecule and its biological oxidation by  $\text{NAD}^+$  is stereospecific although the final product (oxaloacetate) is achiral.

8.41

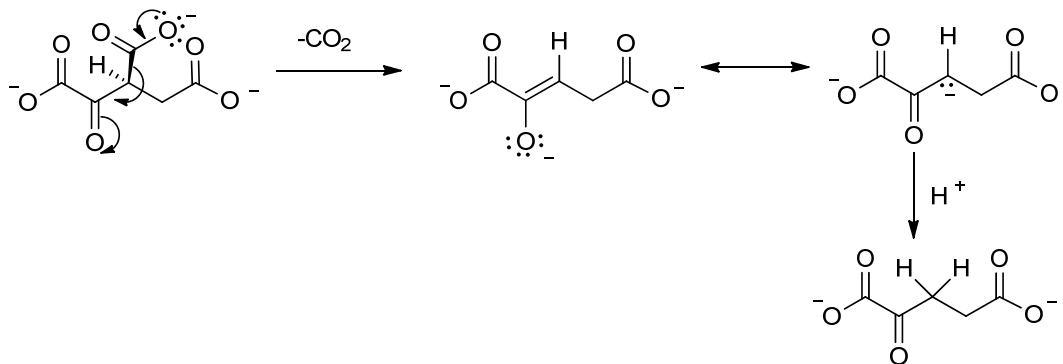

8.42

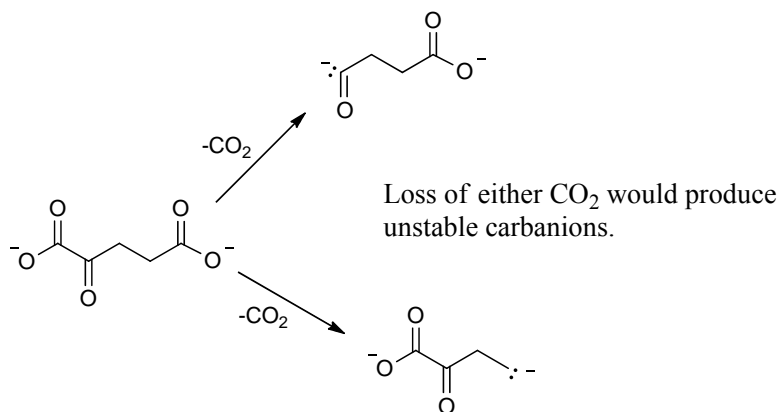

But as in Problem 8.41:

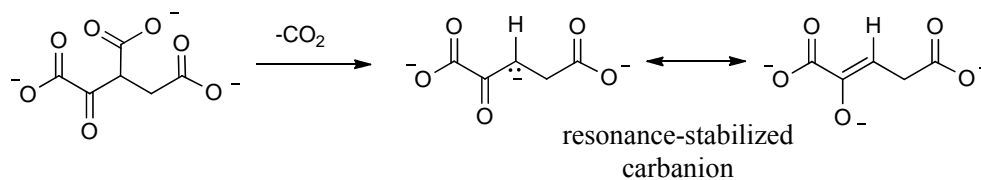

8.43

- Step 8 is comparable to the oxidation of fatty acyl CoA in Fig. 7.22

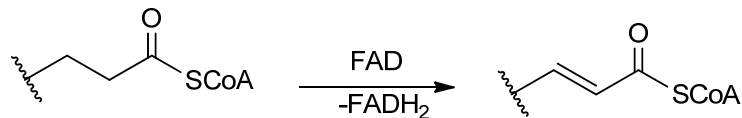

- Step 9 is comparable to addition of water to a double bond as shown in Fig. 7.23

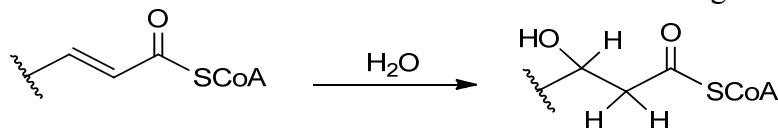

- Step 10 is comparable to the enzyme-catalyzed oxidation of  $\beta$ -hydroxy-fatty acyl CoA to the derived  $\beta$ -keto thioester (Fig. 7.25)

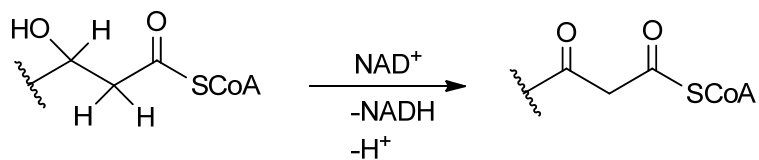

8.44

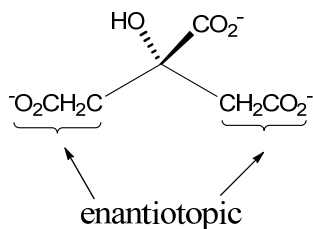

The enzymatic process is stereospecific and the enzyme will choose only one of the two  $\text{CH}_2\text{CO}_2^-$  groups. Therefore, loss of an hydrogen atom in the subsequent step occurs specifically from citrate on one of the  $\text{CH}_2\text{CO}_2^-$  groups.

8.45

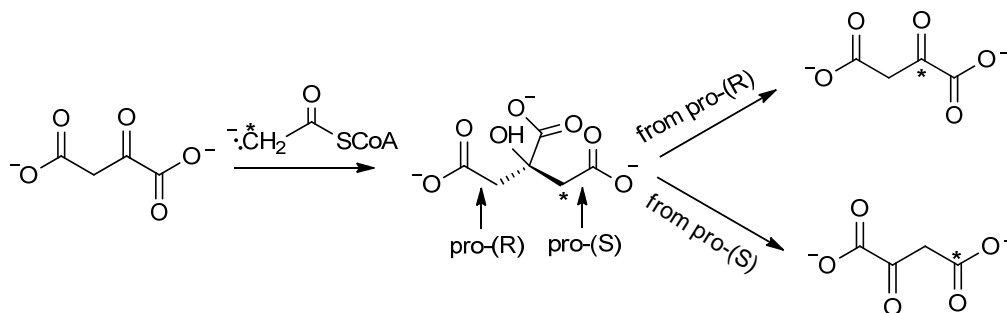

In the pro-(R) path, the two carbon atoms of acetyl CoA are conserved while in the pro-(S), the acyl carbon atom is lost. The pro-(R)  $\text{CH}_2\text{CO}_2^-$  is the one involved in citric acid cycle.

8.46

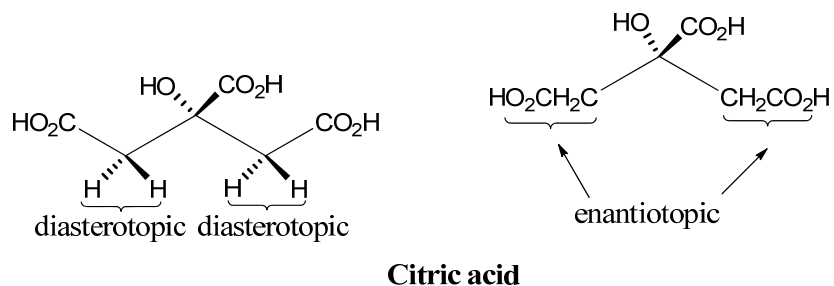

8.47

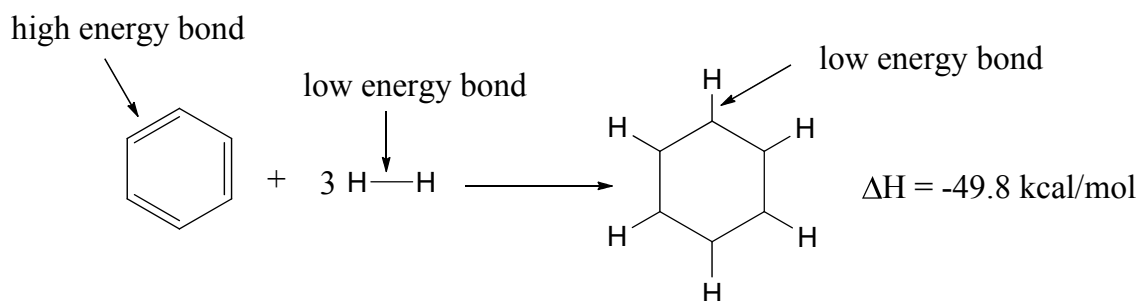
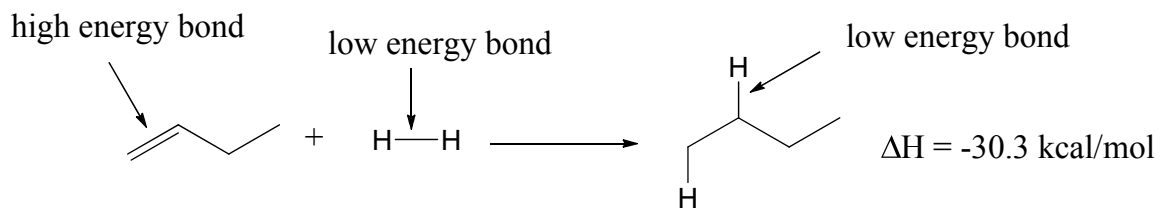

8.48

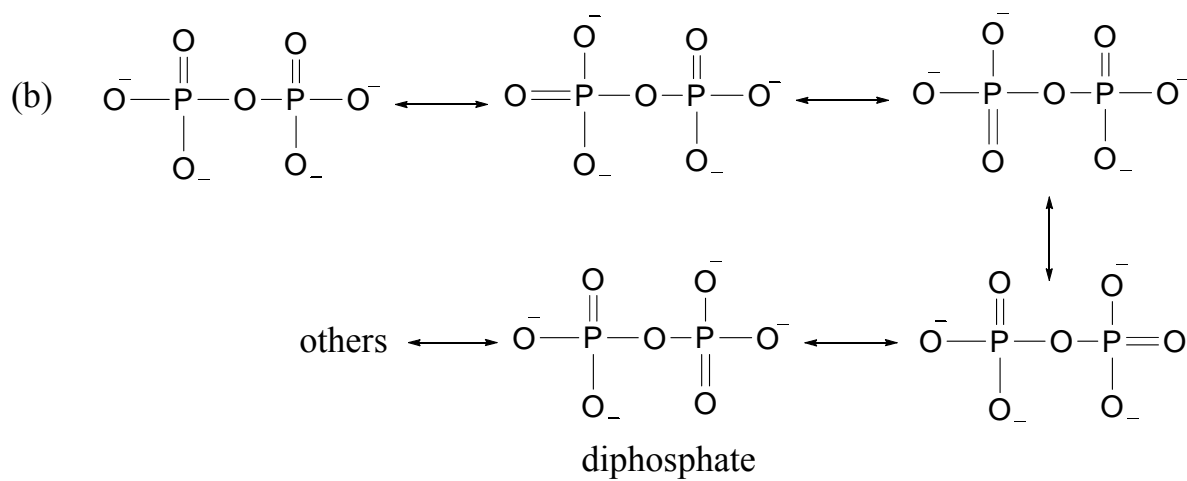
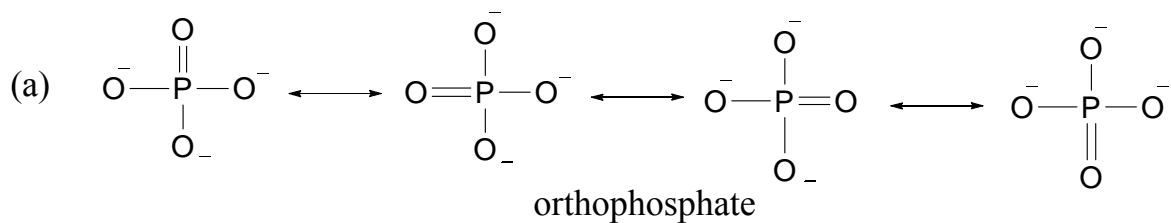

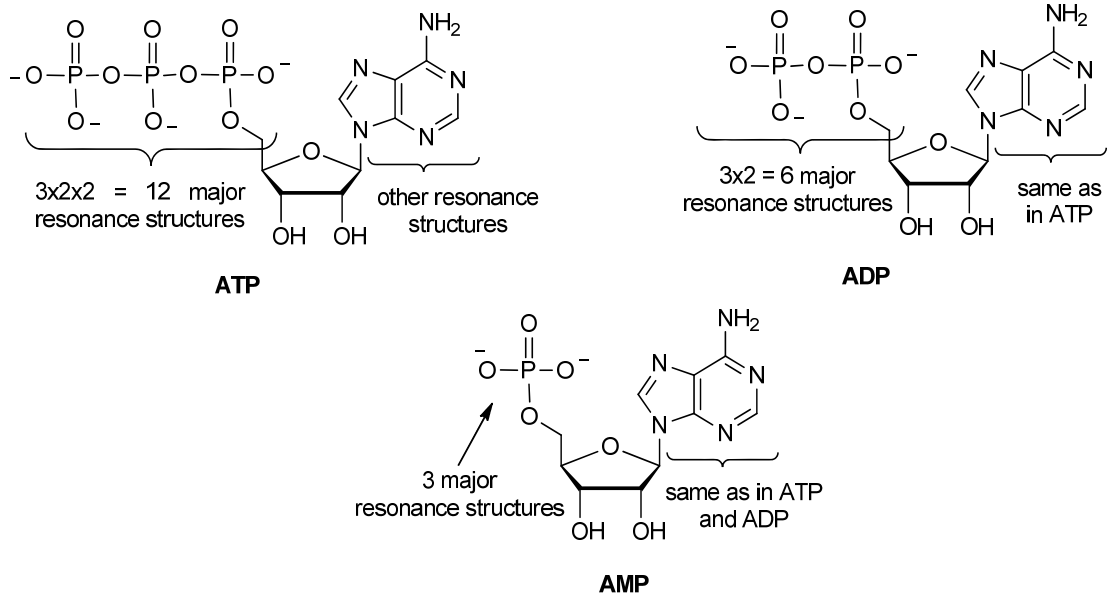

8.49

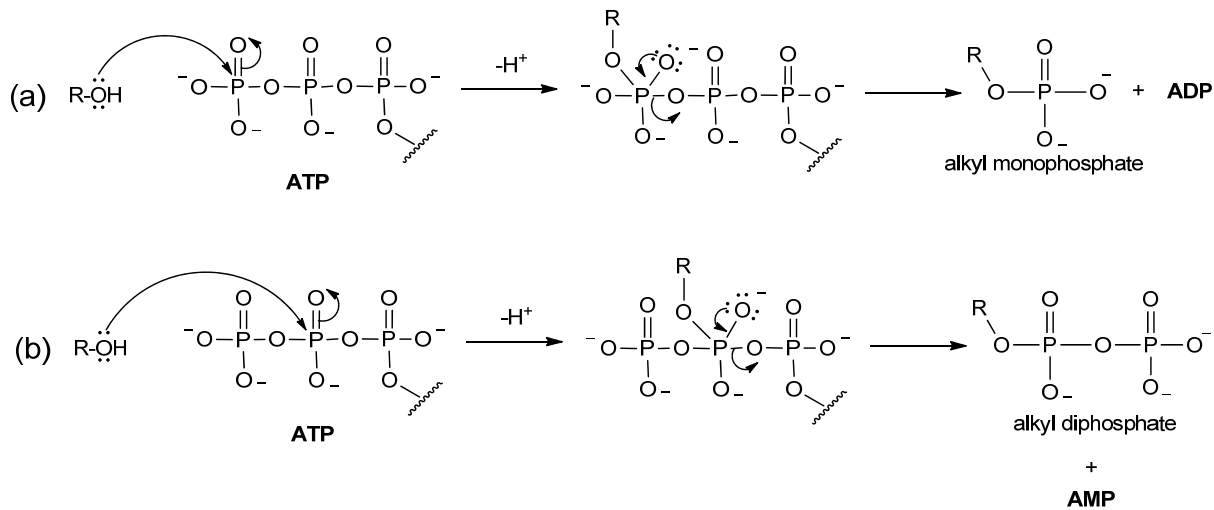

8.50

$\text{Mg}^{++}$  is used to balance the negative charges of the phosphate groups in ATP therefore increasing the stability.

Yes. In a hydrolysis step of ATP, the  $\text{PO}_4^{3-}$  ions are associated with magnesium ions ( $\text{Mg}^{++}$ ).

8.51

Fig. 8.17

ATP puts  $\text{PO}_4^{3-}$ , an excellent leaving group, in a precise structural position in order to accomplish the loss of  $\text{CO}_2$

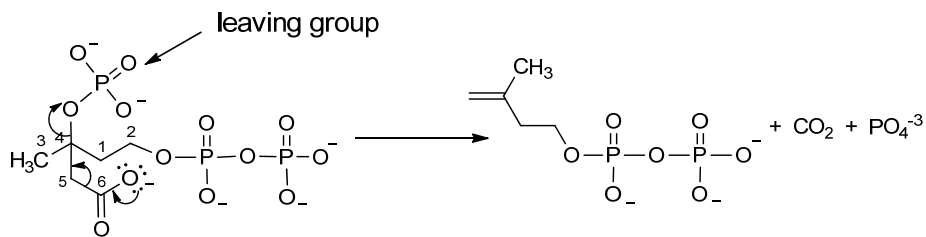

**Fig. 7.16, 1**

ATP makes the reaction possible by subsequent loss of  $P_2O_7^{4-}$ , an excellent leaving group.

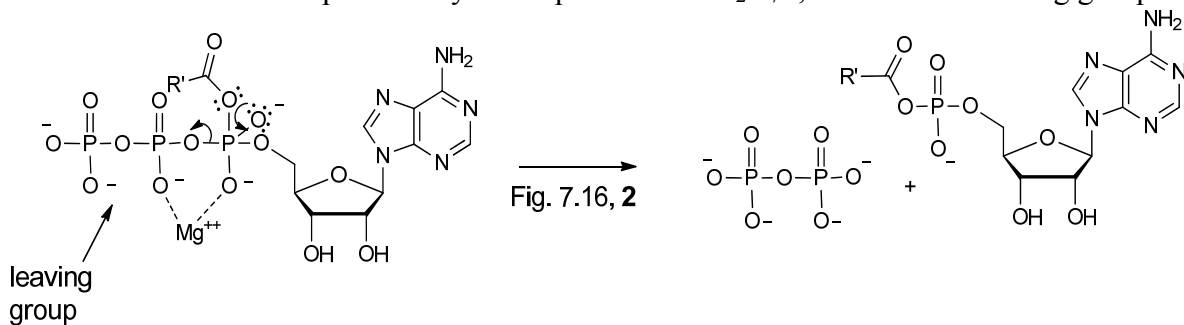

**Fig. 7.17, 1**

The reaction occurs because the phosphate group of acyl adenosyl phosphate (from ATP) is an excellent leaving group, which can be easily released in the subsequent step (Fig. 7.17, 2)

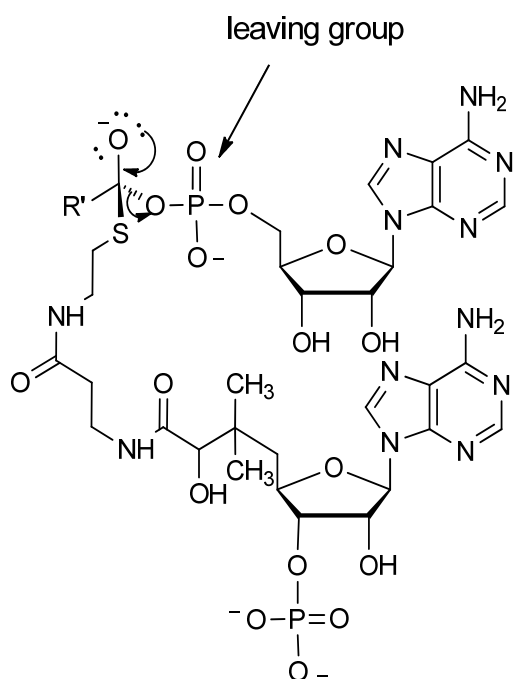

tetra-coordinate intermediate, from Fig. 7.17, 1

Figs. 5.12 and 5.13

ATP places the pyrophosphate group ( $\text{P}_2\text{O}_7^{4-}$ ), an excellent leaving group, on a carbon atom that becomes a resonance-stabilized carbocation when  $\text{P}_2\text{O}_7^{4-}$  is released.

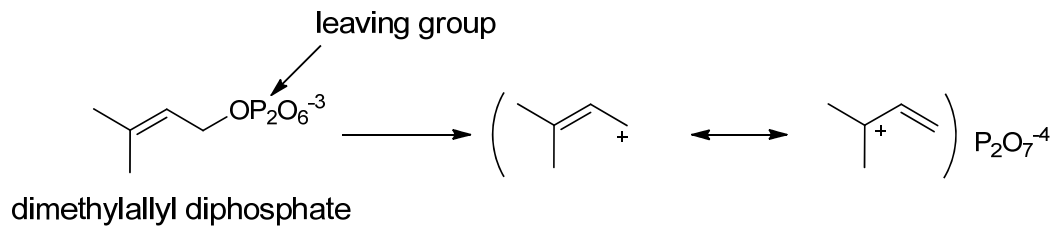



## Chapter 9

### 9.1

Starch and cellulose are not *addition polymers*.

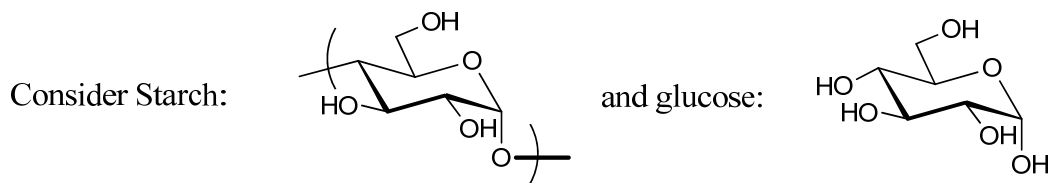

their formulas differ by a molecule of water

### 9.2

Consider the following equilibrium in the gas phase:

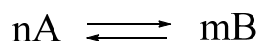

$$P_i = \frac{n_i P_{\text{tot}}}{n_{\text{tot}}} = \frac{n_i P_{\text{tot}}}{n_i + n_j} \quad P_i = X_i P_{\text{tot}}$$

$X_i$  is the molar fraction and  $P_{\text{tot}}$  is the total pressure

- If  $m > n$  i.e. increase of number of molecules from left to right, large increases of pressure ( $P_{\text{tot}}$ ) would shift the equilibrium to the left in order to keep " $K_{\text{eq}}$ " constant, according to Le Chatelier's principle.
- If  $m < n$ , large increases of pressure would shift the equilibrium to the right towards the products.

### 9.3

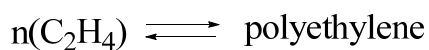

The number of molecules decreases from left to right (from " $n$ " to 1). An increase of pressure shifts to the right, therefore increasing the yield of polyethylene. Lowering the pressure would have hurt the ICI intended purpose.

### 9.4

ICI chemists were reasoning on the basis that the waxy solid has the same composition as ethylene, two hydrogen atom for each carbon atom,  $\text{CH}_2$ . Therefore, they concluded that it was a polymer of ethylene.

9.5

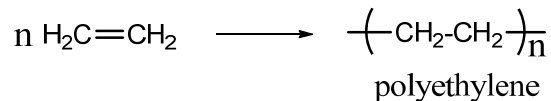

Polyethylene results from addition of “n” molecules of ethylene and is therefore called an *addition polymer*.

9.6

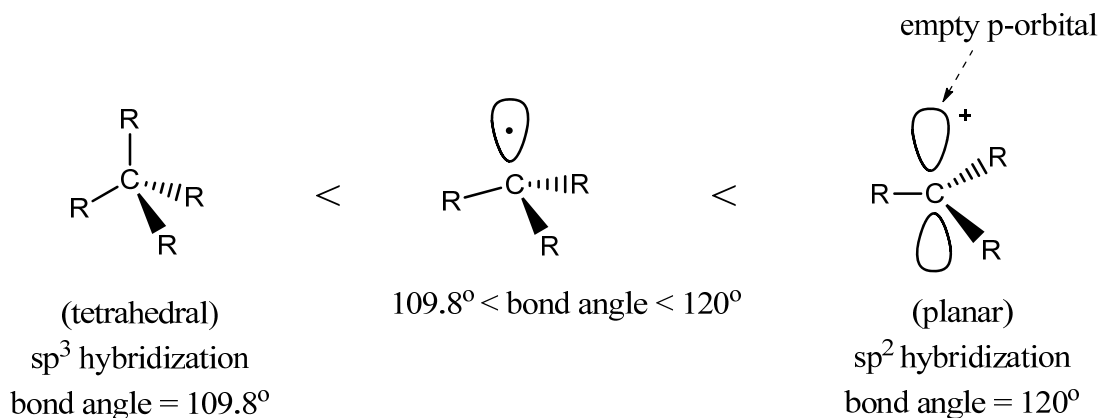

In a free radical, the necessary placement of a single electron in what would be an empty p-orbital in a carbocation causes some mixing of the 2s-orbital into that p-orbital leading to an hybridization type between  $sp^2$  and  $sp^3$ . Therefore, the three atoms bonded to the central carbon atom in the free radical no longer exist in a plane associated with  $sp^2$  nor do the three atoms bonded to the central carbon atom take a tetrahedral geometry.

9.7

Bond breaking is an endothermic reaction ( $\Delta H > 0$ ). Therefore, weaker bonds such as O-O ( $\Delta H = +35$  kcal/mol, average) would break at lower temperatures, where this energy becomes accessible, than stronger bonds such as C-C ( $\Delta H = +83$  kcal/mol, average), which requires higher temperatures to reach this energy.

9.8

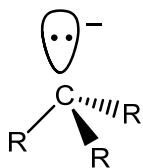

The lone pair of electrons and the bonding electrons repel each other leading therefore to a bond angle smaller than that of a regular tetrahedral ( $109.8^\circ$ ).

9.9

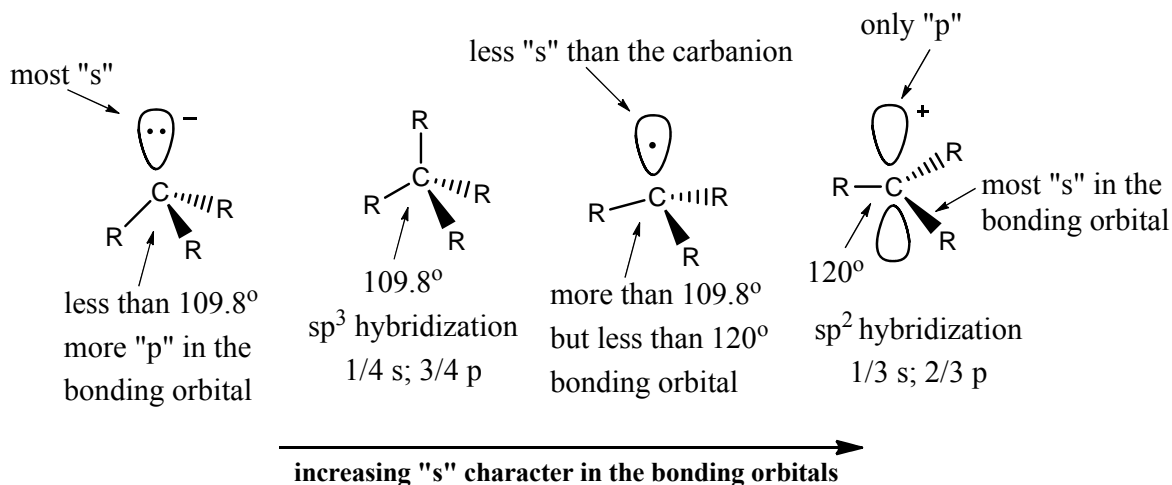

9.10

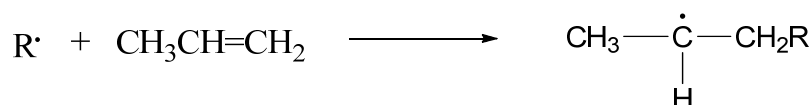

It would be expected that the radical  $\text{R}\cdot$  would add to propylene in the way of forming the more substituted radical, considering that the radical is electron deficient, although less so than a carbocation.

9.11

Other termination reactions are:

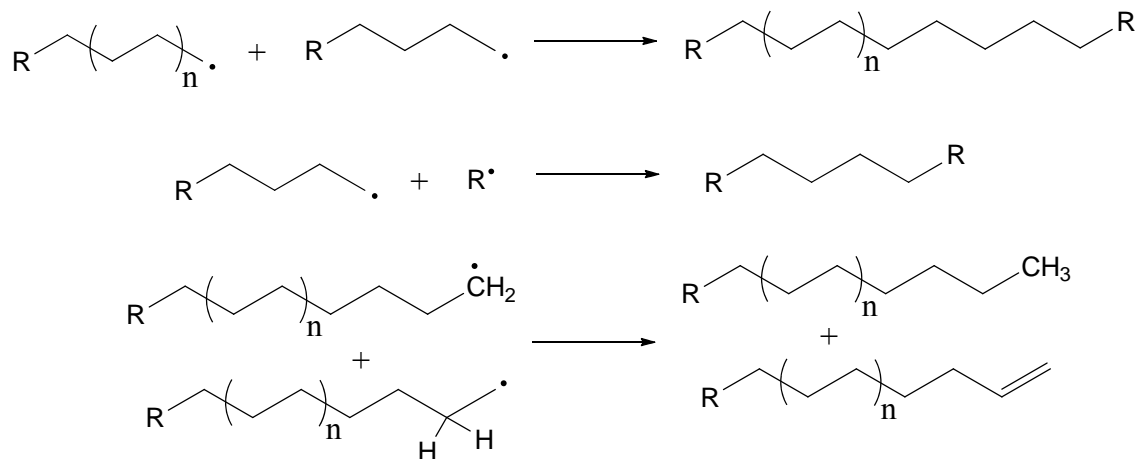

9.12

The mechanism for formation of branches in polyethylene reveal that stabilities of radicals are parallel to those of carbocations as testified by step 1 (Fig. 9.4) which shows the shift from a primary radical to a secondary one.

9.13

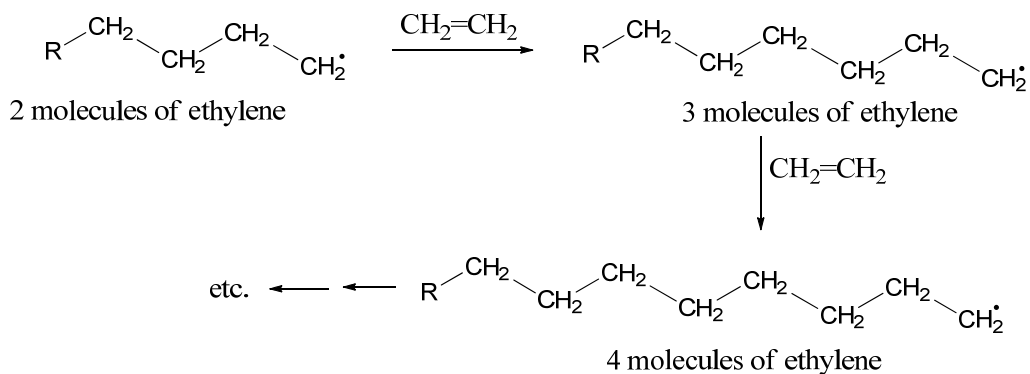

9.14

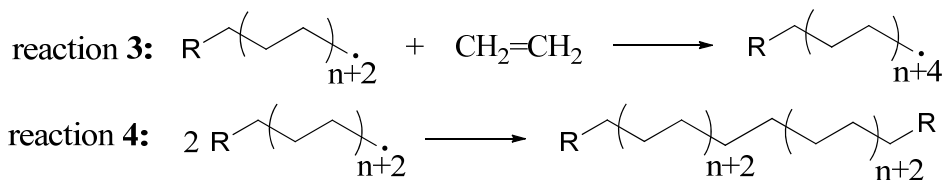

$$\text{rate (reaction 3)} = k_3[\text{CH}_2=\text{CH}_2][\text{R}-\left(\text{CH}_2\text{CH}_2\right)_{n+2}\cdot]$$

$$\text{rate (reaction 4)} = k_4[\text{R}-\left(\text{CH}_2\text{CH}_2\right)_{n+2}\cdot]^2$$

The rate of reaction 3 is proportional to  $[\text{R}-\left(\text{CH}_2\text{CH}_2\right)_{n+2}\cdot]$  while the rate of reaction 4 is proportional to  $[\text{R}-\left(\text{CH}_2\text{CH}_2\right)_{n+2}\cdot]^2$ . Therefore, as more chains are produced, reaction 4 is increasingly favored over reaction 3.

The rate of reaction 3 is also proportional to  $[\text{CH}_2=\text{CH}_2]$  while that of reaction 4 does not depend on  $[\text{CH}_2=\text{CH}_2]$ . Therefore, adding more ethylene to the reactor would favor reaction 3 over reaction 4.

9.15

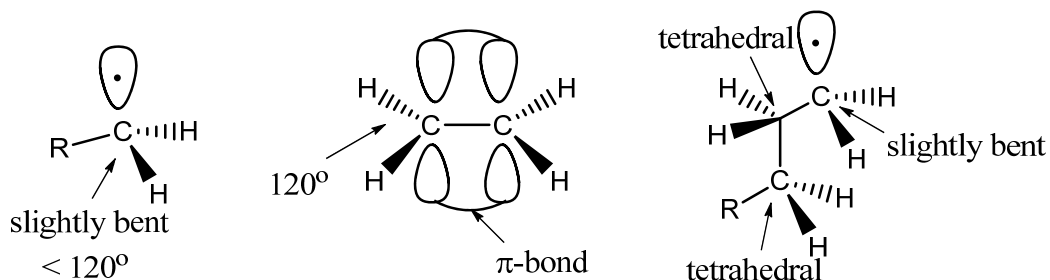

9.16

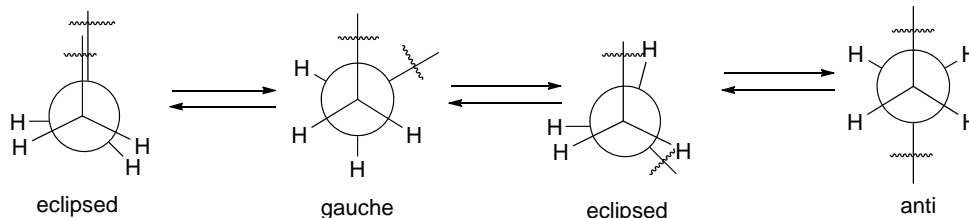

Torsional motions cause a large change in the shape of polyethylene chain. This is reasonable due to high flexibility of the polymer.

9.17

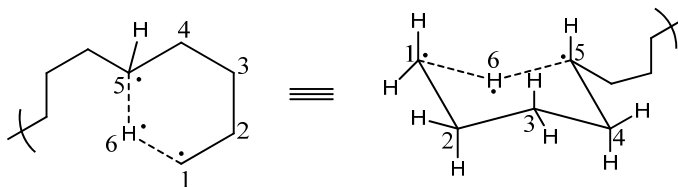

Conformational transition state (reaction 1, Fig. 9.4)

9.18

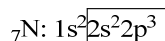
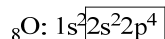
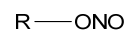

**Accounting of valence electrons**

- two oxygen atoms =  $2 \times 6 = 12$

- one nitrogen atom =  $1 \times 5 = 5$

- one electron from (R) = 1

total = 18

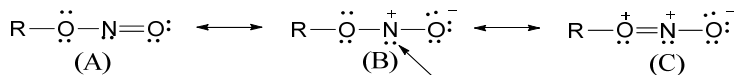

- obeys the octet rule  
- no formal charge

violates the octet rule

obeys the octet rule

Of the three resonance structures, only (A) has no formal charge and obeys the octet rule.

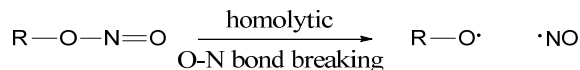

- violates the octet rule  
- no formal charge

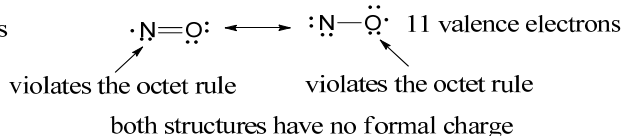

9.19

No answer required.

9.20

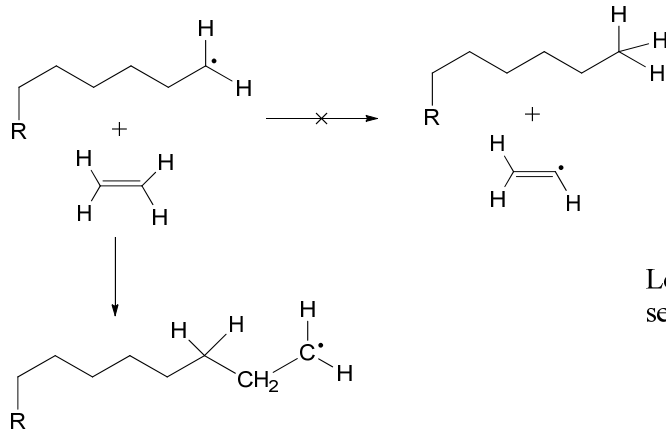

9.21

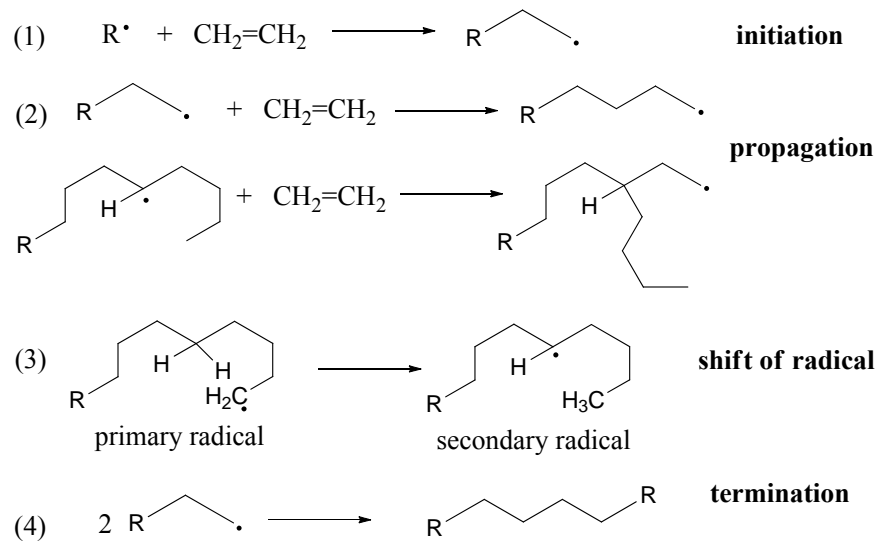

9.22

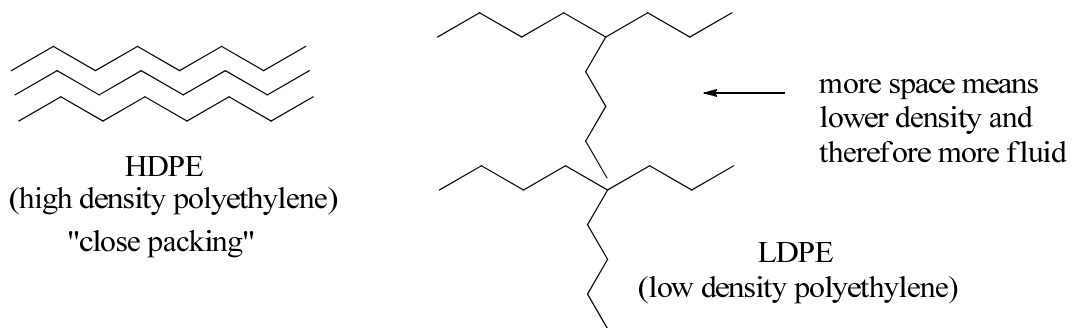

While linear polyethylene (HDPE) allows close packing, the branches in LDPE cause a chain shape that disrupt packing of the chains therefore lowering the density of the polymer.

9.23

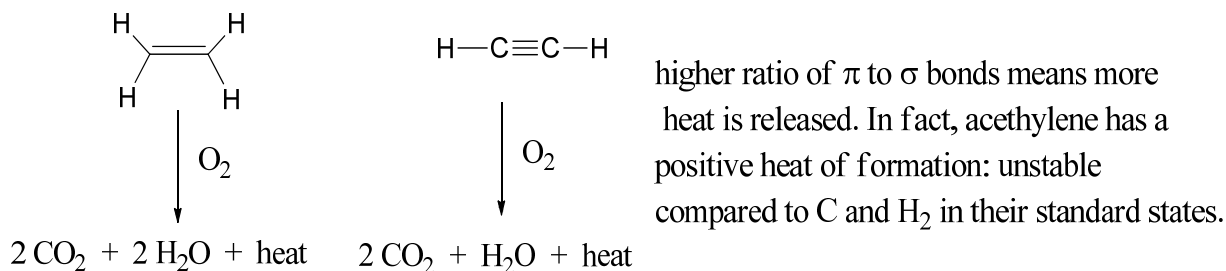

9.24

Steam cracking high temperature allows:

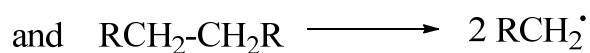
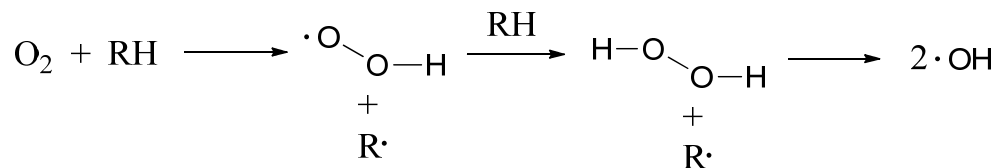

Lower temperature for ethylene may allow only reaction with oxygen

9.25

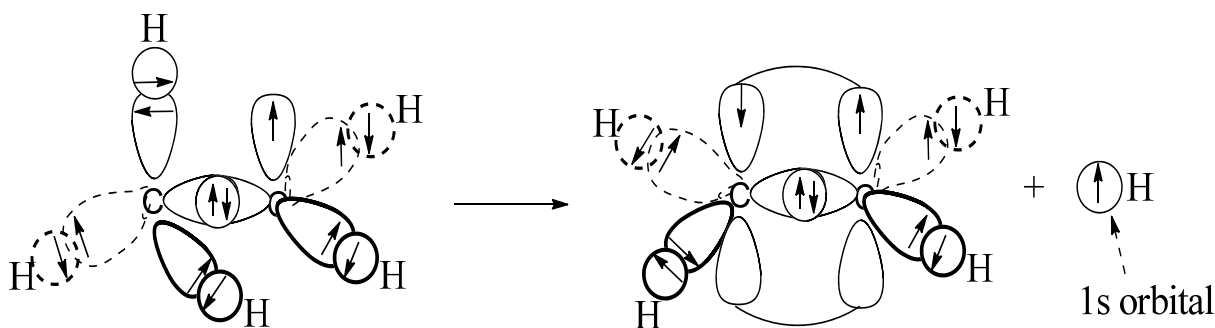

9.26

(a) ethylene

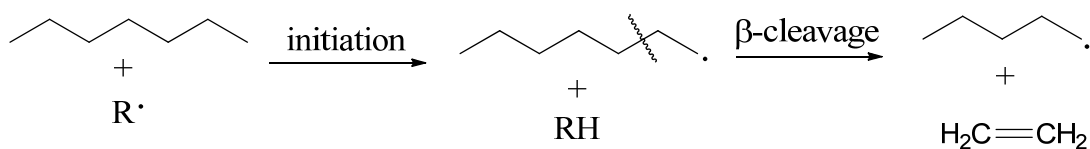

(b) propylene

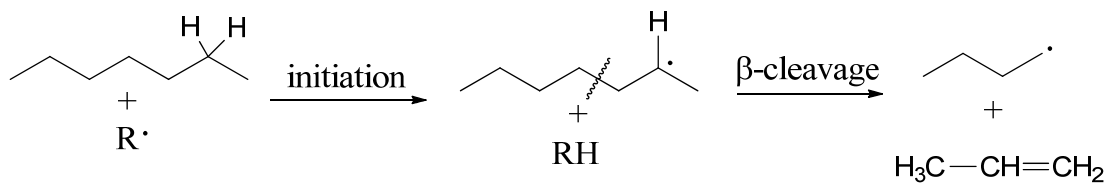

(c) 1-butene

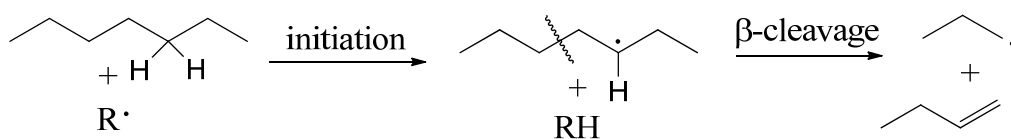

(d) 2-butenes

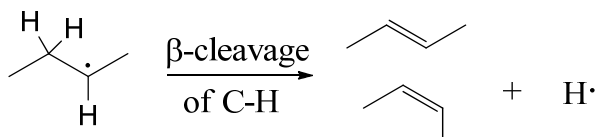

9.27

Some reasonable termination reactions are:

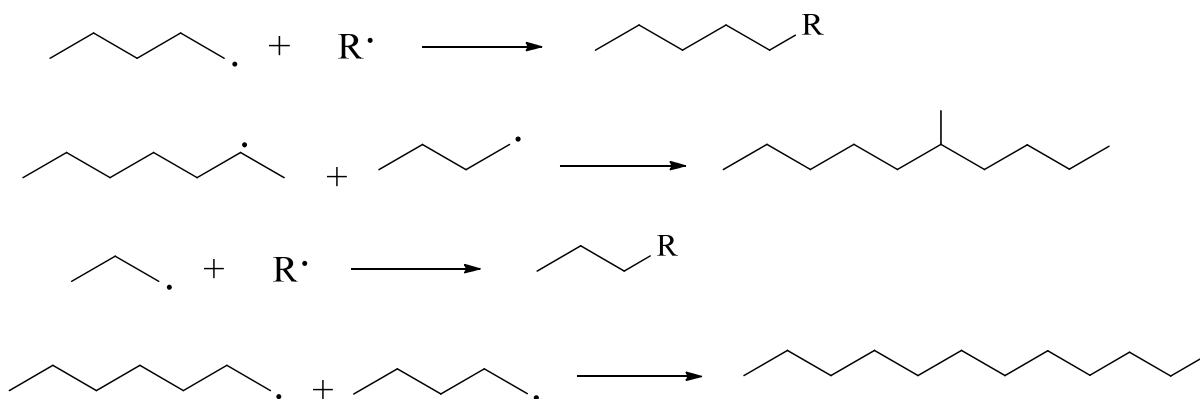



9.28

Steam cracking is endothermic: strong bonds are broken. Also there is  $+\Delta S$  and therefore temperature increase is favored.

Ethylene polymerization is exothermic: weak bonds are converted to strong bonds. Also there is  $-\Delta S$  and therefore temperature increase lowers the equilibrium constant.

9.29

$$\Delta G = \Delta H - T\Delta S$$

In steam cracking process, few molecules are converted to large number of small molecules (increase in disorder). This increase in disorder is translated to a favorable positive  $\Delta S$  (change in entropy) term. Furthermore, conversion of  $\sigma$  to  $\pi$ -bond in steam cracking is an endothermic reaction (positive  $\Delta H$ ), which is unfavorable. Therefore, higher temperatures would favour the steam cracking.

$$\left. \begin{array}{l} \Delta H > 0 \\ \Delta S > 0 \end{array} \right\} \Longrightarrow \Delta G < 0 \text{ at high temperatures}$$

9.30

Conversion of a strong  $\sigma$ -bond to a weak  $\pi$ -bond (high energy bond) is an endothermic reaction; i.e. energy must be added to the system to compensate the formation of a weaker bond from a stronger bond, which translates to a higher temperature.

9.31

In polymerization, a  $\pi$ -bond is converted to a  $\sigma$ -bond. The enthalpy change ( $\Delta H$ ) is therefore exothermic (negative  $\Delta H$ ). Furthermore, a large number of small molecules are combined to form a macromolecule leading to a negative change in entropy (negative  $\Delta S$ ).

Since  $\Delta G = \Delta H - T\Delta S = (-\Delta H) - T(-\Delta S) = -\Delta H + T\Delta S$ , as temperature increases,  $\Delta G$  grows smaller and even may reach zero.

9.32

No. Thermodynamic parameters have nothing to do with the transition state which is instead related to the activation energy ( $E_{\text{act}}$ ) as discussed in section 6.11.

9.33

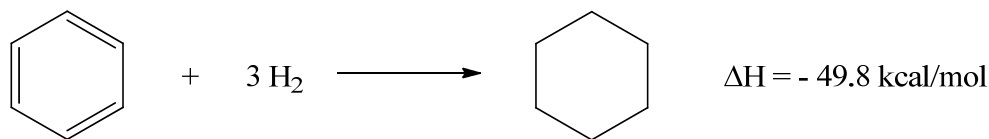

Hydrogenation of benzene is an exothermic reaction ( $\Delta H < 0$ ) and is accompanied by a negative change in entropy ( $\Delta S < 0$ , one molecule of benzene combines with three molecules of  $H_2$  to form one molecule of cyclohexane). Therefore, it resembles polymerization (see answer to problem 9.31).

9.34

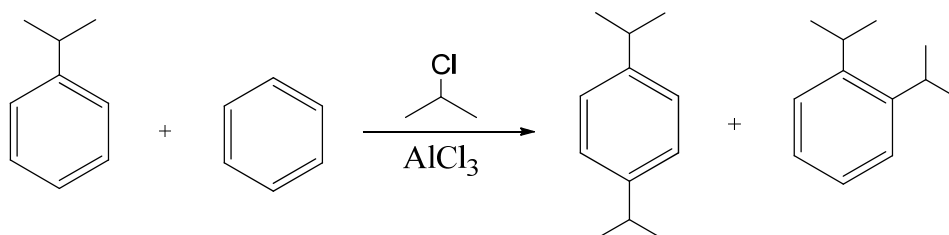

multi-alkylation stimulated by resonance effects (chapter 6)

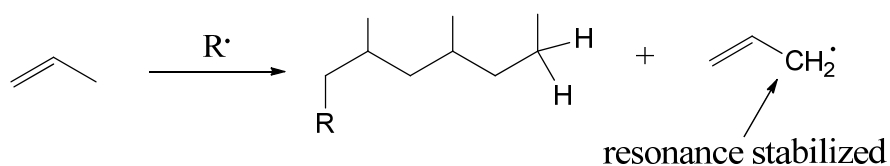

9.35

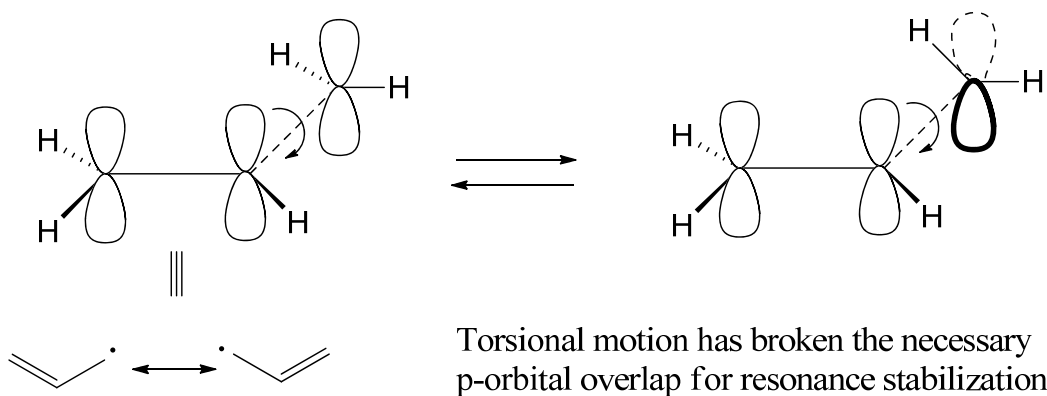

9.36

As seen in Fig. 9.9, the difference in  $E_{act}$  is similar to the resonance stabilization difference, therefore greatly slowing the higher  $E_{act}$  reaction.

9.37

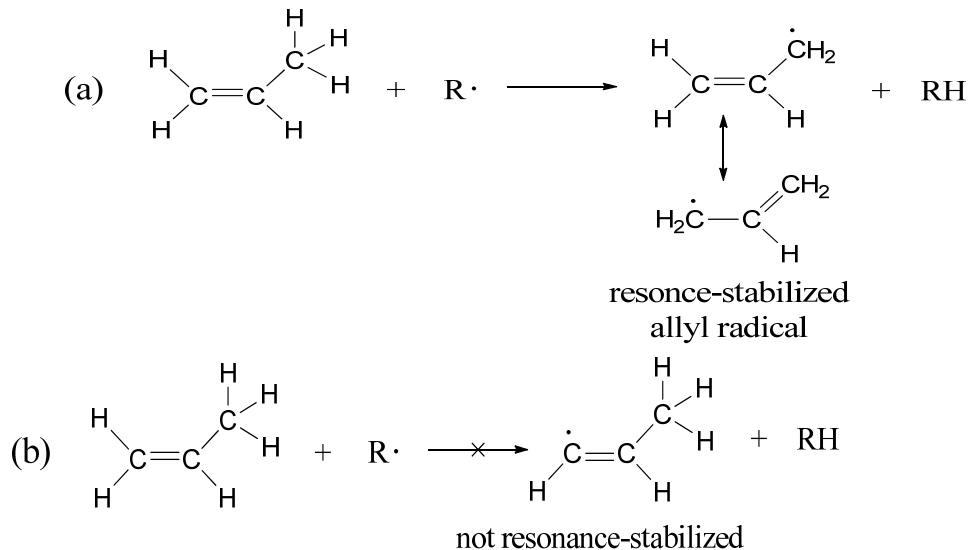

In addition, H bonded to  $sp^2$  carbon is a stronger bond than H bonded to  $sp^3$  carbon, even independent of the resonance stabilization.

9.38

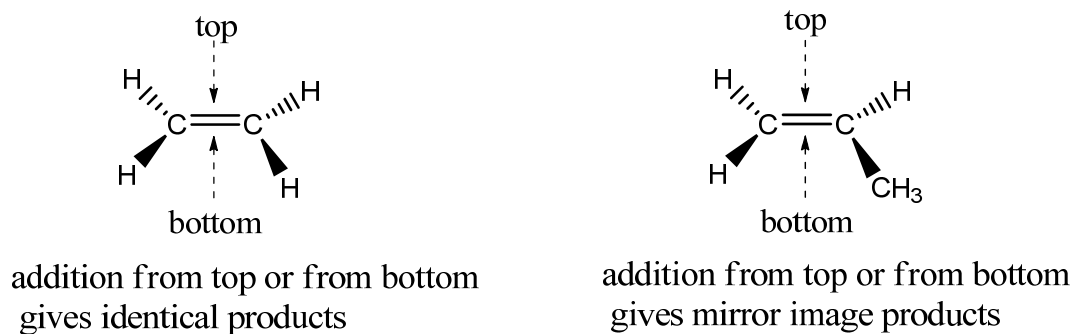

Therefore, the faces of ethylene are identical while those of propylene are enantiotopic (section 5.6).

9.39

Free radicals would cause branching.

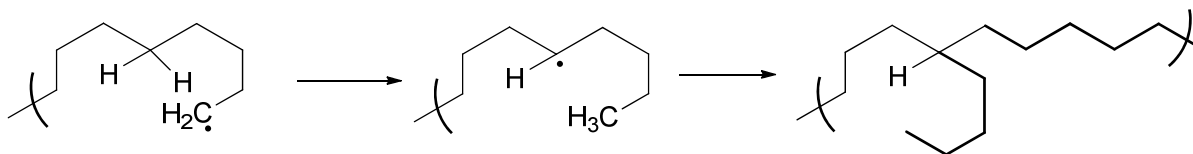

9.40

Yes. They are isomers. These polymers are *diastereomers* because they are stereoisomers which are not mirror-related images.

9.41

The two isotactic polymers in Fig. 9.10 are enantiomers because they are mirror images. This is strictly true only if the ends of the chains in both polymers are identical.

9.42

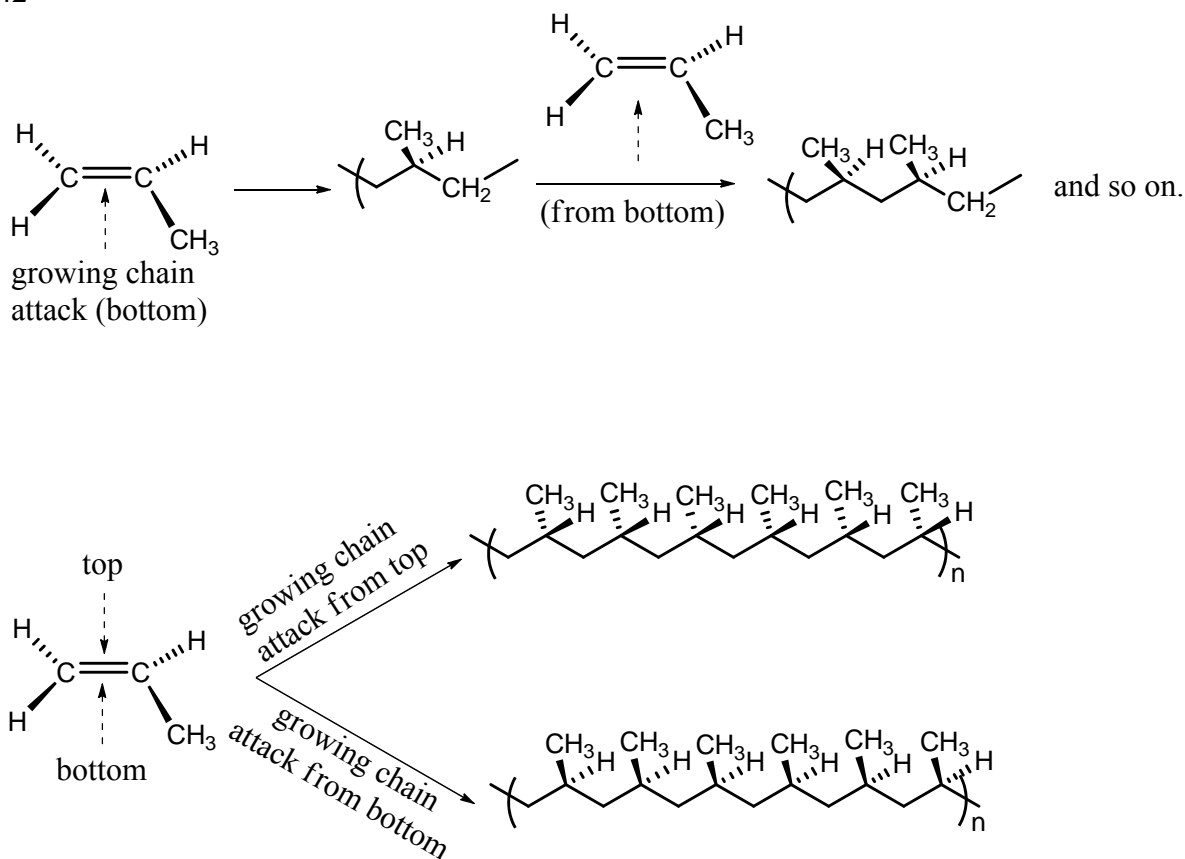

Both faces of the double bond are enantiotopic and the attack from the top and bottom would lead to isotactic polymers with opposite directions of the methyl groups.

9.43

The Ziegler catalyst is chiral and would specifically prefer one face of the propylene molecule over the other.

9.44

Yes. If the catalyst sites were related enantiomerically, one enantiomer would prefer one face of the propylene molecule while the other enantiomer would choose specifically the opposite face leading to a racemic mixture of polymers which could not be distinguished.

9.45

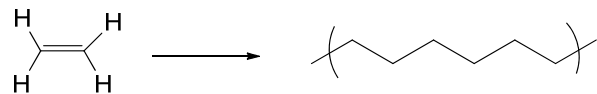

formula  $\text{CH}_2$  for both monomer and polymer

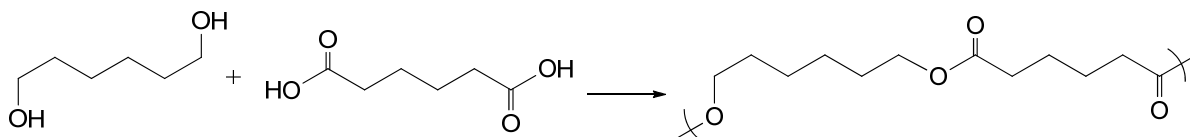

formulas for monomers and polymer differ by loss of  $\text{H}_2\text{O}$  for each link in the chain (each ester bond).

9.46

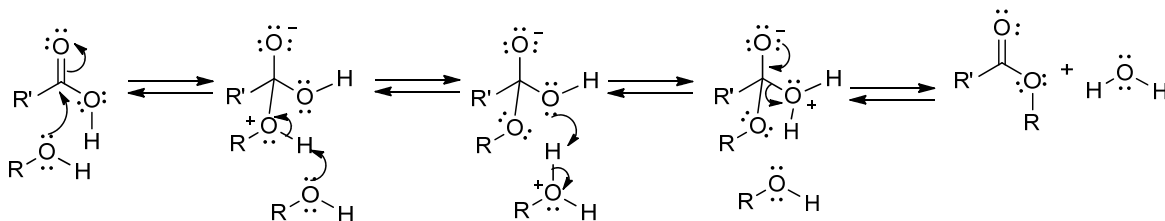

9.47

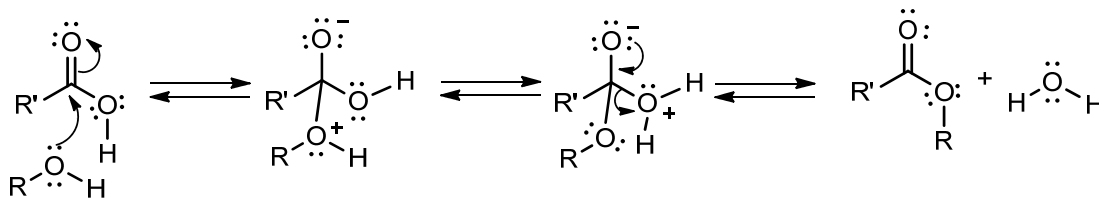

9.48

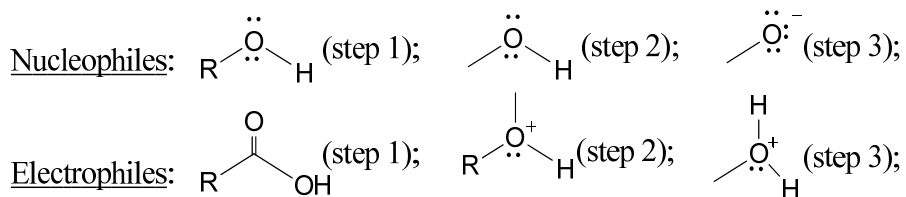

Step 2 is an acid/base reaction between  $\text{R}-\text{C}(\text{OH})_2^+$  and  $\text{H}-\ddot{\text{O}}-\text{H}$   
 (Bronsted-Lowry acid) (Bronsted-Lowry base)

9.49

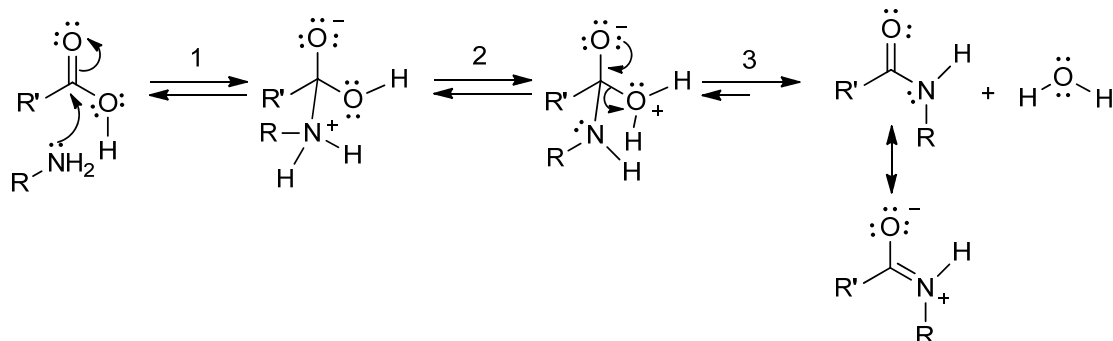

The equilibrium in step 3 greatly favors the amide therefore reducing hydrolysis. Ester bond – (CO)-OR has more single bond character than an amide bond –(CO)-NHR, as shown by resonance structures.

9.50

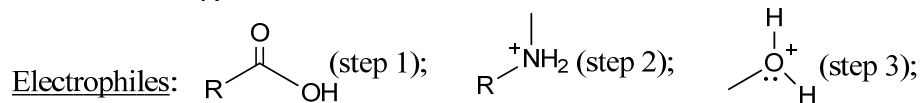
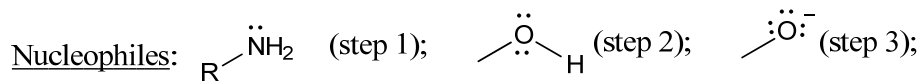
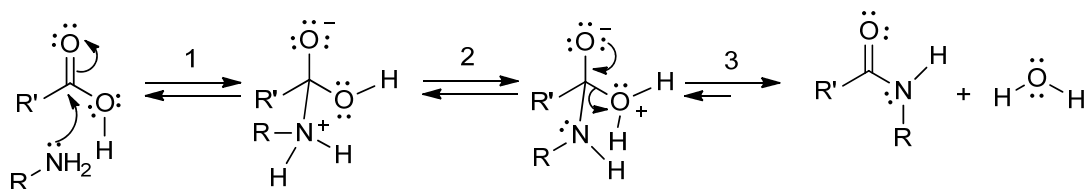

Step 2 is an acid/base reaction between  $\text{R}-\overset{+}{\text{N}}\text{H}_2$  (Bronsted-Lowry acid) and  $\text{H}-\ddot{\text{O}}-\text{H}$  (Bronsted-Lowry base); step 1 can also be seen as an acid/base reaction of the Lewis definition.

9.51

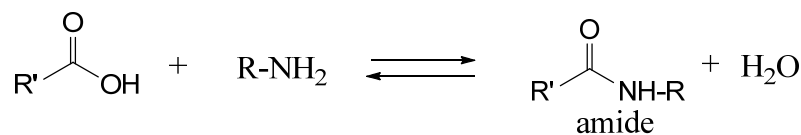
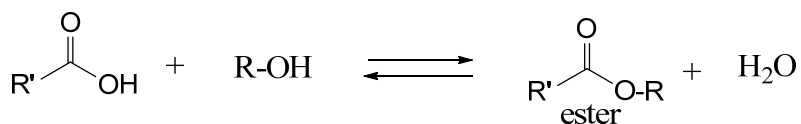

The equilibrium constants for hydrolysis are:

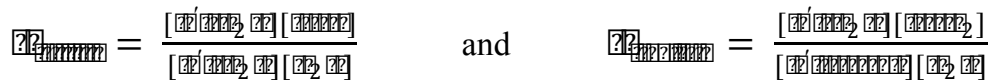

$K_{\text{ester}} \gg K_{\text{amide}}$ , therefore less hydrolysis occurs for amides than for esters.

9.52

The amide functional group has the following general structure:

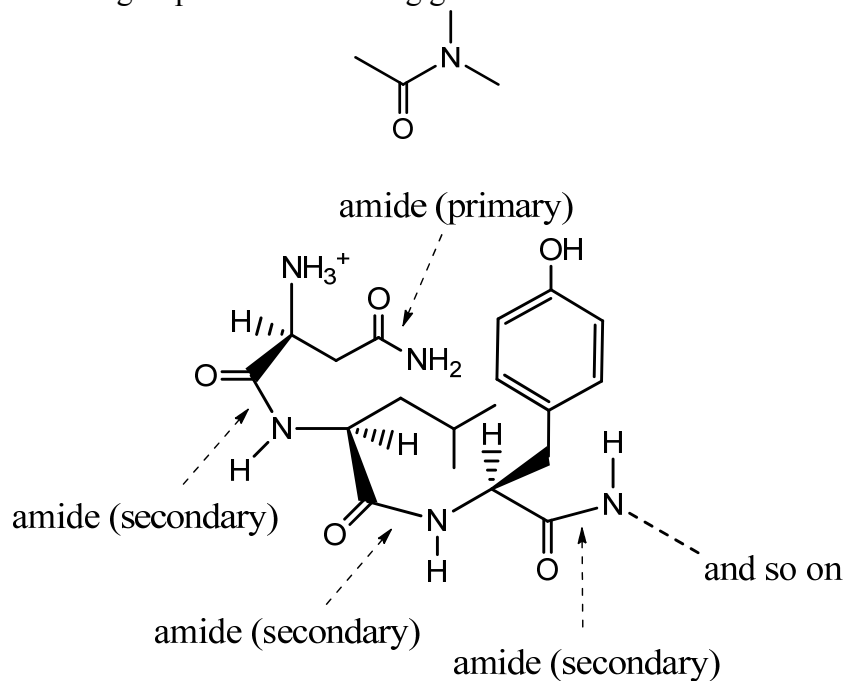

There is one amide group between every two residues (there are 20 residues) and one primary amide on the side-chain of asparagine (2 residues). Therefore, a total of 21 amide groups can be identified in the protein chain.

9.53

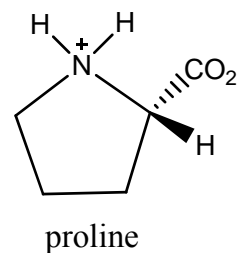
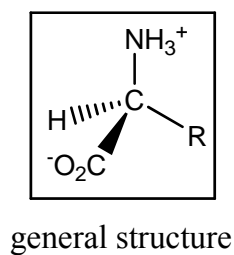

—R (side-chain group)

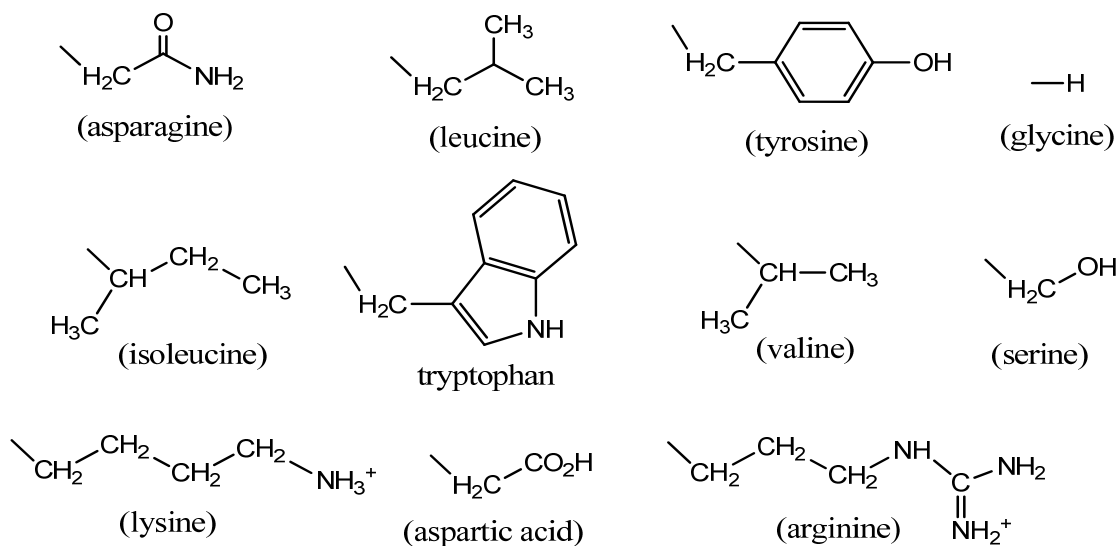

9.54

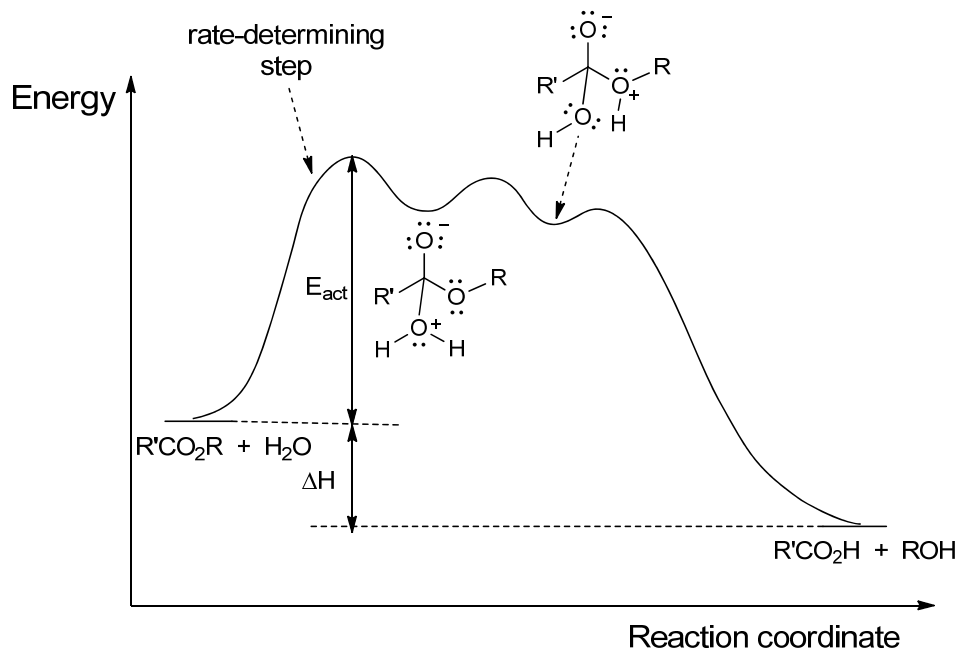
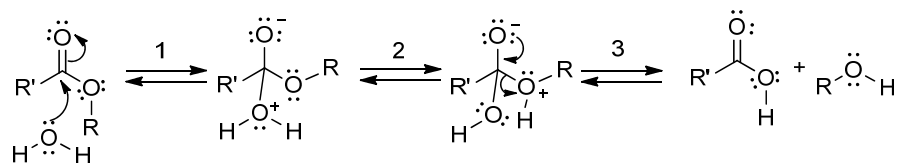

Step 1 is the rate-determining step



9.55

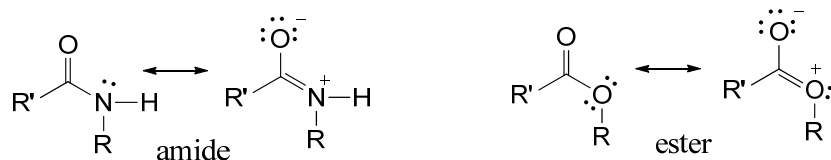

Oxygen atom is more electronegative than nitrogen atom. As a result, the double bond character between C and N is higher than that between C and O making more difficult the twisting of C-N bond.

$\text{:NH}_3$  is a stronger base than  $\text{H}_2\text{O}$ , which means that the electron pair is more available.

9.56

These three nylons differ on the length of the hydrocarbon chains in the two monomers. As the hydrocarbon chain increases, the polymer becomes less polar (more hydrophobic) and more flexible and with fewer H-bonds per unit. As a result, the melting point and the water absorption both decrease.

nylon 4,6 mp 300 °C EqH <sub>2</sub> O > 8%	>	nylon 6,6 mp 265 °C EqH <sub>2</sub> O = 8%	>	nylon 6,10 mp 225 °C EqH <sub>2</sub> O = 3%
---	---	---	---	--

9.57

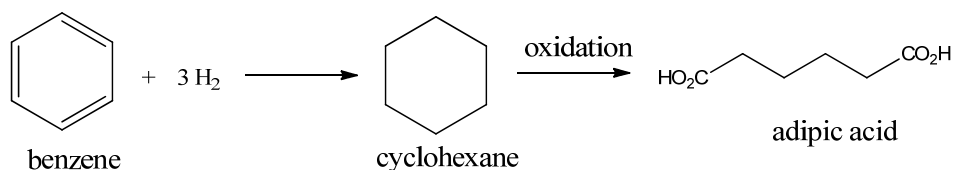

9.58

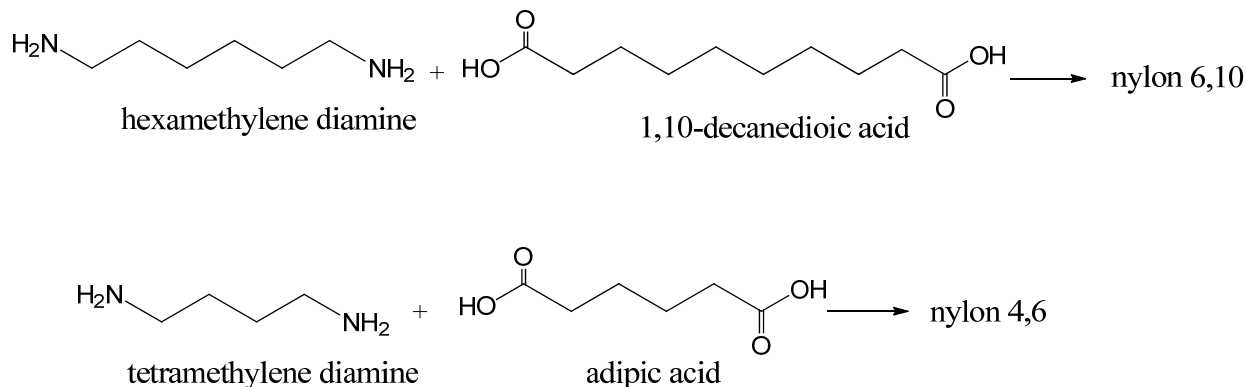

9.59

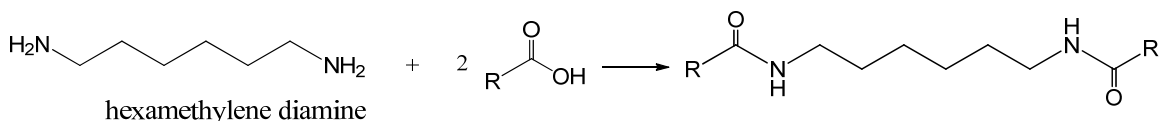

The monocarboxylic acid blocks the active amino sites therefore preventing growth of the polymer

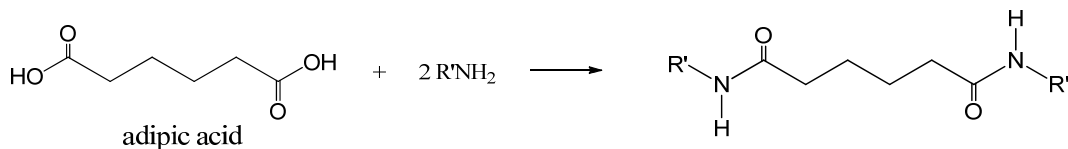

Parallel to the monocarboxylic acid, the monoamine blocks the carboxyl group therefore limiting the molecular weight of the growing chain.

9.60

(a) to exclude monocarboxylic acids and/or amines

(b) because a salt is involved, exactly equal amounts of both monomers are assured.

Both (a) and (b) are necessary for maximum molecular weight.

9.61

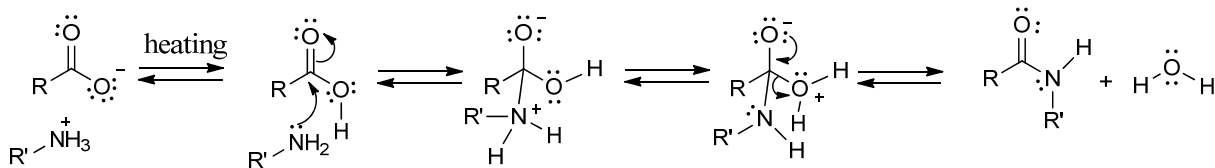

9.62

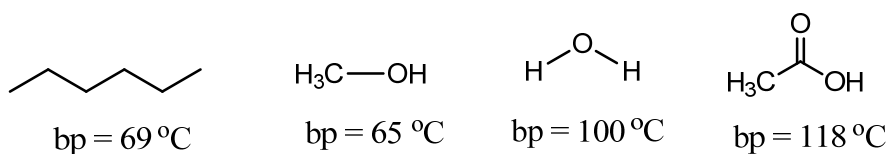

- Hydrocarbons are non polar molecules and would therefore boil at lower temperatures
- Methanol, water and acetic acid are polar and are suitable to form intermolecular hydrogen bonds. Their ability to form H-bonds increases from methanol to water to acetic acid. As a result:



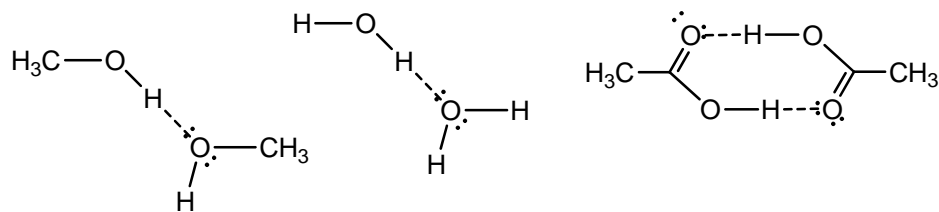

9.63

Yes. Because the lone pair of electrons of the oxygen atom is located in a  $sp^2$  orbital while  $-NH$  is in  $sp^3$  orientation. Therefore a geometrical alteration is required.

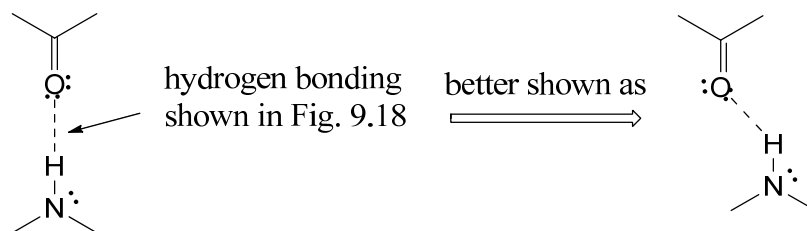

9.64

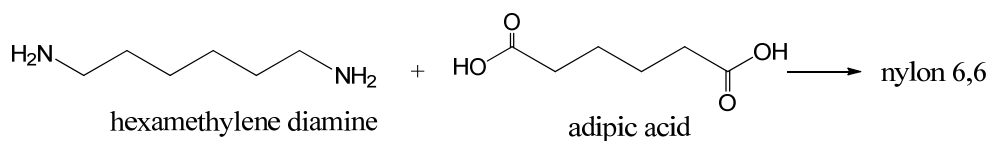
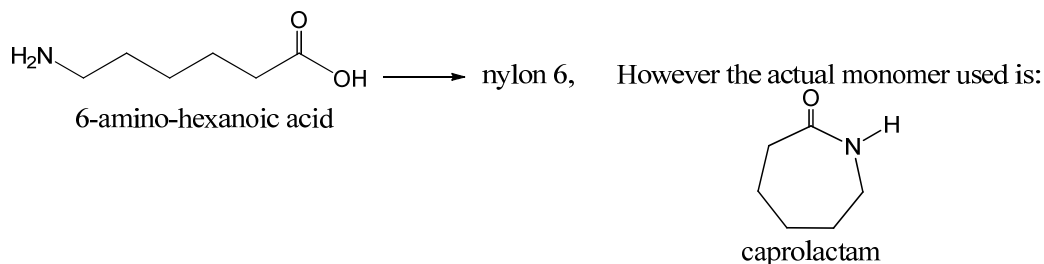

In nylon 6, both functional groups (amine and carboxylic acid) belong to the same monomer while in nylon 6,6, they are from two different monomers.

9.65

The statement is only approximately correct because it does not take into account the chain ends which should be added to the formula of the polymer. However, in very long chains the end group concentration is so low as to be ignored, which is also why the two isotactic polypropylenes in Fig. 9.10 cannot be distinguished.

## Chapter 10

### 10.1

A single molecule that could yield the polymer  $-(\text{HN}(\text{CH}_2)_5\text{CO})_n-$  (nylon 6) has the following structure:

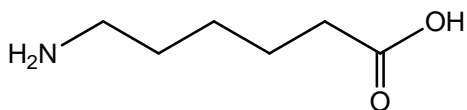

6-aminohexanoic acid  
(6-aminocaproic acid)

However the monomer used is caprolactam.

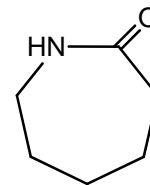

caprolactam

### 10.2

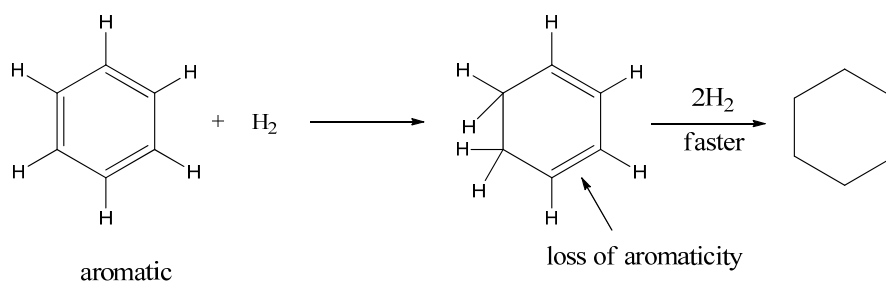

The delocalization of the  $\pi$ -electrons in benzene gives the molecule a special stability, aromaticity, which causes a higher energy price to break the  $\pi$ -system. Therefore, addition of the first molecule of  $\text{H}_2$  to a benzene ring is far more difficult than subsequent additions of the remaining two molecules of  $\text{H}_2$ .

### 10.3

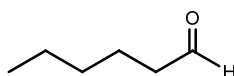

n-hexanal  
(aldehyde)

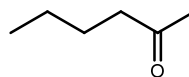

2-hexanone  
(ketone)

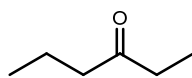

3-hexanone  
(ketone)

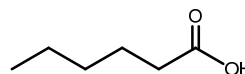

hexanoic acid  
(carboxylic acid)

10.4

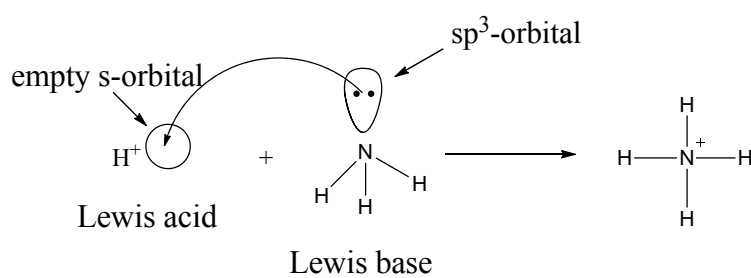
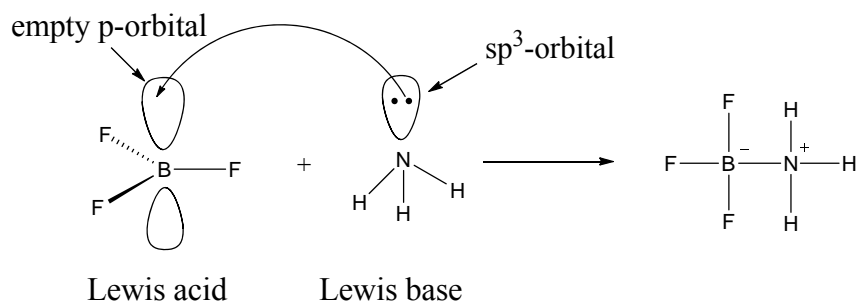

10.5

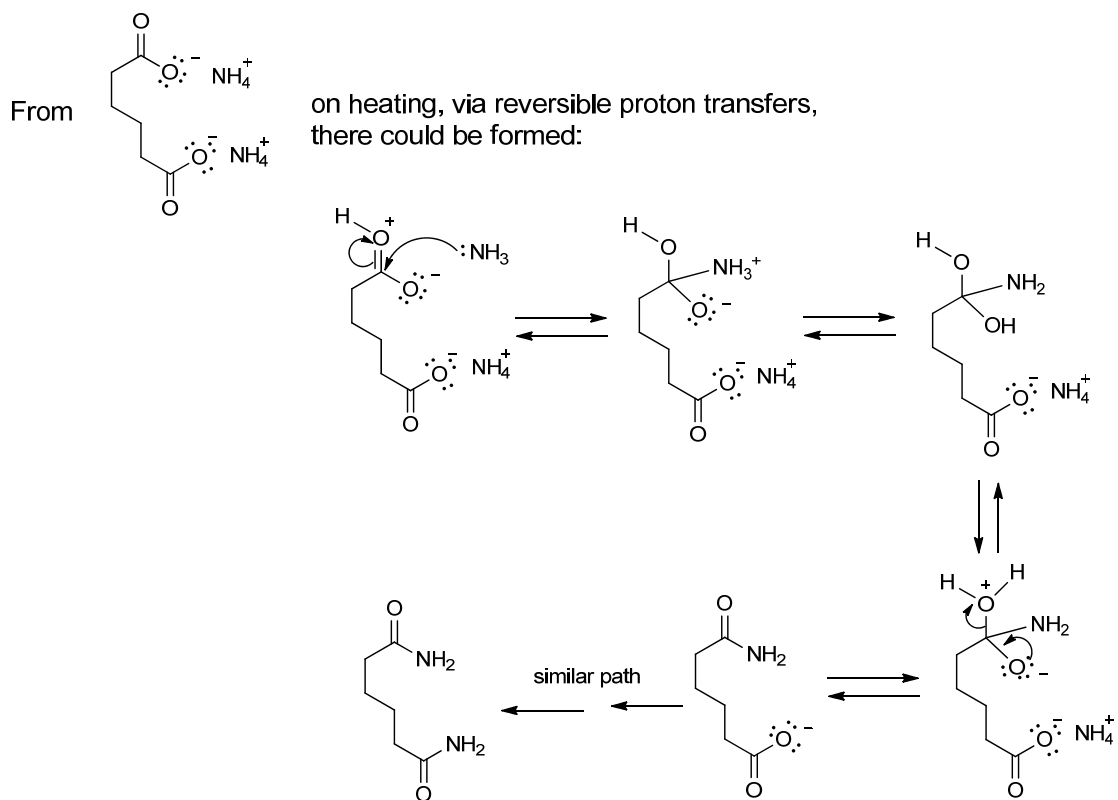

## 10.6

Both reactions are reductions which involve:

- (1) Transfer of hydride ions ( $\text{H}^-$ ) from the reducing agent (NADH or  $\text{LiAlH}_4$ ) to the entity to be reduced.

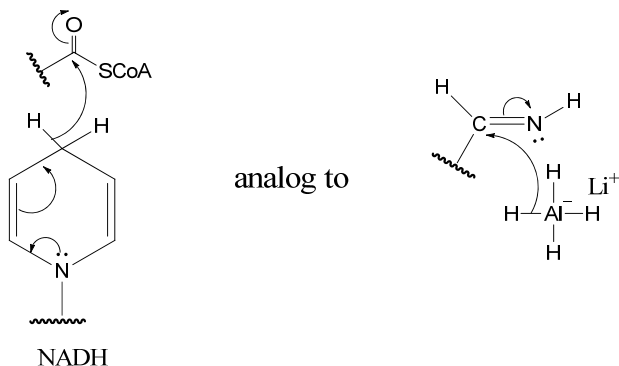

- (2) Addition of protons

## 10.7

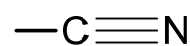
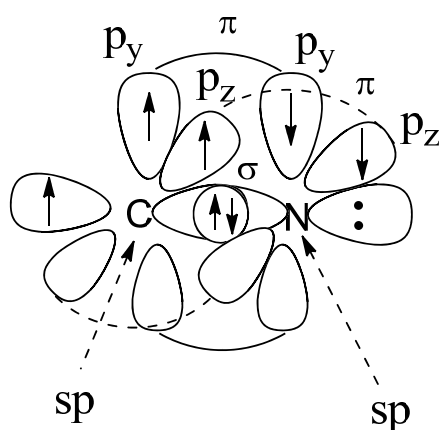

- hybridization:  $sp$
- geometry: linear
- one  $\sigma$ -bond C-N
- two  $\pi$ -bonds

## 10.8

The reaction of  $\text{LiAlH}_4$  with nitrile involves transfer of a pair of electrons from  $\text{AlH}_4^-$  (Lewis base) to the carbon atom of the nitrile group (Lewis acid). Therefore, this acid-base reaction belongs to the Lewis type.

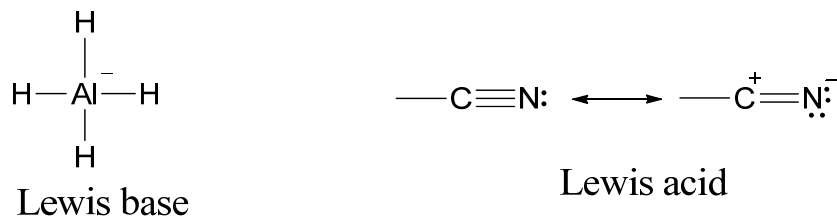

10.9

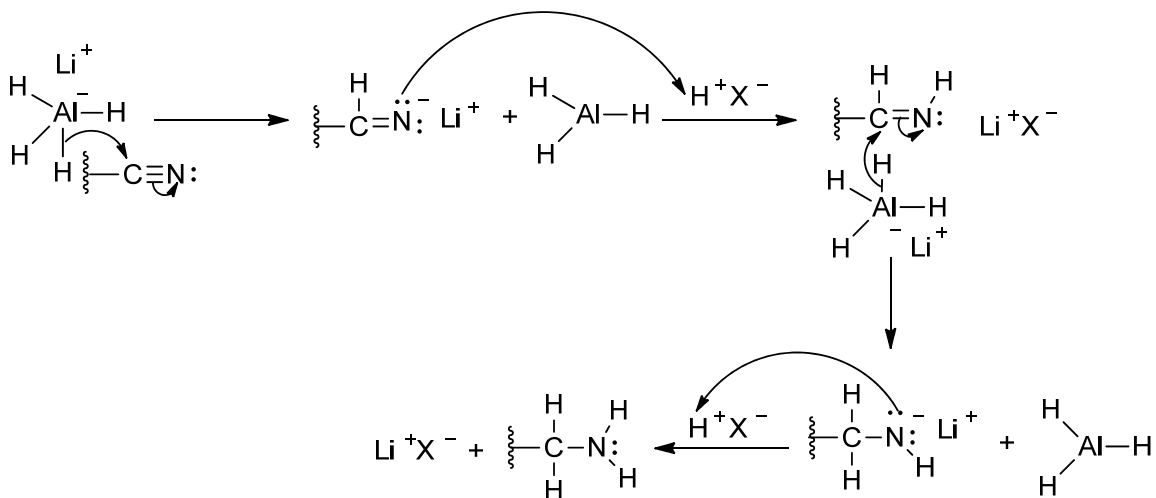

10.10

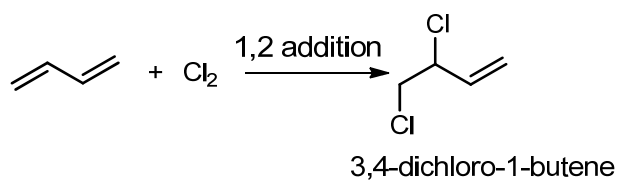

The product is obtained as two enantiomers. There is no stereochemistry for the second double bond.



10.11

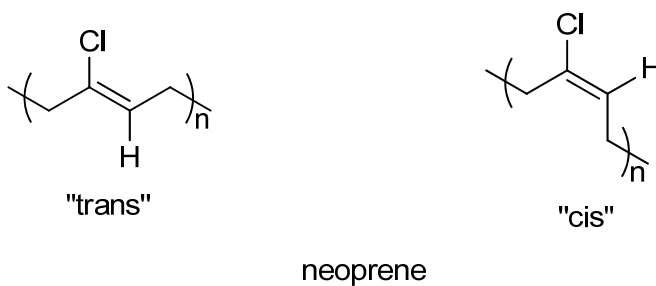

They are *configurational diastereomers*. A  $\pi$ -bond must be broken to interconvert these diastereomers.

10.12

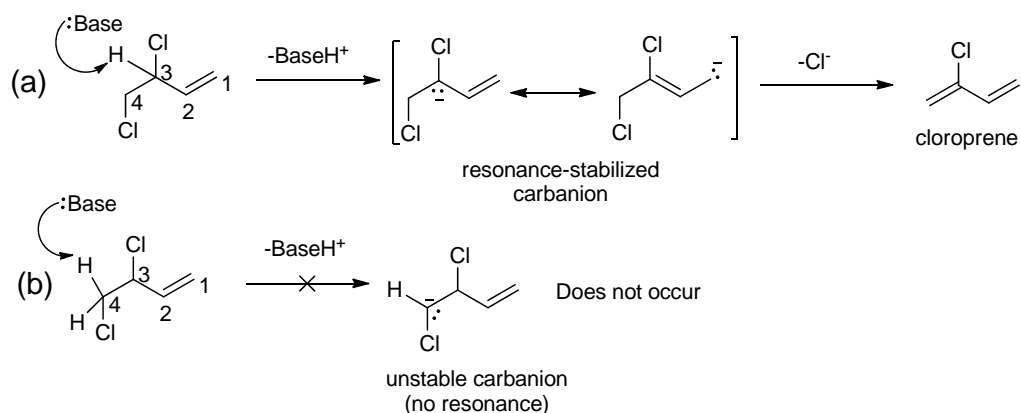

Loss of a proton at 3-position leads to a resonance-stabilized carbanion while abstraction of a proton at 4-position produces less stable carbanion.

10.13

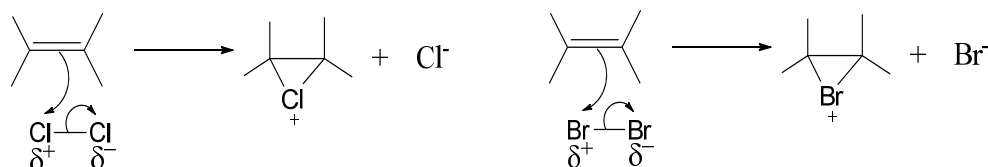

Yes. They can be considered as Lewis acid/base reactions between the double bond (Lewis base) and  $\text{Cl}_2$  or  $\text{Br}_2$  (Lewis acid).

Yes. Reactions in Figures 10.10 and 10.11 are reactions between electrophiles and nucleophiles.

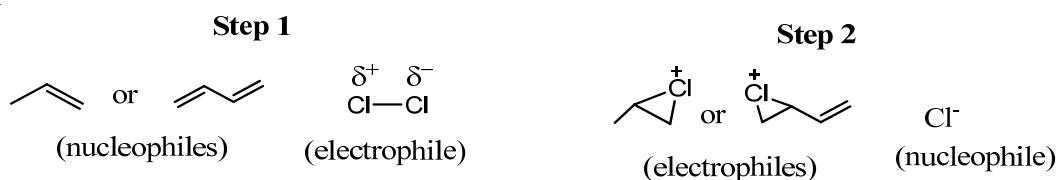

10.14

It reveals that the substitution of the carbocation site is more important than the substitution of the double bond.

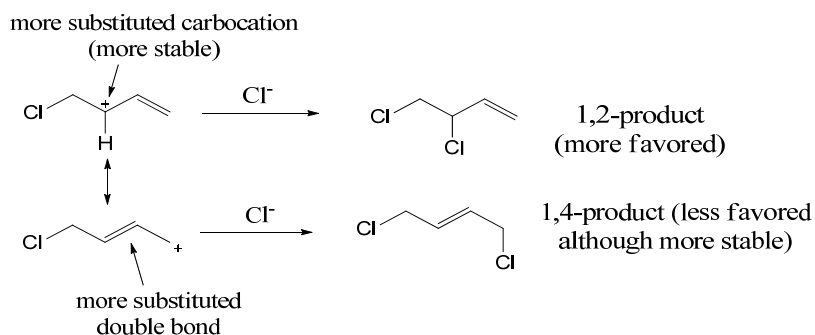



10.15

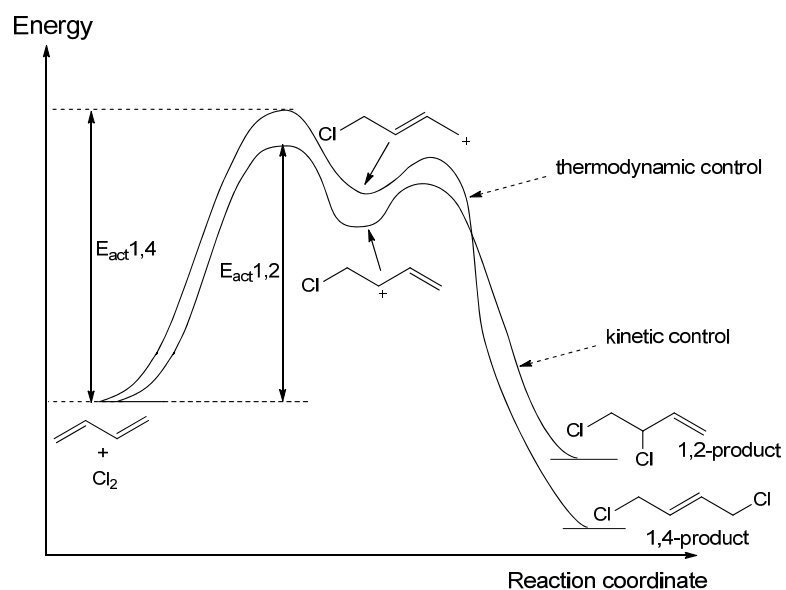

The two conflicting carbocations are:

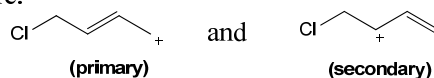

The more stable carbocation corresponds to the lower energy of activation (kinetically favored), but leads to formation of the less stable product (1,2-product).

10.16

Addition of chlorine to 1,3-butadiene is reversible, allowing an equilibrium state to be reached between 1,2- and 1,4-products. At higher temperatures, equilibrium is attained, allowing interconversion between the 1,2- and 1,4-products, which favors the more stable product (1,4-product), the more substituted alkene (thermodynamic control).

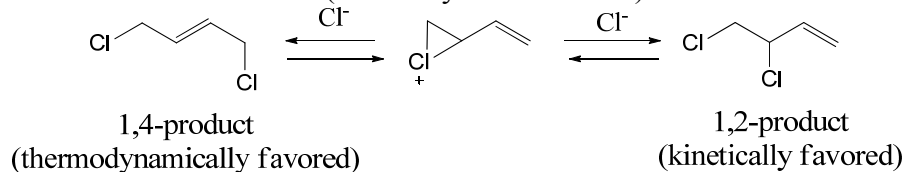

10.17

The DuPont process of addition of chlorine to 1,3-butadiene, was designed to occur near 200° C allowing the equilibrium state to be reached. Unfortunately, the stability of the 1,4-product (1,4-dichloro-2-butene) is not so much greater than the 1,2 product (3,4-dichloro-1-butene) as to exclude the latter from the equilibrium mixture. However, the 1,4-product and the 1,2-product boil at 155° C and 123° C, respectively; which are far enough apart to separate the 1,2-product by fractional distillation, leaving the 1,4-product in the pot.

A copper catalyst, able to interconvert the two isomeric 1,2- and 1,4-products, was also found and could be added to the distillation mixture if the 1,2-product was desired. In this case, although, the 1,4-product is thermodynamically favored, the lower boiling 1,2-product was continuously removed so that, eventually, all the 1,4-product was converted to the 1,2-product.

10.18

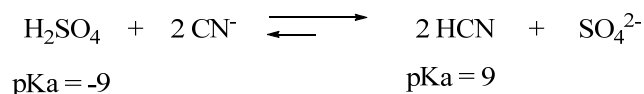

$\text{H}_2\text{SO}_4$  is a stronger acid than HCN. Therefore, the equilibrium is shifted to the right, leading to successful production of HCN from  $\text{H}_2\text{SO}_4$ .  $\text{H}_2\text{SO}_4$  could not be therefore produced from HCN and sulfate anion.

10.19

1,2-addition involves the more substituted carbocation (kinetically favored). Therefore, the 1,2-product is more favored than the 1,4-product although the latter contains the more substituted double bond.

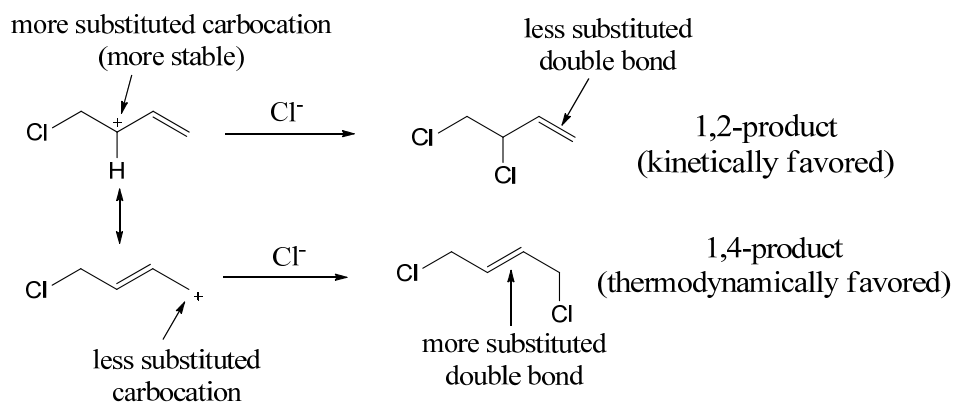

10.20

The statement is based on the fact that a copper catalyst was able to completely convert a mixture of 1,2- and 1,4-dicyanopropenes to 1,4-product, while in the case of dichloropropenes, the catalyst was found to interconvert the two isomers, therefore suggesting that 1,4-dicyanopropene was more stable than 1,4-dichloropropene.

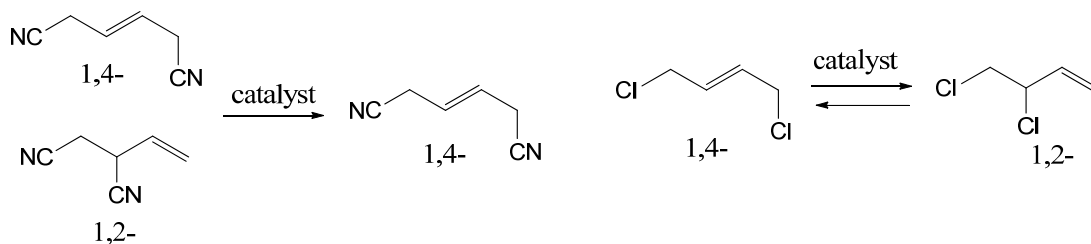

10.21

The energy of activation (as seen in Fig. 10.13) of step 2 (reaction of the carbocation with the double bond) and step 3 (loss of a proton) are far lower than the energy of activation of step 1, the formation of carbocation. This step will be therefore the “rate determining” step (the slowest step).

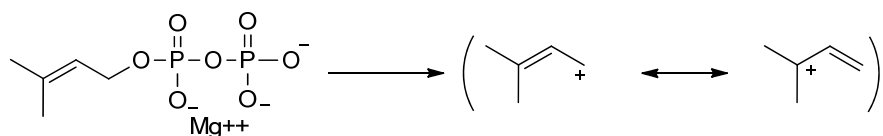

10.22

Let's do it for some of the structures.

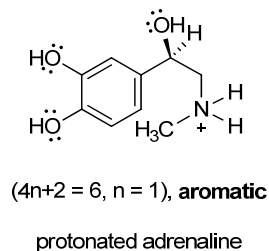
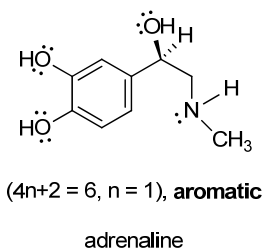
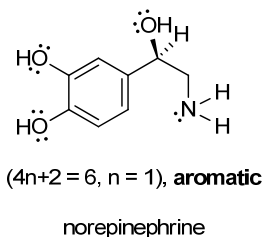
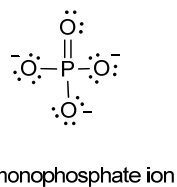
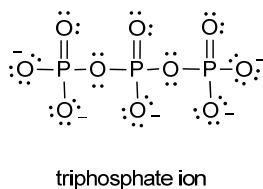
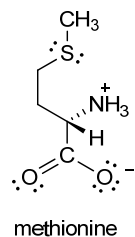
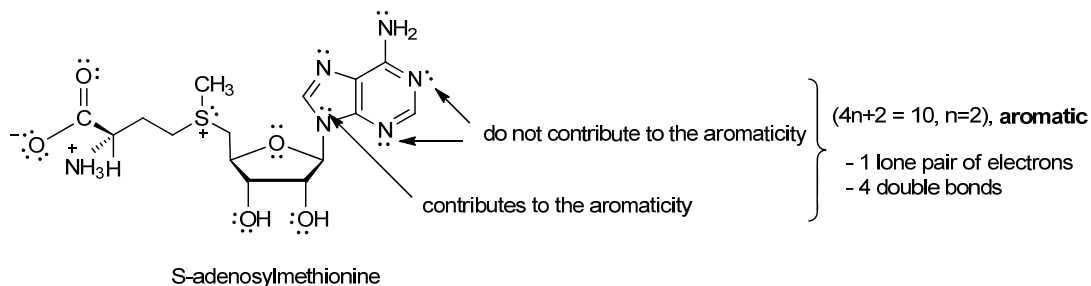

10.23

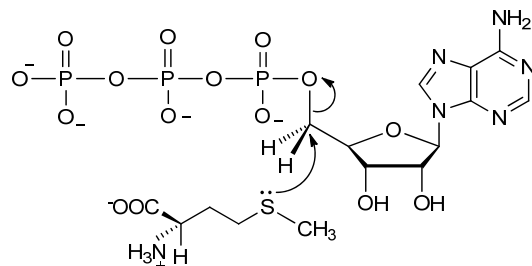

The carbon atom, site of nucleophilic substitution, is a  $\text{CH}_2$  group (primary) and is not conjugated to a double bond. Therefore, the reaction requires  $\text{S}_{\text{N}}2$  mechanism. In other words, an  $\text{S}_{\text{N}}1$  mechanism would have involved the formation of a primary carbocation, which is highly unstable and thus less likely to form.

## 10.24

Because a carbocation that might be formed through  $S_N1$  mechanism would have been less stable in a low dielectric solvent (less ionizing solvent) such as dichloromethane, benzene, etc. Therefore, a less polar solvent will favor the  $S_N2$  mechanism.

## 10.25

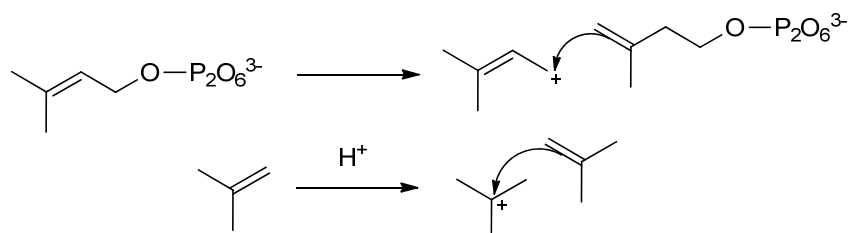

Intermediate carbocation adds to a double bond in both

## 10.26

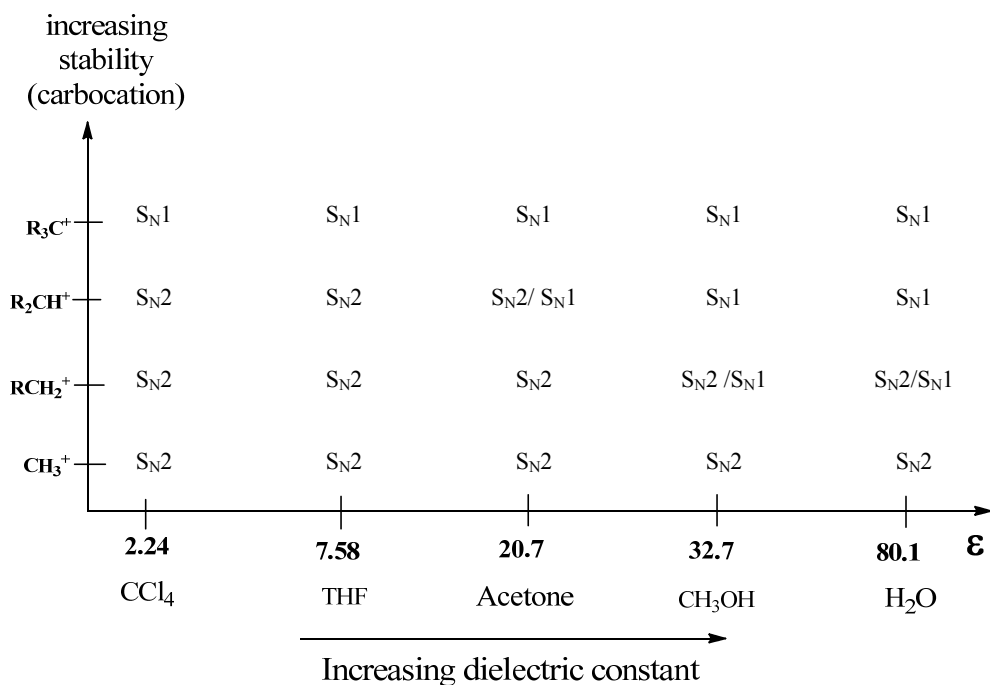

## 10.27

The  $Mg^{++}$  counterion increases the leaving group propensity of the  $P_2O_7^{4-}$  therefore favoring  $S_N1$  mechanism. In the absence of  $Mg^{++}$ ,  $S_N2$  would be more favorable.

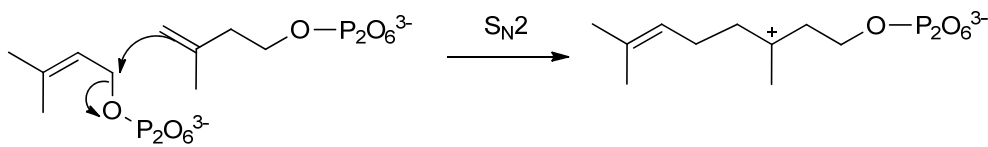

10.28

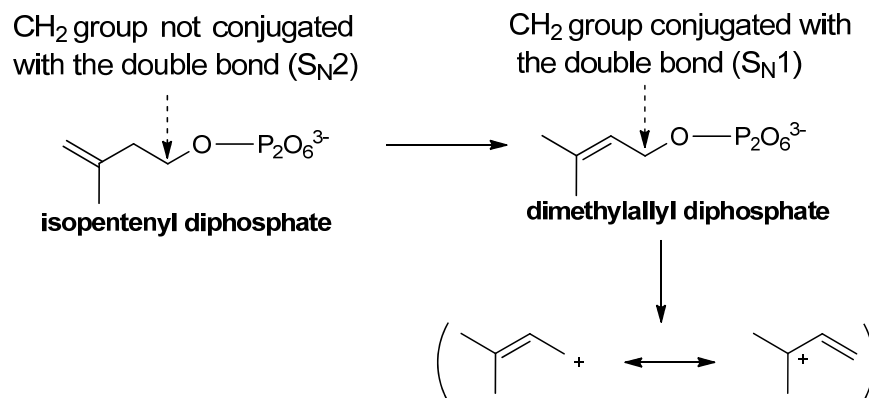

In isopentenyl diphosphate, the site of nucleophilic substitution, a CH<sub>2</sub> group, is primary and not conjugated with the double bond. Therefore, it would point to nucleophilic substitution via S<sub>N</sub>2 mechanism; whereas, in dimethylallyl diphosphate, the CH<sub>2</sub> group is conjugated with the double bond which would favor the formation of a resonance-stabilized carbocation, therefore pointing to a substitution via S<sub>N</sub>1 mechanism.

10.29

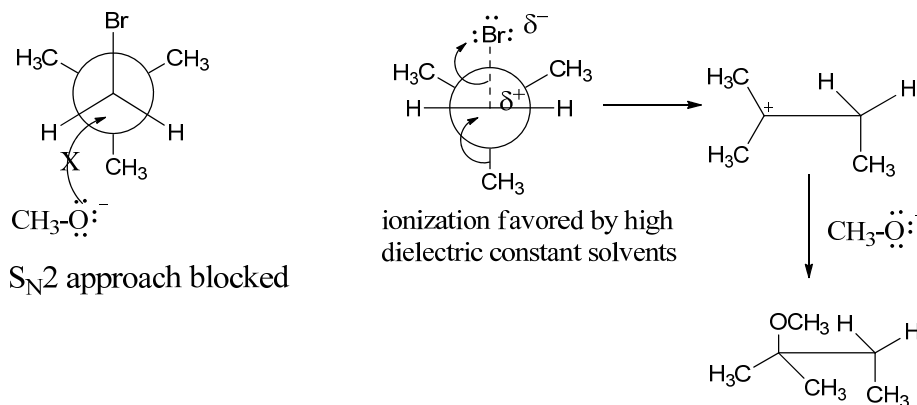

10.30

Sterically bulky nucleophiles such as (CH<sub>3</sub>)<sub>3</sub>C-O<sup>-</sup> disfavor the nucleophilic substitution via S<sub>N</sub>2 mechanism because large nucleophiles will have a difficult time in getting close enough to the substrate.

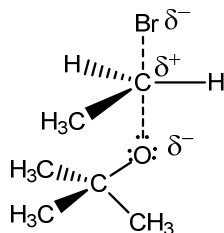

Steric hindrance arising from the structure of the attacking nucleophile even for a primary reaction site as shown here.

## 10.31

Looking at the stereochemistry of the starting substrate and the final product, it appears that there is an inversion of the configuration of the carbon atom site of nucleophilic substitution. Therefore, reaction 1 (Fig. 10.21) occurs via the  $S_N2$  mechanism.

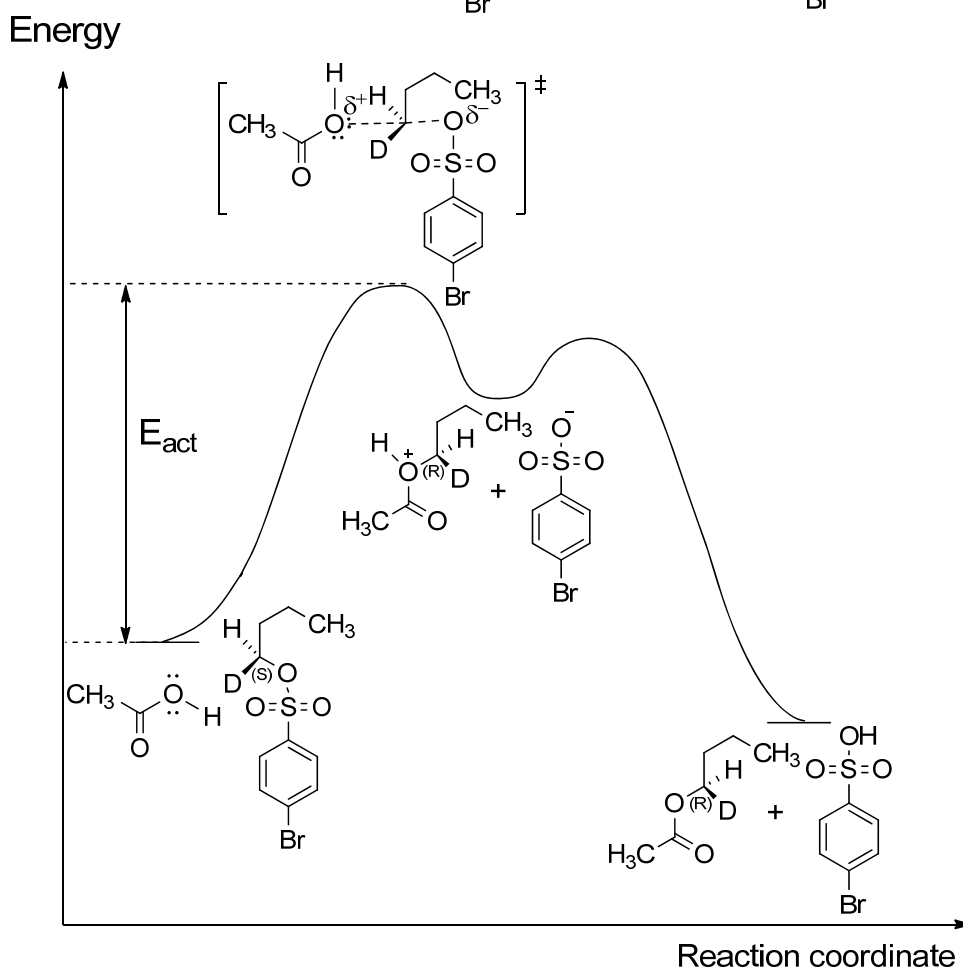
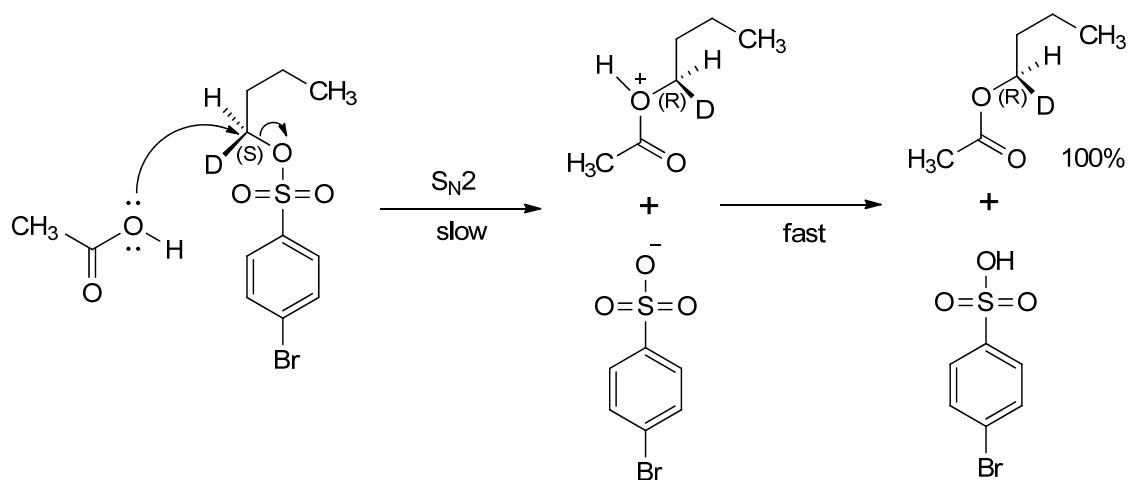

## 10.32

The carbon atom, site of nucleophilic substitution, is tertiary and conjugated with the aromatic ring. Therefore, the formation of a resonance-stabilized carbocation is strongly favored. The reaction would then occur via the  $S_N1$  mechanism leading to a nearly racemic mixture due to the enantiotopic character of both faces of the carbocation.

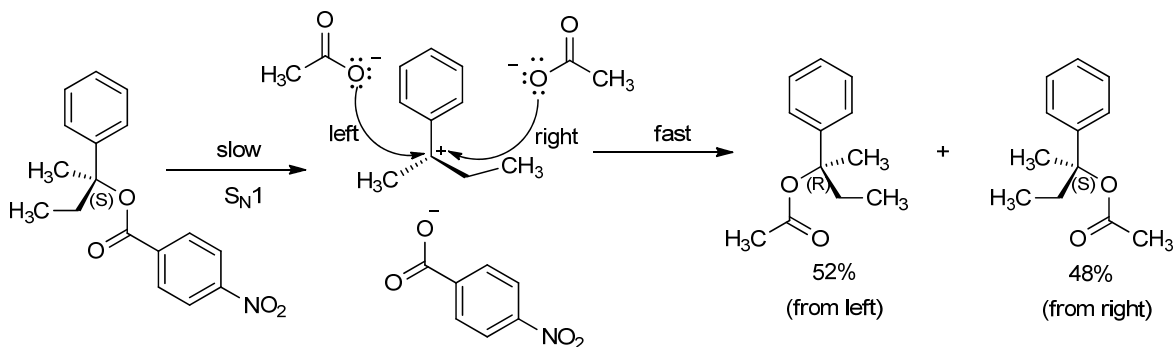

An exact racemic mixture (50:50) is not obtained because the release of the leaving group slows down the attack of the nucleophile from the face where the leaving group is released.

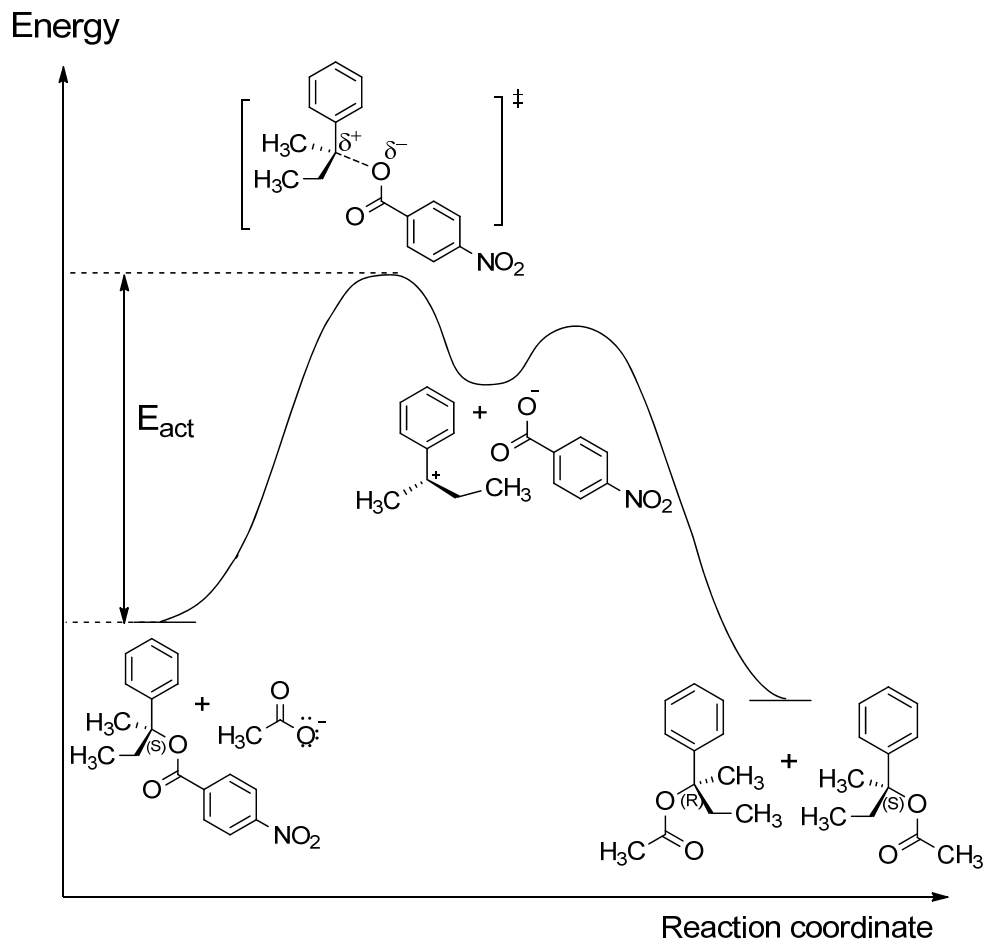

## 10.33

In the second product (12%), the configuration (S) of the carbon atom site of nucleophilic substitution is preserved. This product is one of the two enantiomers formed via the  $S_N1$  mechanism (racemic mixture). Assuming that both faces of the intermediate carbocation are ideally enantiotopic, the enantiomer (R) of the 12% product is the same product as the one obtained via the  $S_N2$  mechanism (inversion of configuration), which is the 88% product. As a result:

$S_N1$ : 12% (S) + 12% (R) = 24% (racemic mixture)

$S_N2$ : 88% (R) – 12% (R) from the  $S_N1$  mechanism = 76% (R)

## 10.34

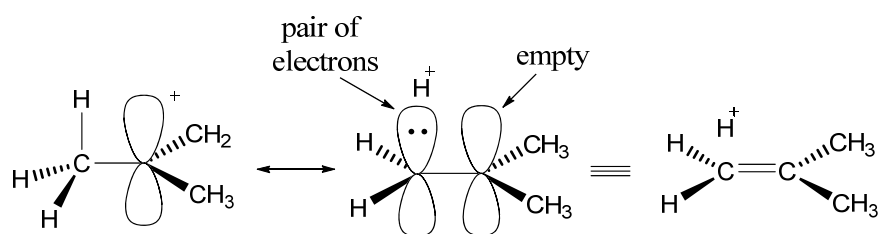

Hyperconjugation

## 10.35

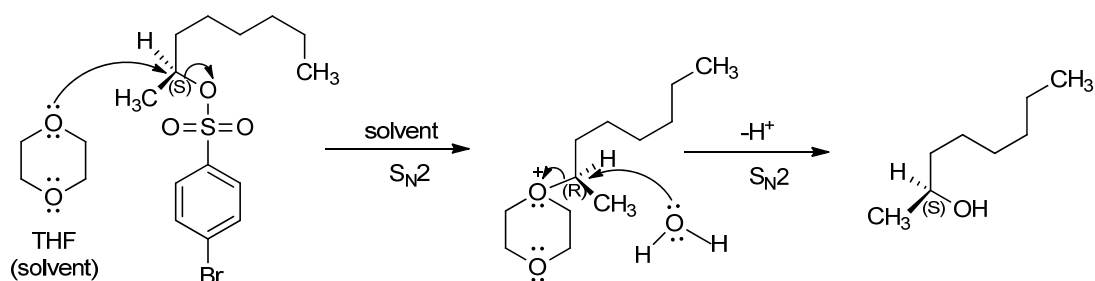

Double inversion of configuration = retention of configuration

## 10.36

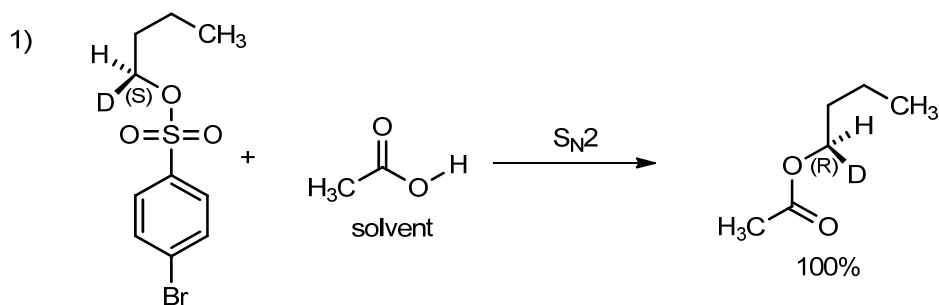



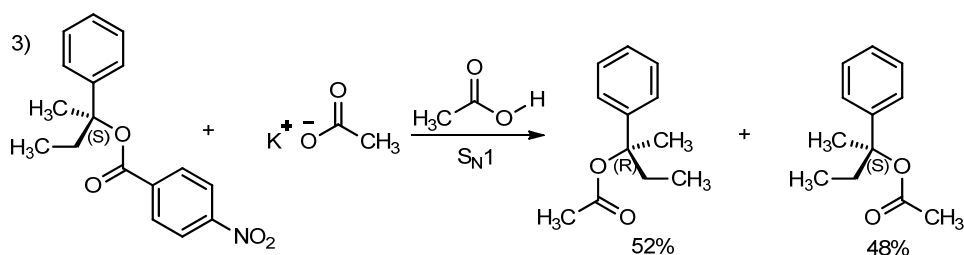
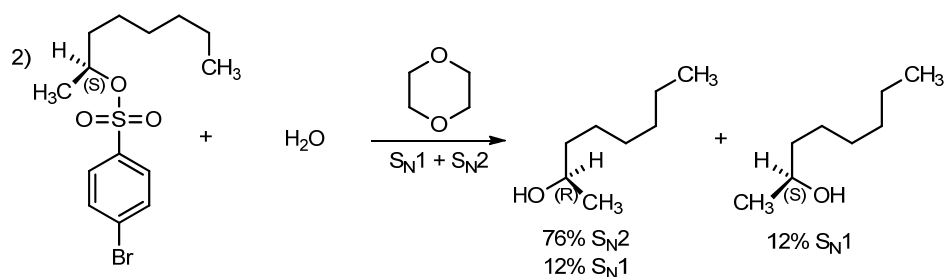

The  $S_N2$  reaction always involves inversion of configuration at the site of substitution, however, there are examples where the CIP nomenclature does not switch between (R) and (S). Here is one:

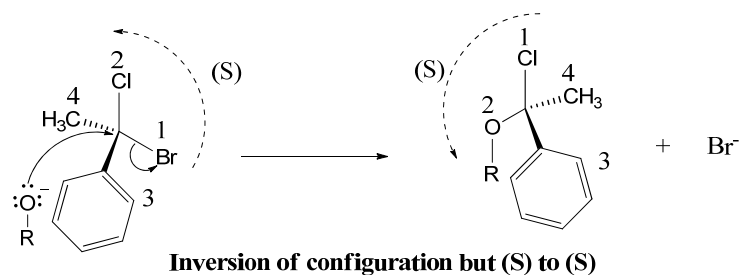

10.37

(a) for 1,4-product:

Both carbon atom sites of nucleophilic substitution are  $CH_2$  groups conjugated with the double bond. Therefore, depending on the experimental conditions, both  $S_N1$  and  $S_N2$  can be predicted with  $S_N1$  favored in polar solvents.

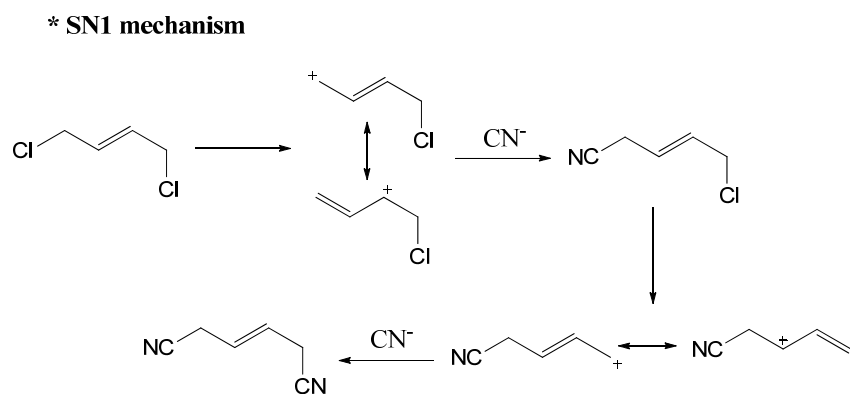

\* S<sub>N</sub>2 mechanism

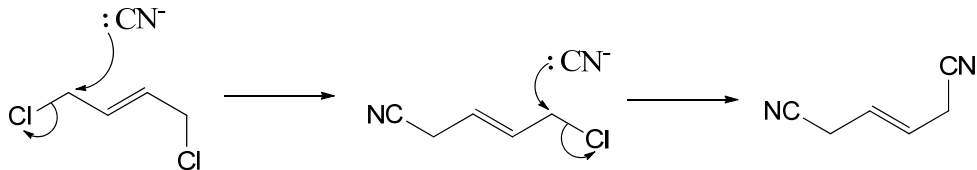

(b) for 1,2-product:

Of the two carbon atom sites of nucleophilic substitution, one is primary (CH<sub>2</sub>), not conjugated with the double bond therefore pointing to the S<sub>N</sub>2 mechanism. The other is secondary (CH), conjugated with the double bond and the substitution would occur via the S<sub>N</sub>1 mechanism.

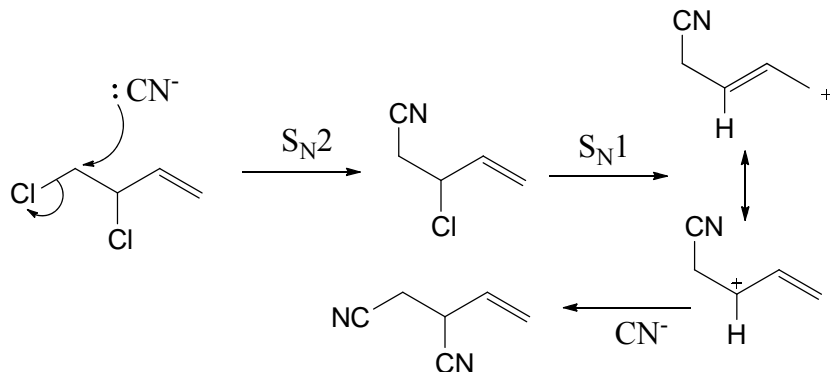

## Chapter 11

### 11.1

The branches in LDPE do not allow close packing of the hydrocarbon chains and therefore retard crystallization. The “cis (Z)” double bonds in unsaturated fatty acids play the same role, as do the “cis” double bonds in Hevea rubber. Look ahead to Fig. 11.5. The “trans” double bonds in Gutta percha allow close packing and crystallization and therefore chain inflexibility: elastic properties become impossible.

### 11.2

Yes. They do obey the isoprene rule.

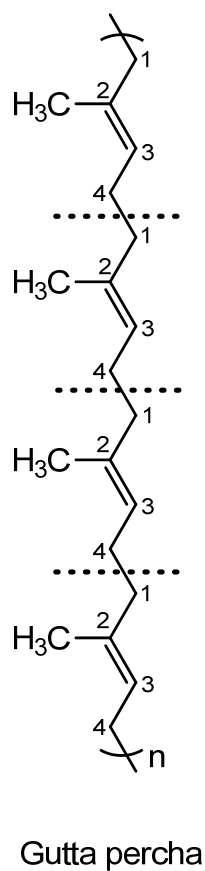
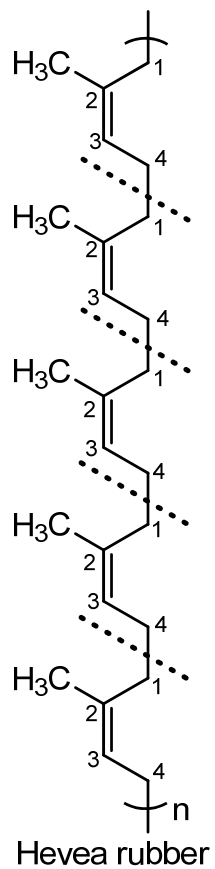

### 11.3

The energy of activation in cis-trans isomerization is the energy barrier required for interconversion between “cis” and “trans” double bonds, which is too high and becomes more accessible as the temperature increases, as reported in Fig. 6.15.

11.4

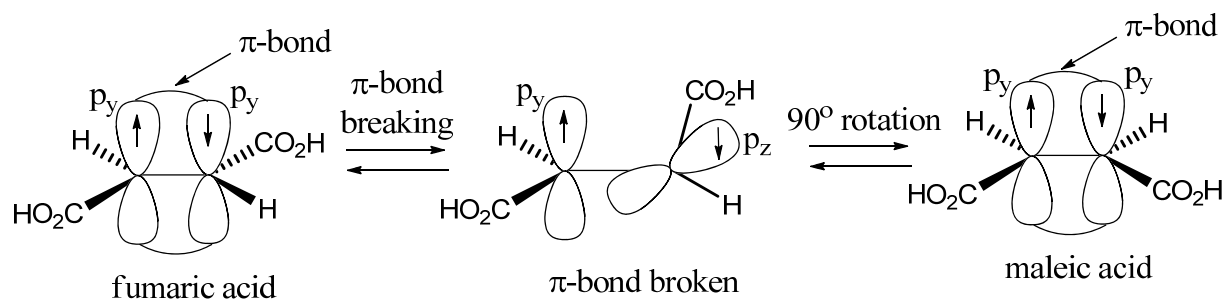

11.5

No. Flipping of the cyclohexane ring switches axial-positions to equatorial-positions and vice-versa. Therefore, :cis" and "trans" configurations remain unaltered.

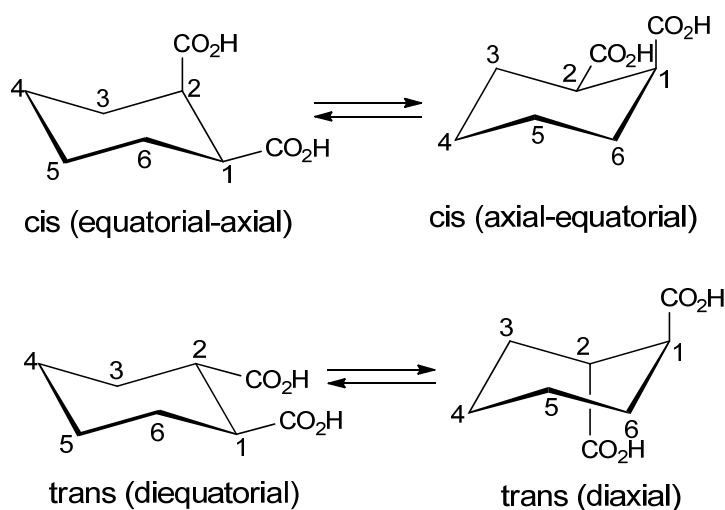

11.6

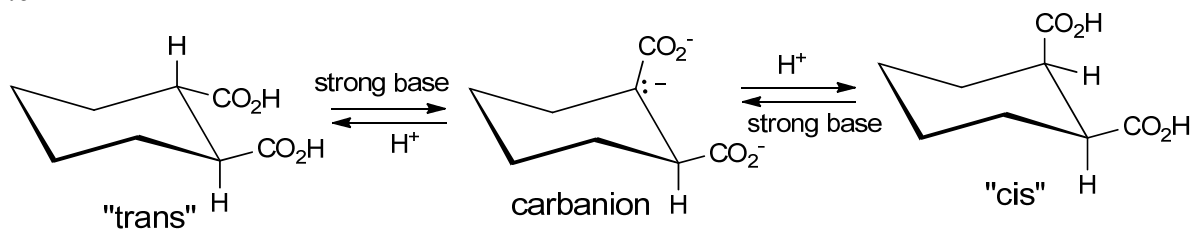

The carbanions formed in the presence of a strong base, can interconvert via a planar transition state and addition of a proton would occur to either face leading to cis-trans isomerization.

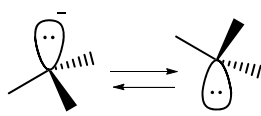

## 11.7

As tartaric acid, both isomers (cis and trans) have two identical chiral carbon atoms in adjacent positions. Cis-isomer is analogous to *meso*-tartaric acid although there is no plane of symmetry (the cyclohexane ring is not flat); while the trans-isomer is analogous to the other diastereomer which is present as a pair of enantiomers.

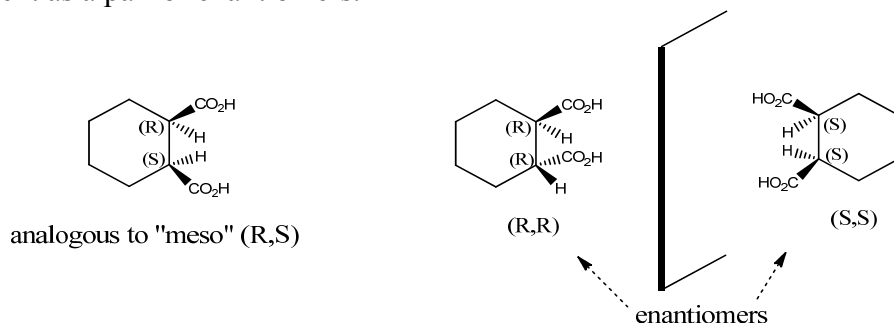

## 11.8

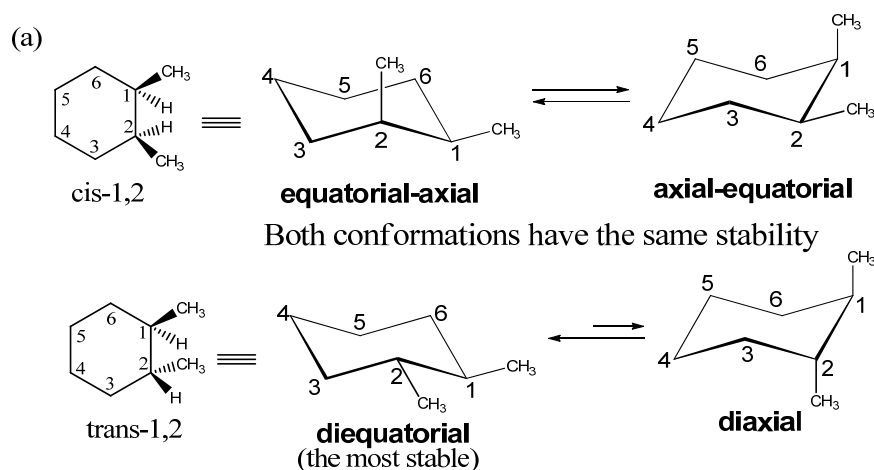

Trans-1,2 diequatorial is the most stable because both CH<sub>3</sub> groups occupy equatorial positions.

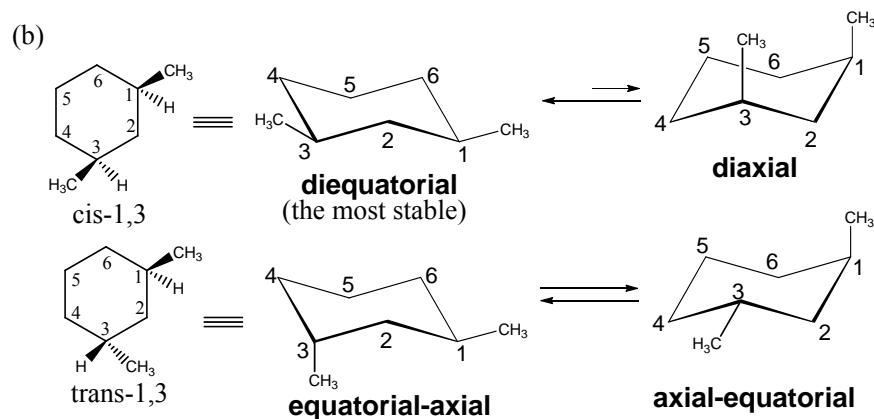

Both conformations have identical stability

Cis-1,3 diequatorial is the most stable conformation.

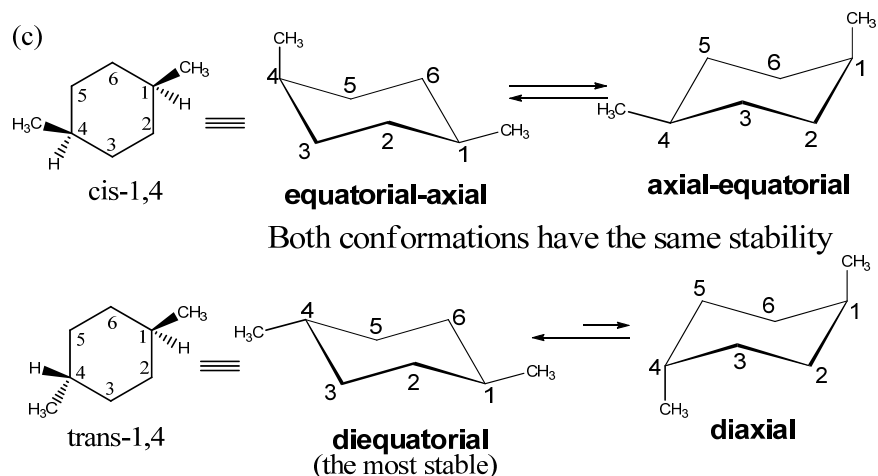

Trans-1,4 equatorial is the most stable conformation.

Cis- and trans-1,4 are achiral, as is cis-1,3. Trans-1,3 is chiral, as are trans- and cis-1,2. However, while ring flipping of either enantiomer of trans-1,3 causes no racemization (and in fact no change in structure), ring flipping of cis-1,2 causes racemization. Ring flipping of trans-1,2, while not causing racemization does change the structure.

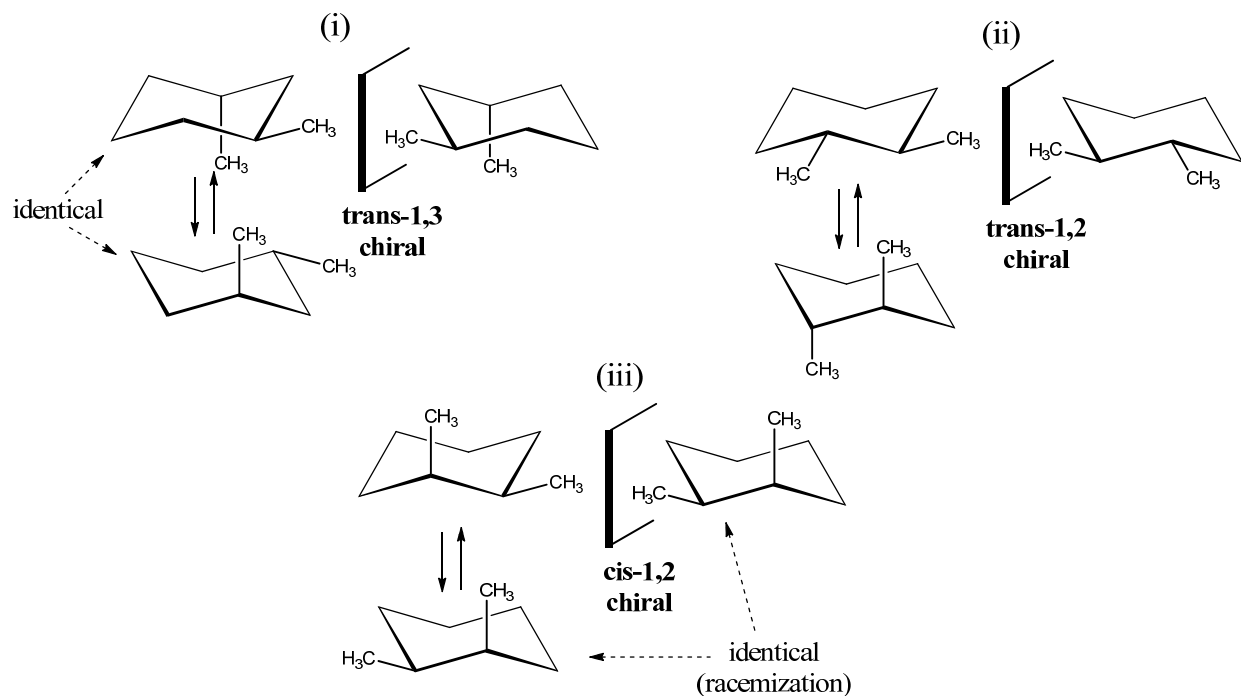

## 11.9

The elastic property of natural rubber makes it valuable for airplane tires because it is more resilient than any synthetic rubber ever produced and therefore stays cooler.

11.10

LDPE, (cis)-unsaturated fatty acids and atactic (random) polypropylene are good candidates for elastomeric properties because of the difficulty of their chains to pack together closely. The close packing, as in HDPE and in saturated fatty acids causes restriction to both conformational motion and to the movement of the chains relative to each other.

11.11

Only few conformational changes can cause large changes in the overall shape of a chain.

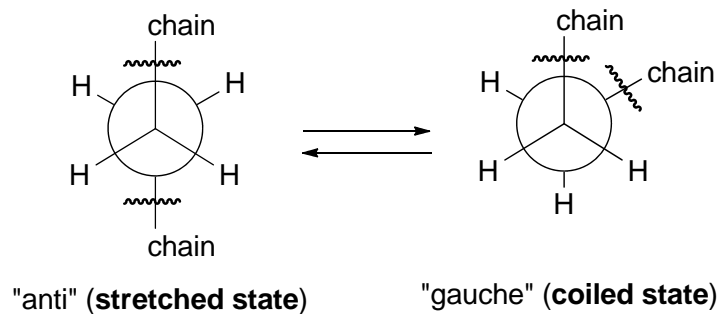

11.12

Joule and Carnot formulate the so-called "first" and "second" laws of thermodynamics from which it came to be understood that work can be expressed as heat. Stretching an elastomer involves work.

11.13

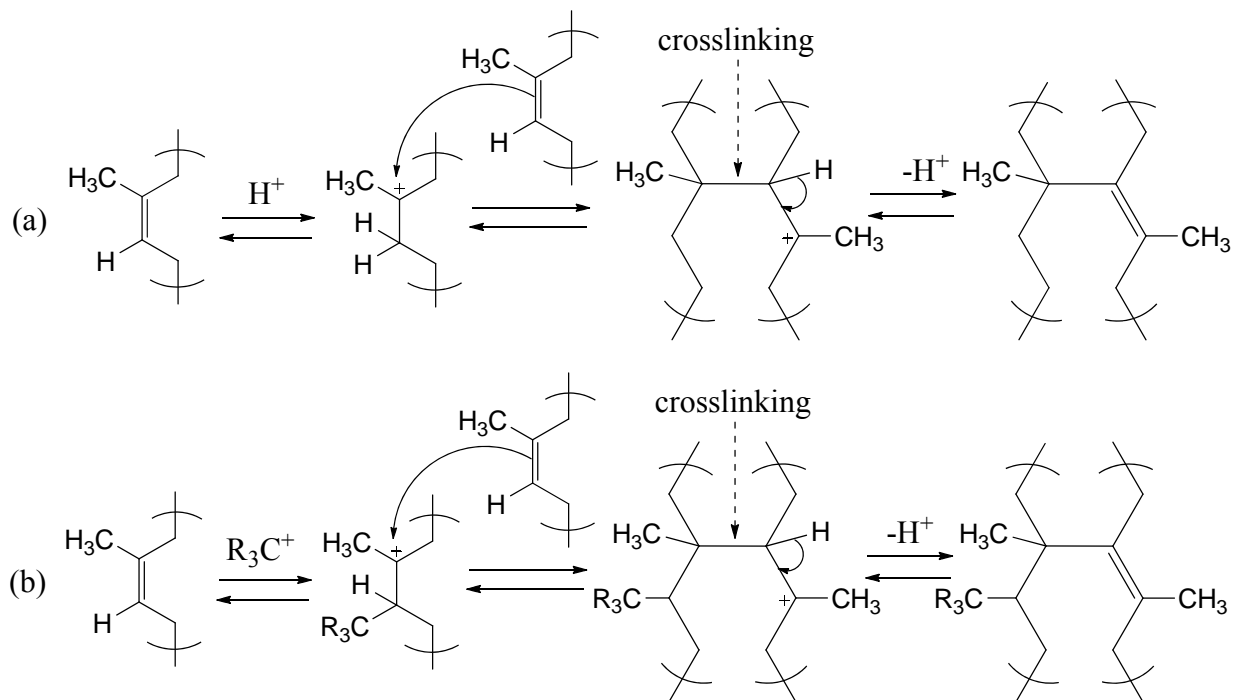

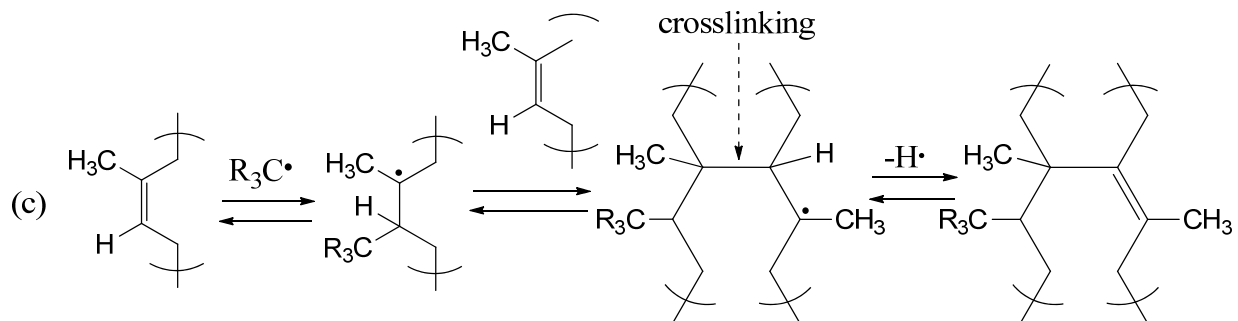

11.14

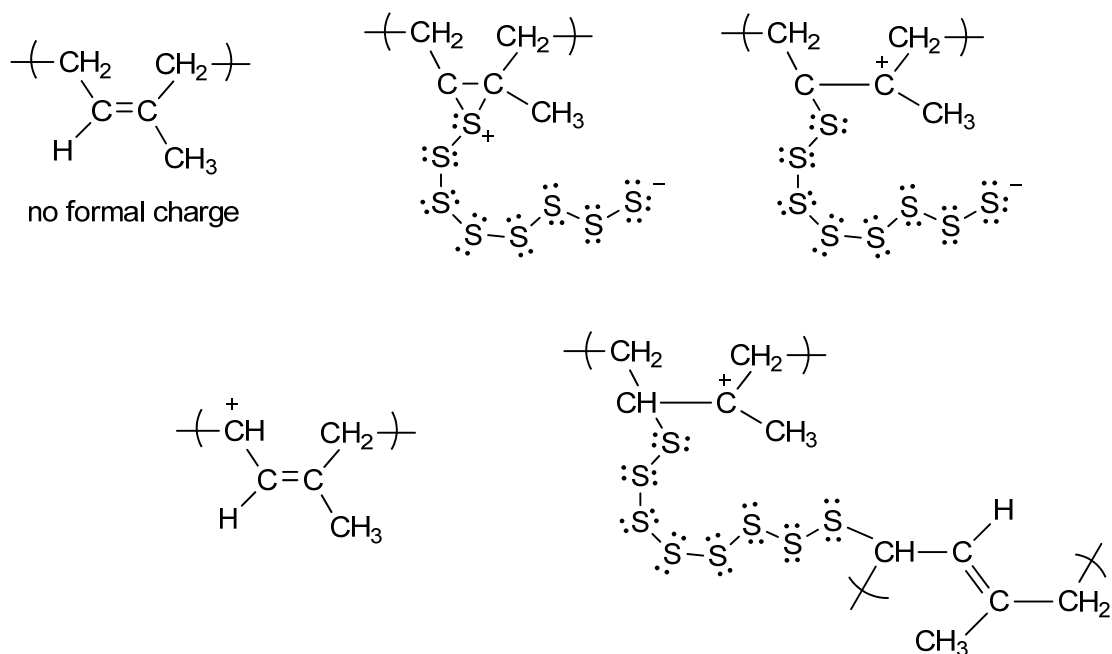

11.15

The puckered ring conformation of  $S_8$  allows an approximate tetrahedral angle for the S atoms and reduces eclipsing overlap of the two lone pairs of electrons on each S atom, a torsional strain.

11.16

The attack from above would invert the configuration of the chiral center.

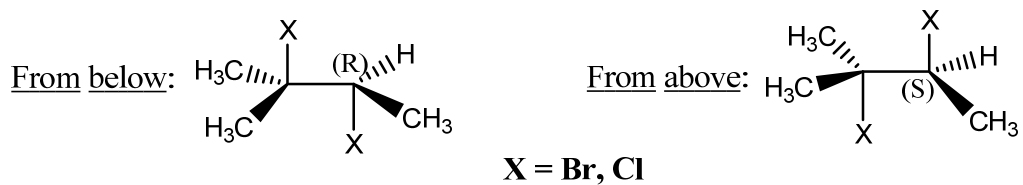



11.17

Yes. The opened form of S8 involves a large number of conformations. Therefore, a change from opened form to closed ring form causes a loss of entropy ( $\Delta S < 0$ ). Lower the temperature would therefore help the ring closing.

11.18

(a) initiation steps

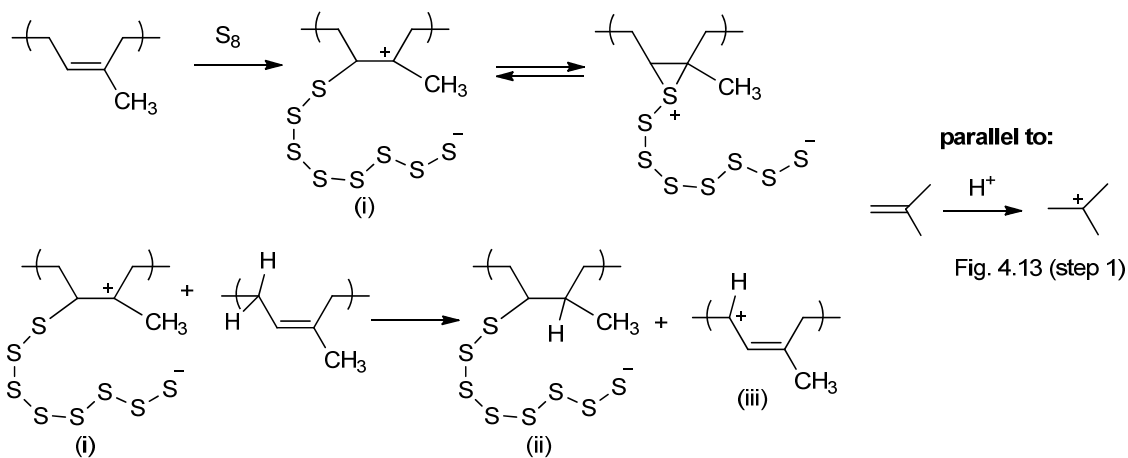

(b) propagation steps

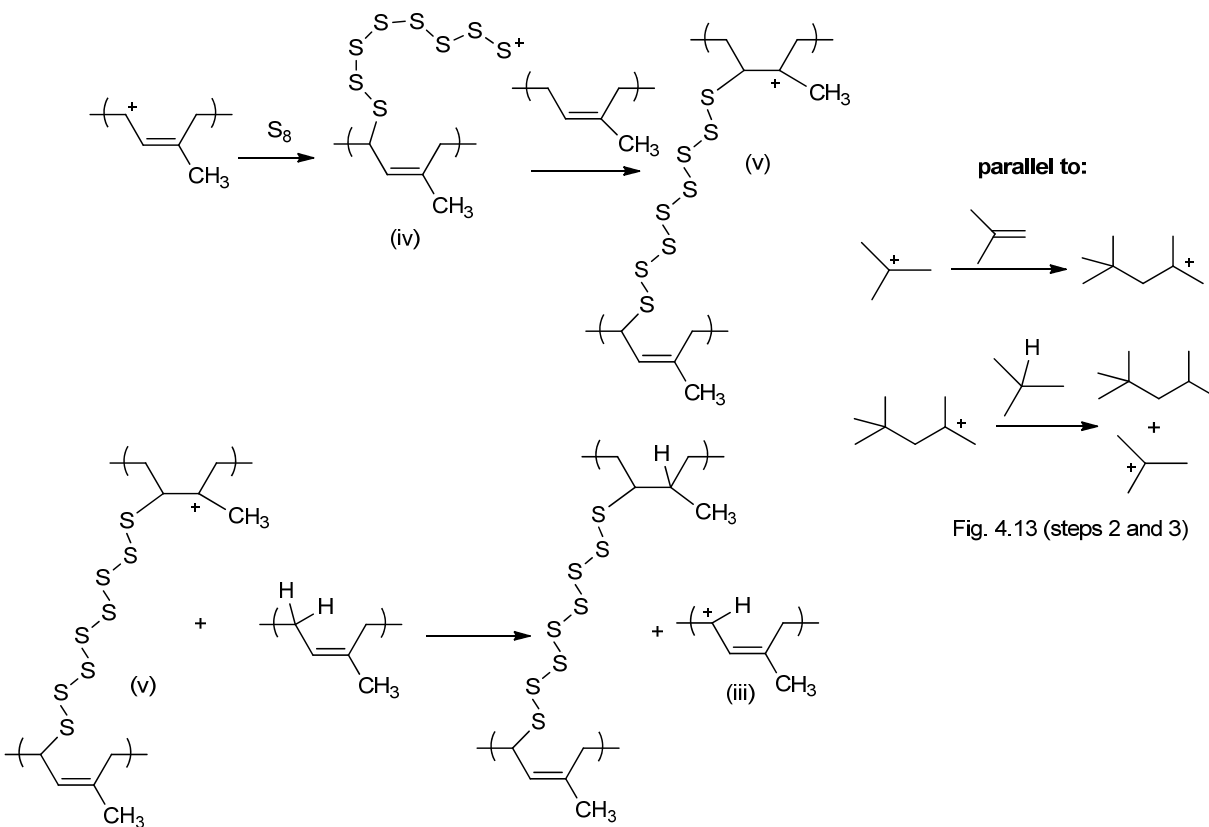

(c) termination steps

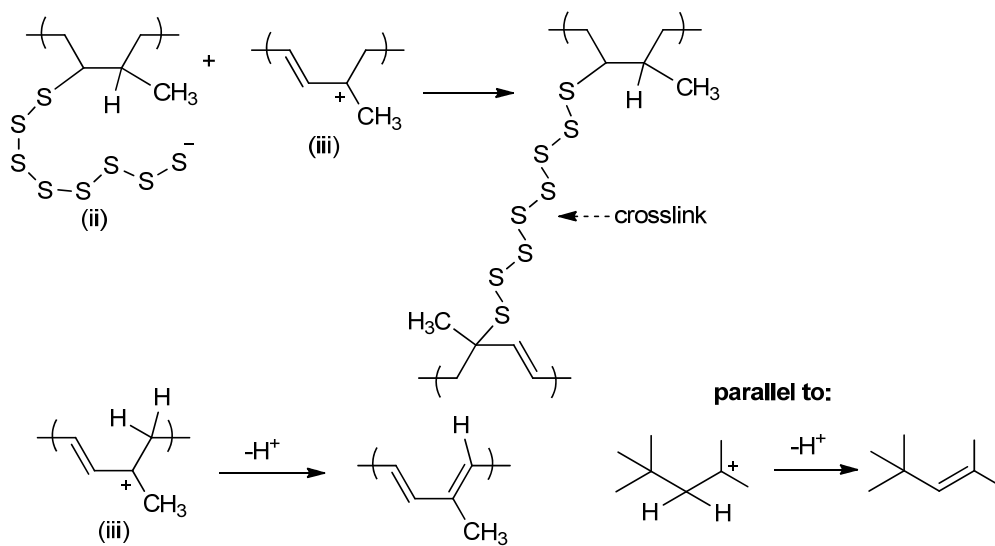

11.19

**1) Catalytic cracking and synthesis of "high octane" gasoline**

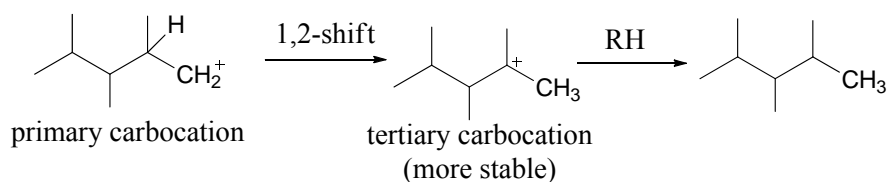

**2) Markovnikov's rule**

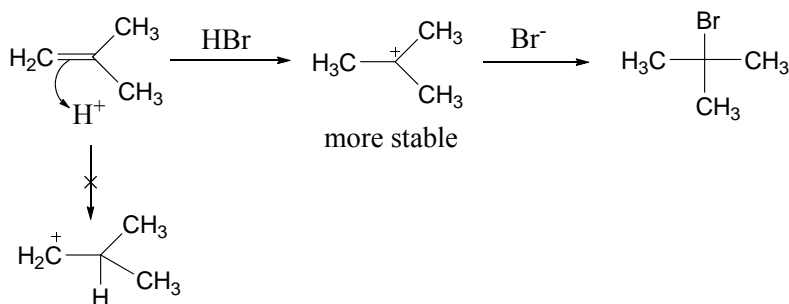

**3) Terpenes formation**

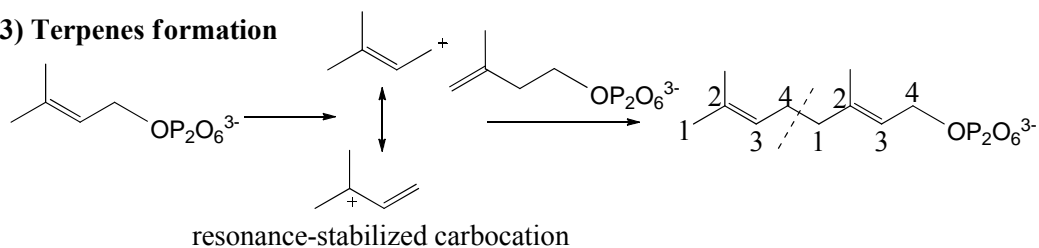

#### 4) Electrophilic aromatic substitution

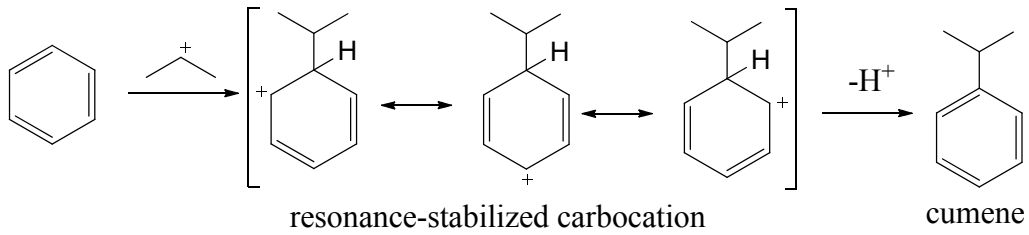

#### 5) Competition between nucleophilic substitution mechanisms

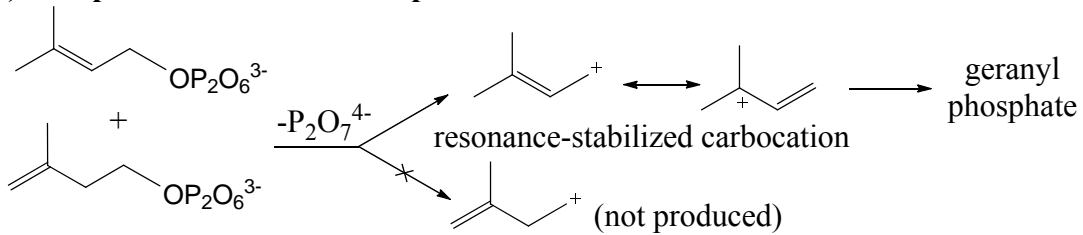

11.20

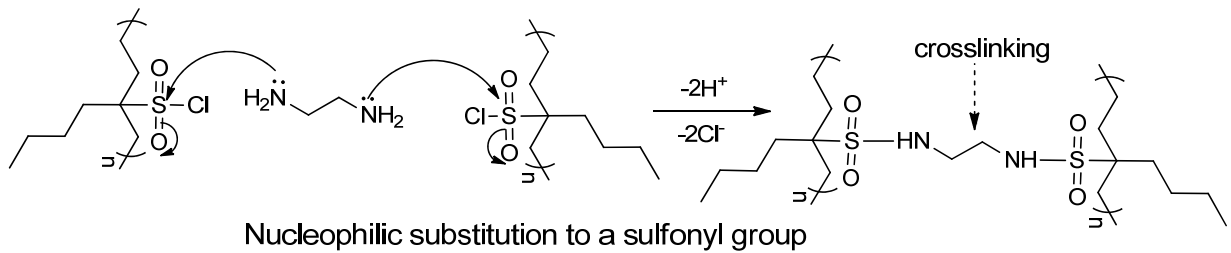

11.21

Cl—Cl: high energy bond (weak bond)      C—C } low energy bonds (strong bonds)  
 $\pi$ -bond: high energy bond (weak bond)      C—H }

11.22

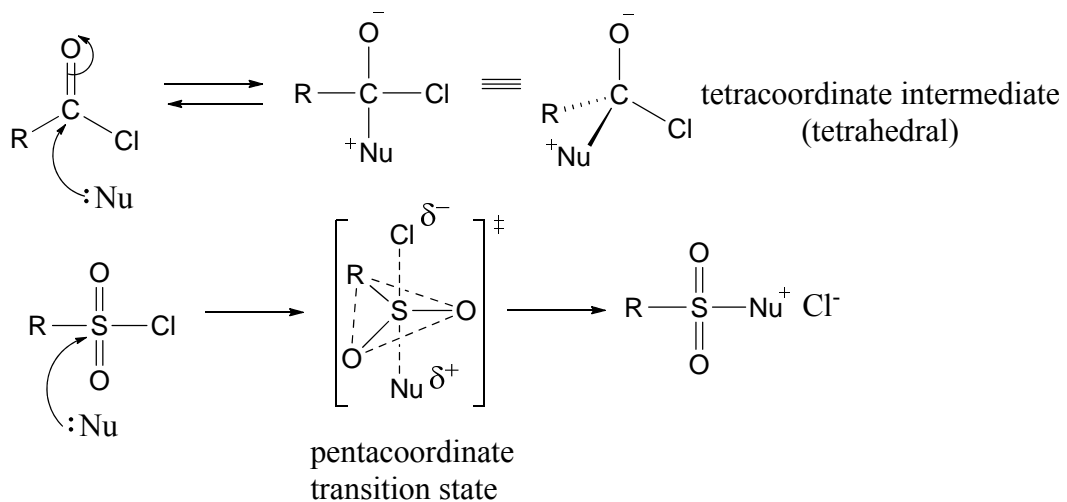

11.23

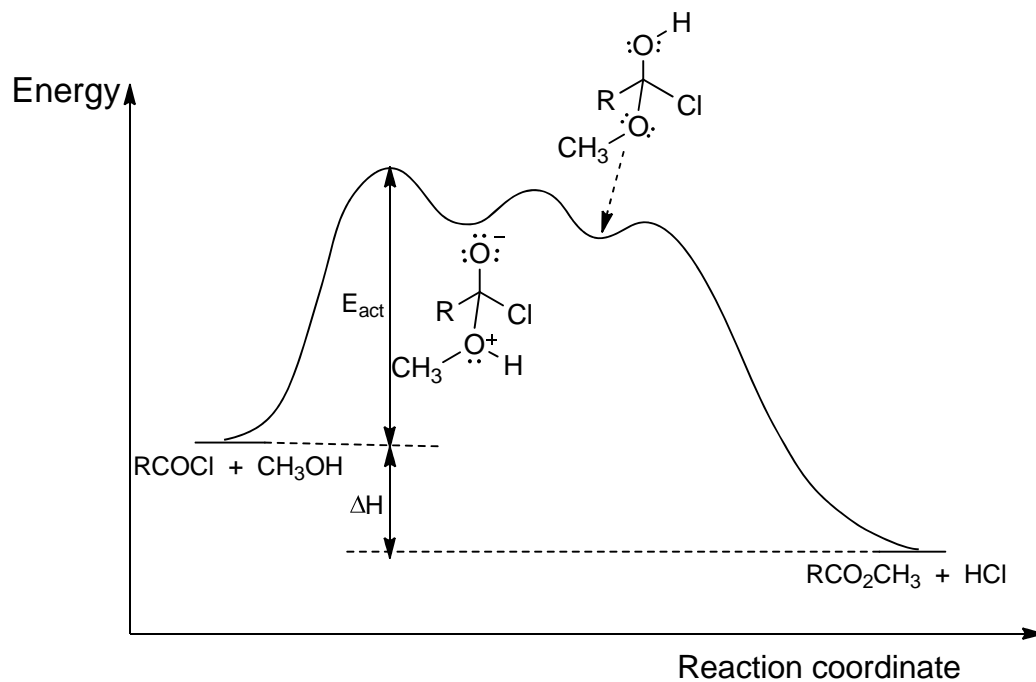
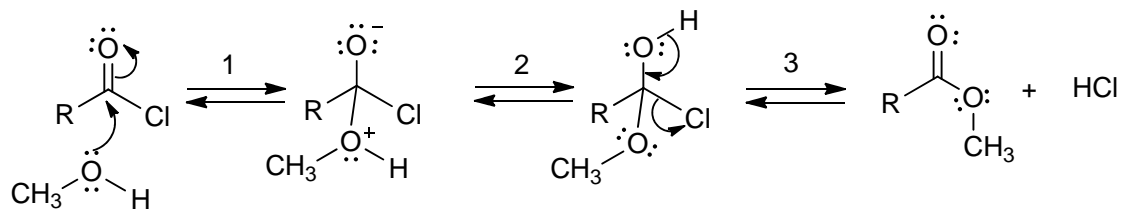

11.24

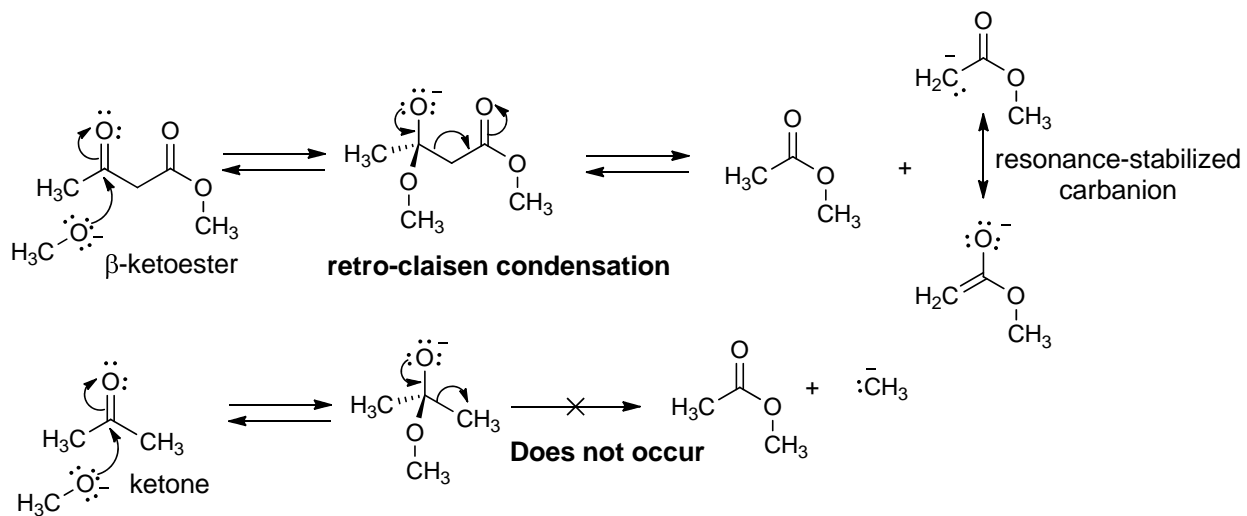

11.25

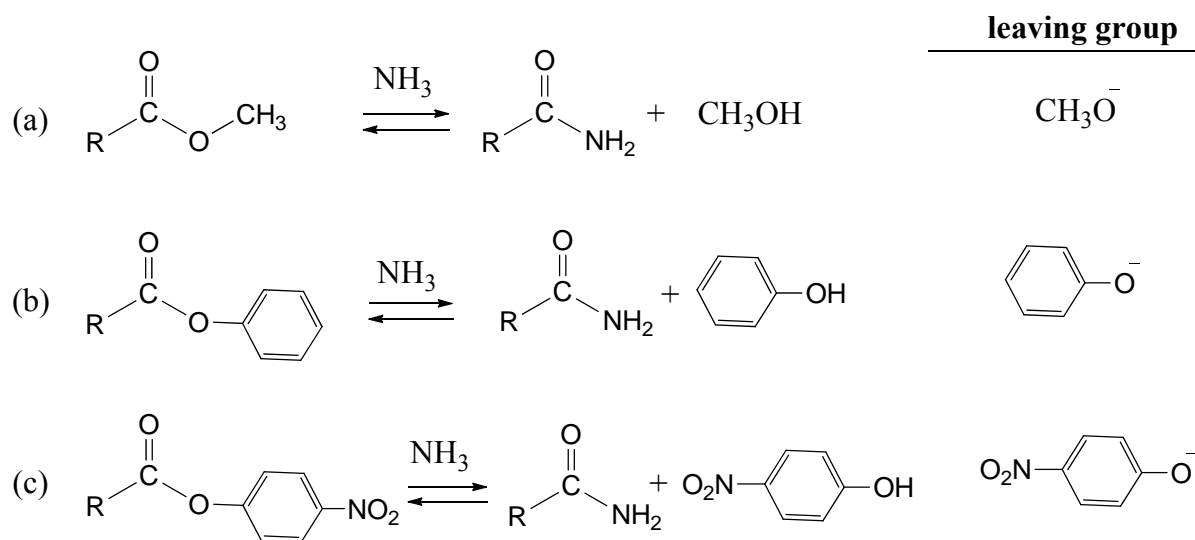

$\text{O}_2\text{N}-\text{C}_6\text{H}_4\text{O}^-$  is a better leaving group than  $\text{CH}_3\text{O}^-$  and  $\text{C}_6\text{H}_5\text{O}^-$  because of greater resonance-stabilized ion. Furthermore, para- $\text{O}_2\text{N}-\text{C}_6\text{H}_5\text{O}^-$  is an electron-withdrawing group. This increases the electrophilic character of the acyl carbon atom of the ester. Therefore, reaction (c) is faster than (a) and (b).

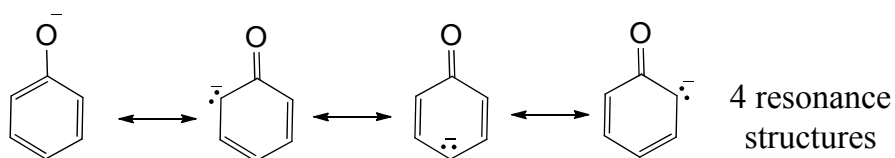
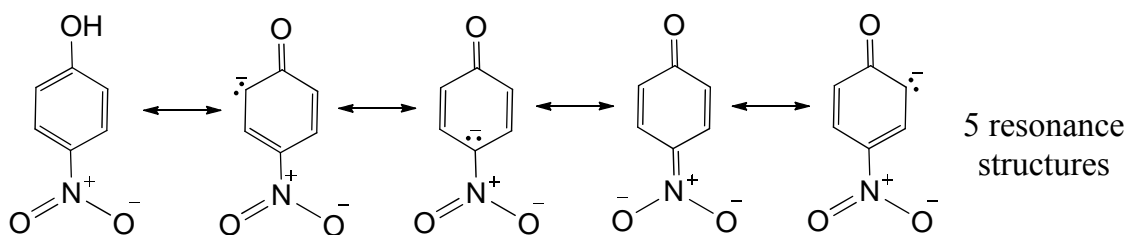

$\text{CH}_3\text{O}^-$  (poor leaving group): no resonance structure

11.26

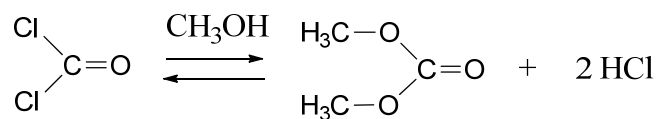

dimethyl carbonate

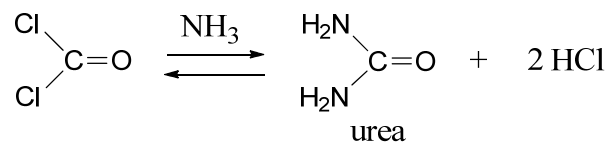

urea

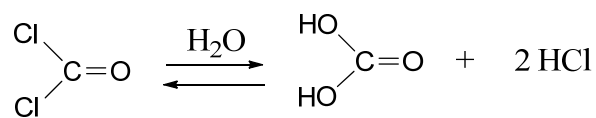

carbonic acid

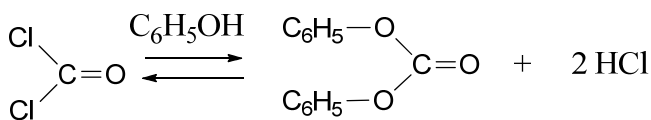

diphenyl carbonate

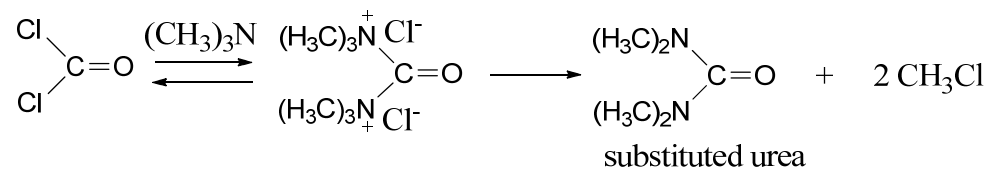

substituted urea

11.27

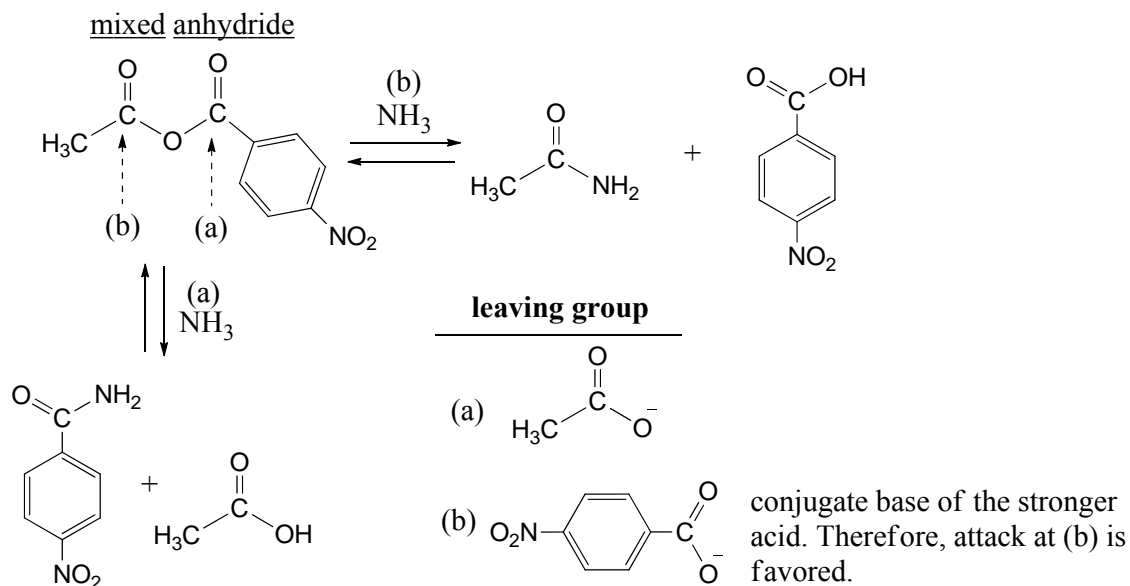

11.28

Because the flexible chain can coil, even sulfonyl groups far apart can reach with ethylene diamine ( $\text{H}_2\text{N}-\text{CH}_2\text{CH}_2-\text{NH}_2$ ).

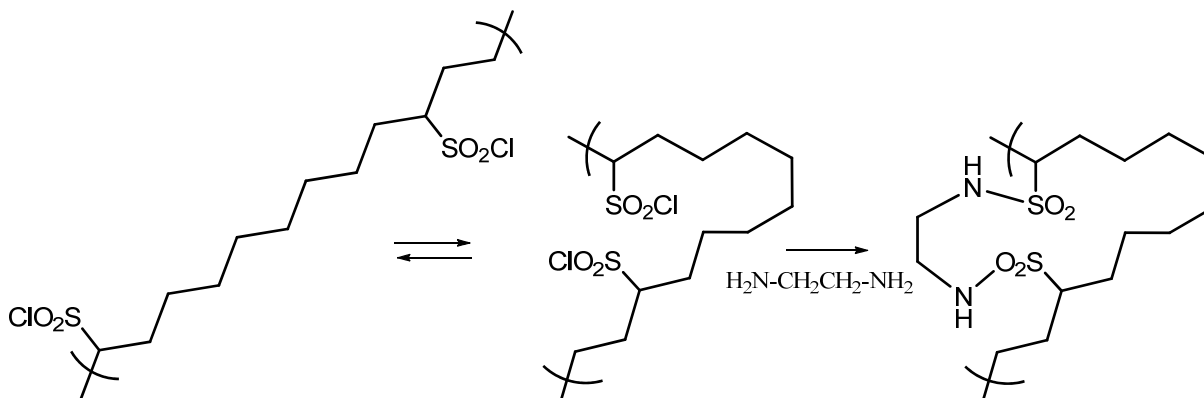

The most effective way to favor intermolecular crosslinking is by increasing the proportion of the polymer to the diamine.

11.29

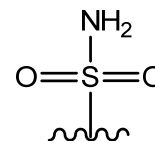
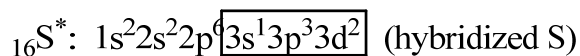
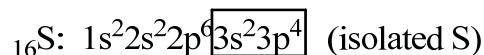

In the hybridized state, one s-orbital (3s) and three p-orbitals (3p) are mixed together to form four  $sp^3$ -hybridized orbitals, which lead to formation of four  $\sigma$ -bonds. The remaining two valence electrons are in two d-orbitals (3d), which overlap with the non hybridized  $p_z$ -orbital ( $2p_z$ ) of the oxygen atoms to give two  $\pi$ -bonds. Alternatively, the structure could be expressed as this resonance structure:

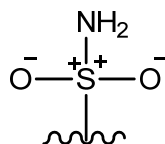

11.30

Resonance is necessary for a full description of both Pronosil and para-aminobenzene sulfonamide.

For example, the following resonance structures contribute to the exact structure of para-aminobenzene sulfonamide:

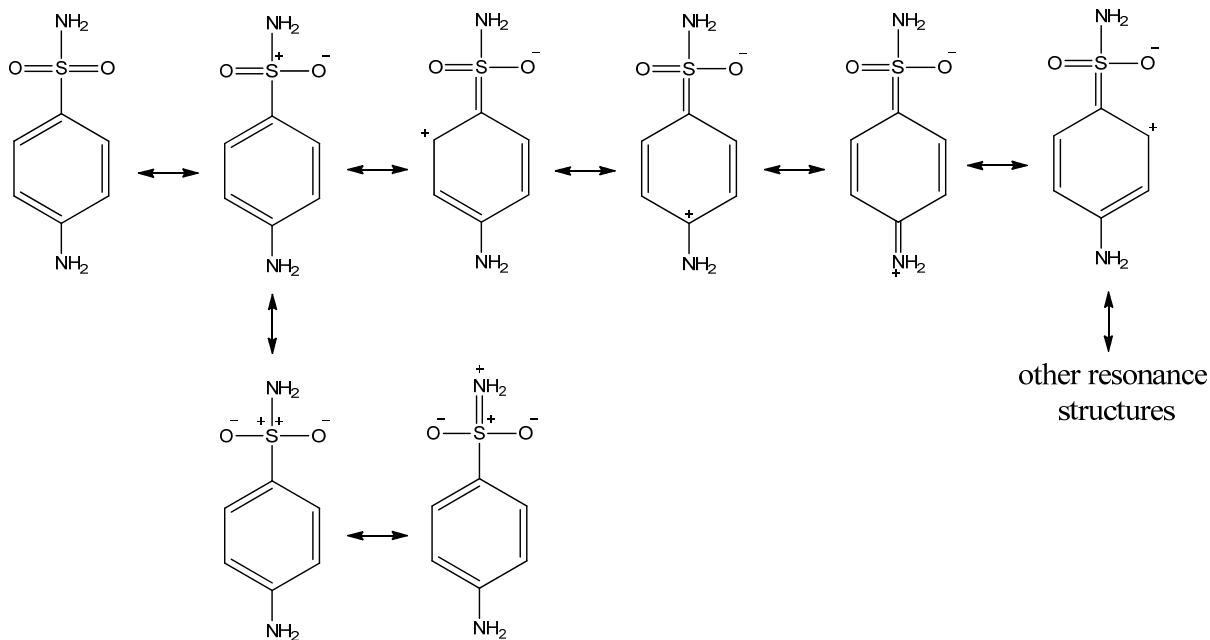

### 11.31

Step 3 (Fig. 11.20) could be enhanced using an excess of initiating peroxide which will result in an increase of the concentration of the radicals produced therefore increasing the rate of reaction 3.

$$\text{Rate (step 3)} = k_3 [\text{radical 1}][\text{radical 2}]$$

### 11.32

The usual experience with the Ziegler-Natta catalyst is that only terminal alkenes can be polymerized so that:

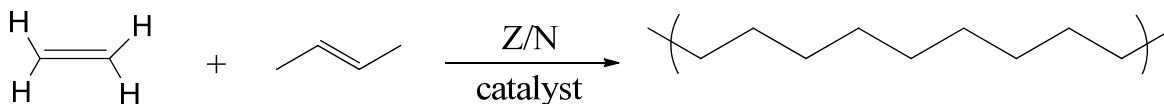
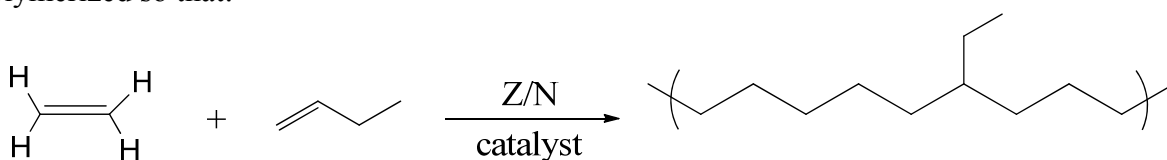

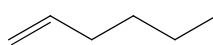
Even  could be used or other terminal alkenes. There must be steric hindrance associated with catalyst activity.



11.33  
Yes.

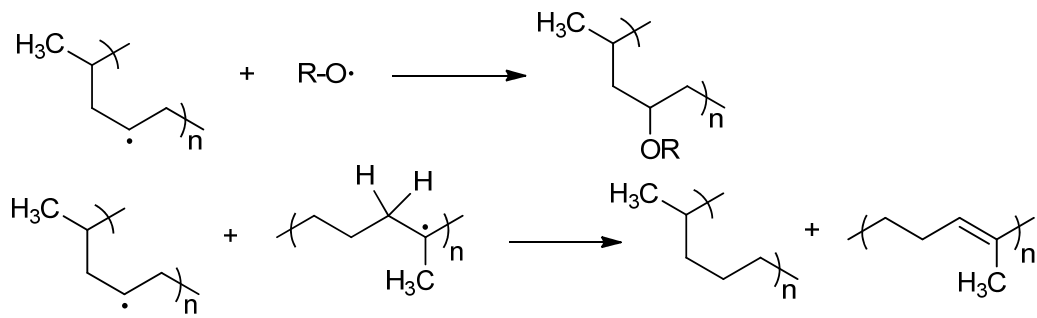

11.34

Kauzmann's paradox has been called a "catastrophe" because it leads to the unphysical situation where the entropy of a disordered liquid would reach zero above 0 °K.

11.35

Both sugars (gulose and idose) are the only ones which have the OH groups in axial orientations, which would cause them to be difficult to crystallize arising from a mixture of ring forms and open forms.

For example:

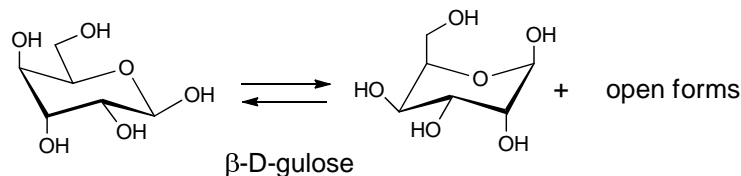

11.36

Lower temperature will be required to slow down the conformational motions to the extent to form the glass, which is rigid.

11.37

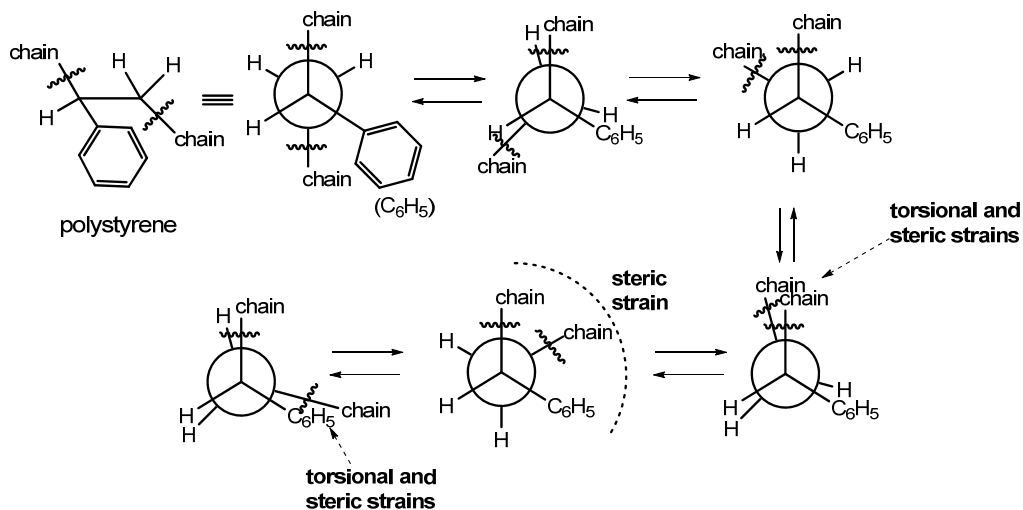

Due to rotation around each carbon-carbon bond along the chain, many conformations are possible but the interconversion between them via eclipsed and gauche is slow due to the presence of steric and torsional strains.

### 11.38

- At 150 °C, both blocks are above their glass transition temperatures allowing chain movement and flow.
- At 30 °C which is lower than the glass transition temperature of polystyrene (100 °C) but higher than the glass transition temperature (-70 °C) of poly (1,3-butadiene), the chains within the poly (1,3-butadiene) region will have the flexibility necessary for elastomeric behavior while the chains within the polystyrene region will form a rigid glass mass.
- At -100 °C, both blocks are below their glass transition temperatures and will therefore form a rigid glass mass.

### 11.39

The soft segment  $-(CH_2)-$  is linear and therefore highly flexible while the presence of stiff aromatic rings in the hard segment causes it to be rigid (limited conformational changes).

### 11.40

Although both polymers work by the same principle in that the polymer consists of blocks that do not mix, Spandex differs from Kraton in that the crosslinking block is not glass-forming but rather finds the necessary temperature –dependent attractive interactions in crystallization and hydrogen bonding.

- At a temperature below the melting temperature ( $T_m$ ) of the crosslinking blocks and above the glass transition temperature ( $T_g$ ) of the flexible blocks, the material acts as *elastomer*.
- At a temperature above  $T_m$  and  $T_g$ , the material flows.
- At a temperature below  $T_m$  and  $T_g$ , the crosslinking blocks form rigid crystals while the flexible blocks turn into a rigid glass mass.

### 11.41

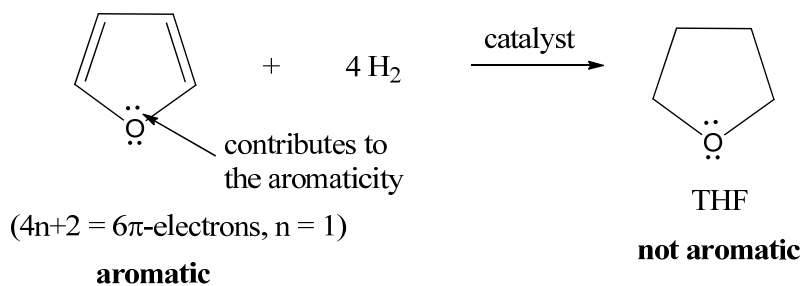

11.42

In Fig. 11.25, the high energy bonds (weak bonds) are:  $\text{C}-\overset{+}{\text{O}}$  bonds. They are created by introducing a positive charge on the oxygen atom. This lowers the electron density on the oxygen atom and therefore weakens the  $\text{C}-\overset{+}{\text{O}}$  bonds.

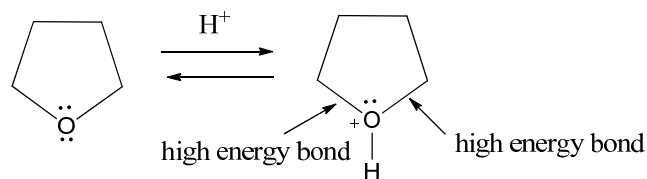

11.43

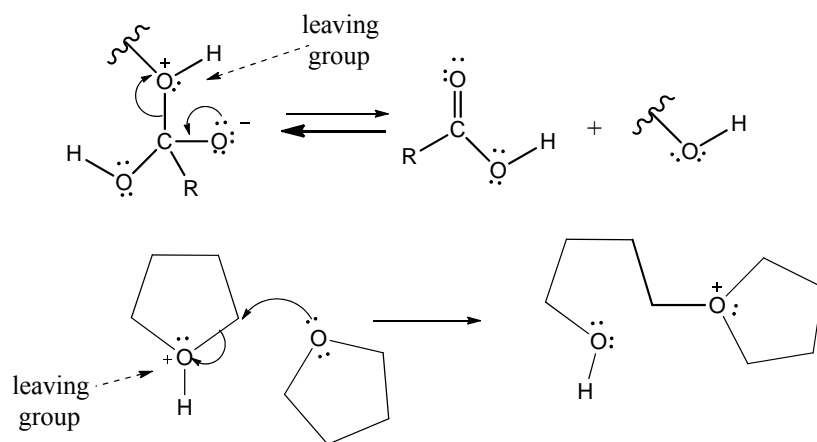

In both cases the leaving groups are similar:  $-\overset{+}{\text{O}}\text{H}$

11.44

Fig. 11.25 describes an addition polymerization. Many units of THF add together without elimination of a small molecule.

11.45

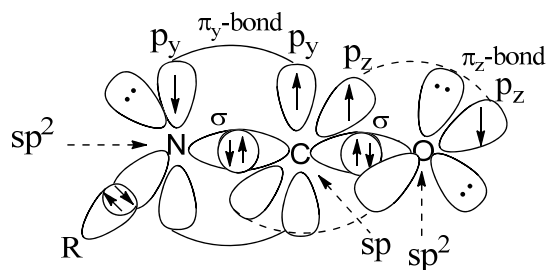

The nitrogen and oxygen atoms are  $\text{sp}^2$ -hybridized while the central carbon atom is  $\text{sp}$ -hybridized, similar to allenes. Therefore, the geometry of the isocyanate functional group is linear

11.46

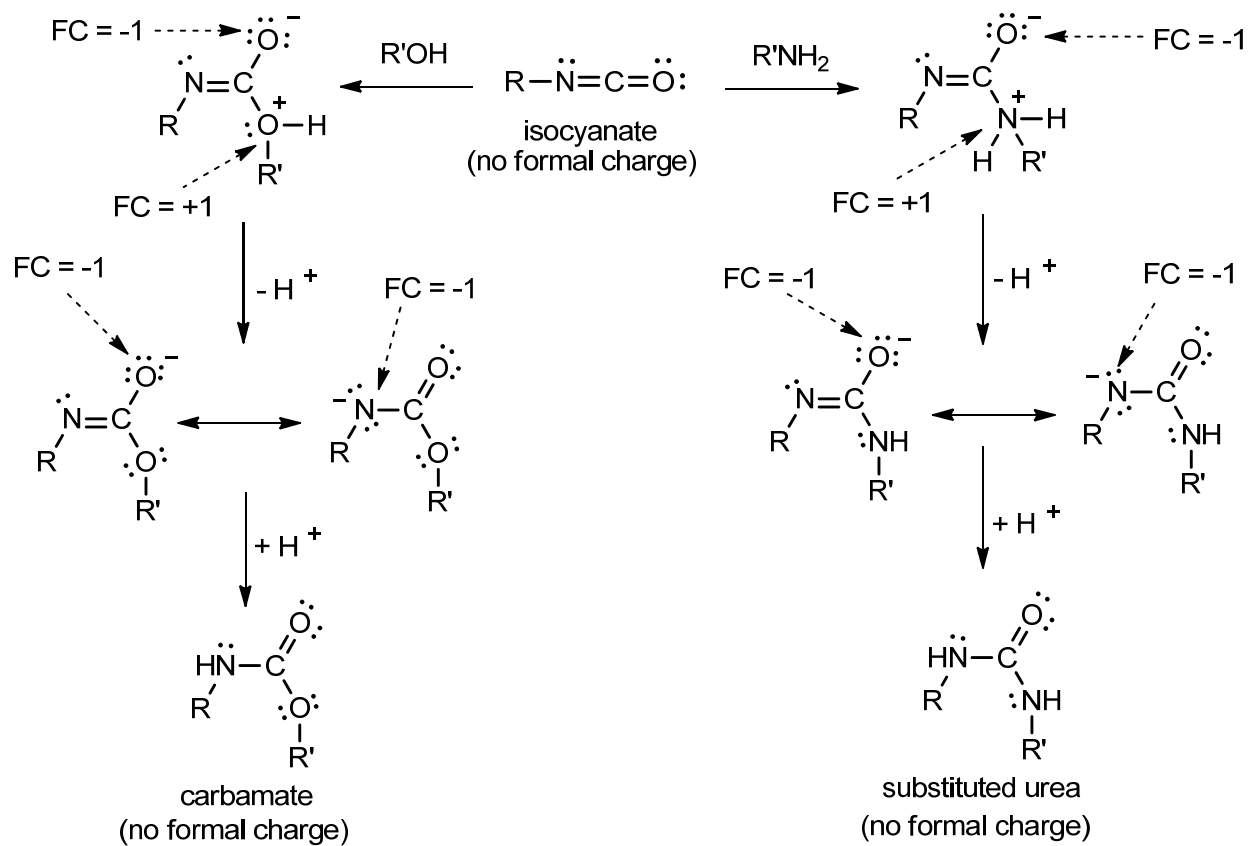

11.47

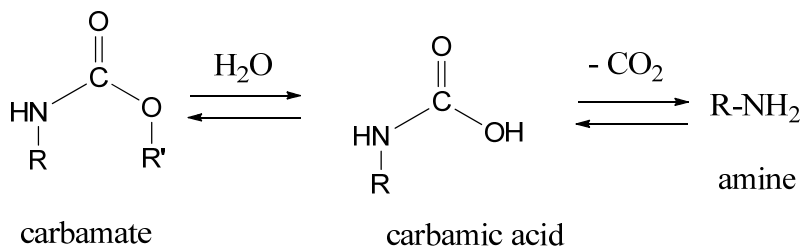

Rapid loss of  $\text{CO}_2$  demonstrates that carbamic acids are unstable.  
 Because of the ease of proton loss. Loss of the  $\text{R}'$  group in the ester is far more difficult.

11.48

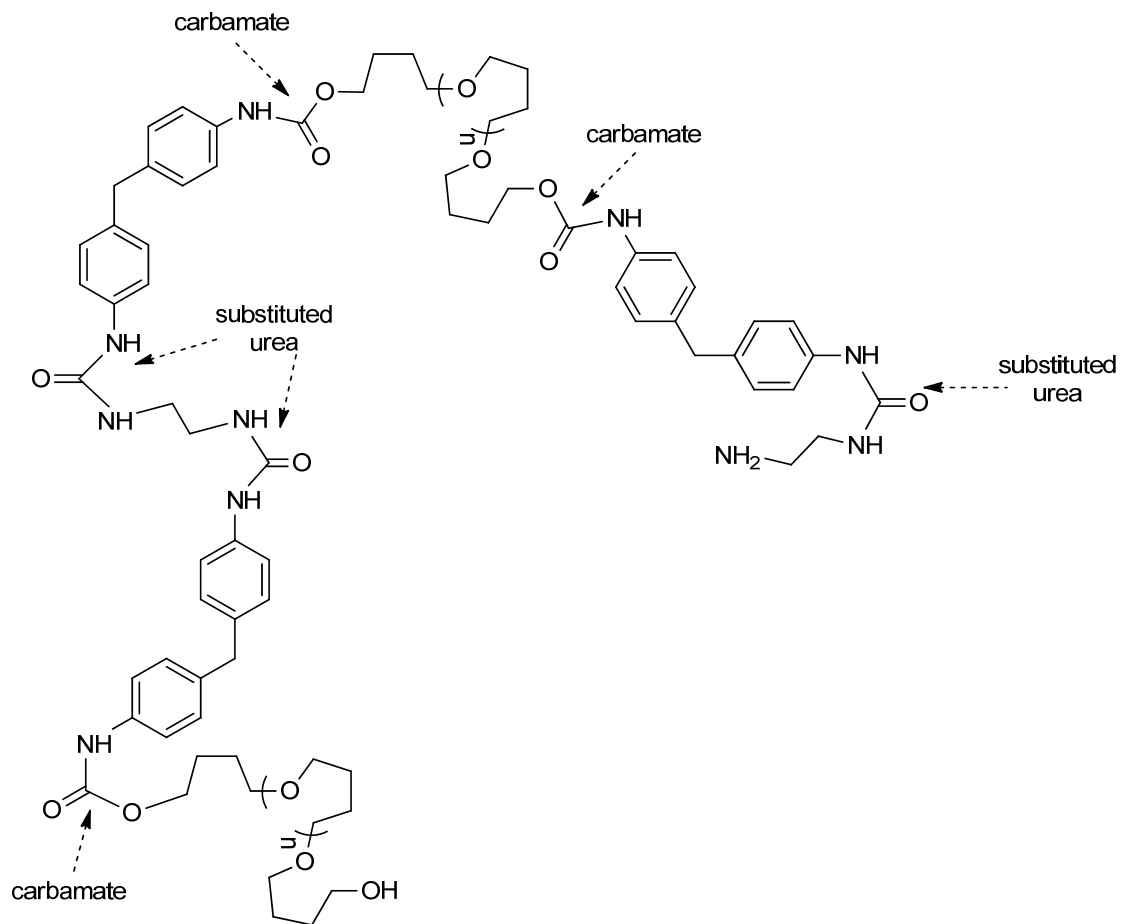

## Chapter 12

### 12.1

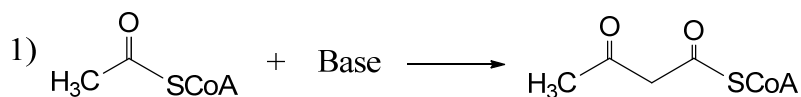

Claisen condensation

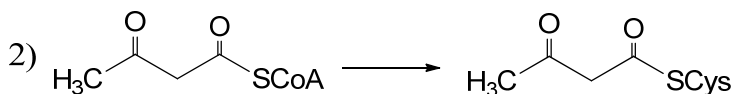

Ester exchange

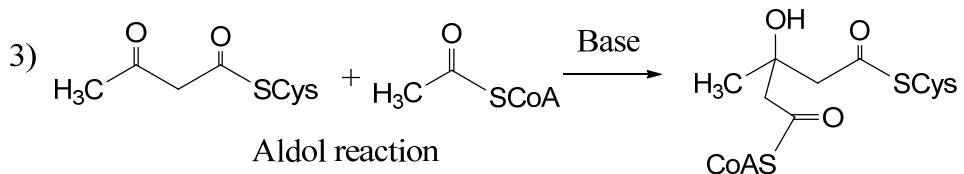

Aldol reaction

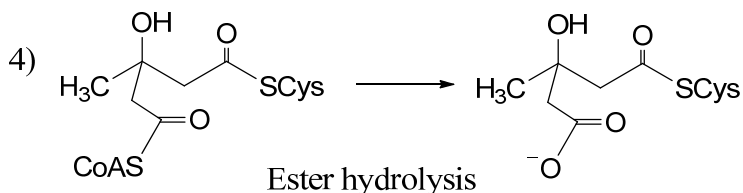

Ester hydrolysis

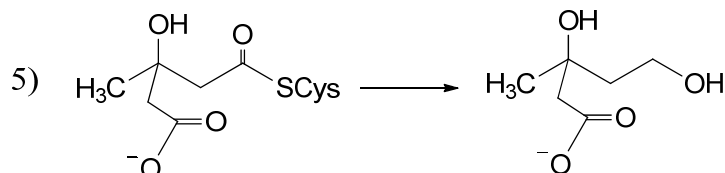

Reduction of an ester to a primary alcohol

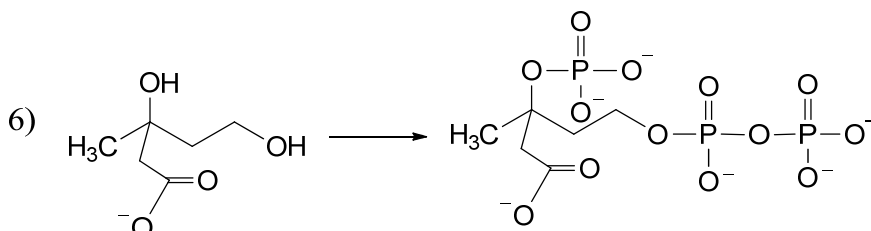

phosphorylation using adenosine triphosphate (ATP)

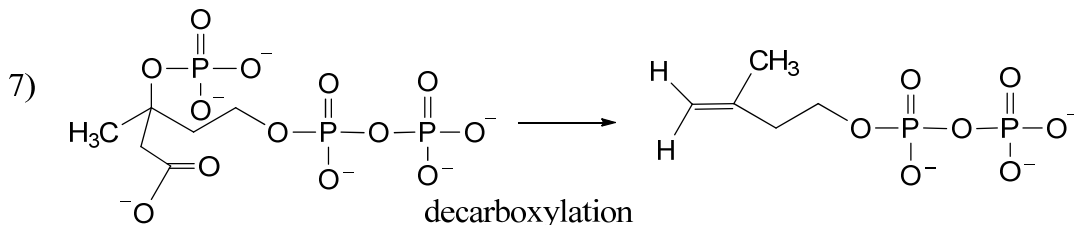

decarboxylation

## 12.2

Let 's do it for three of the structures.

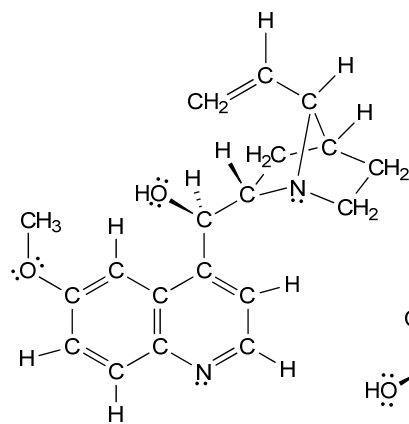

- no formal charge  
-obeys the octet rule

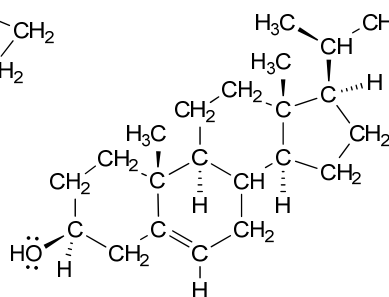

- no formal charge  
-obeys the octet rule

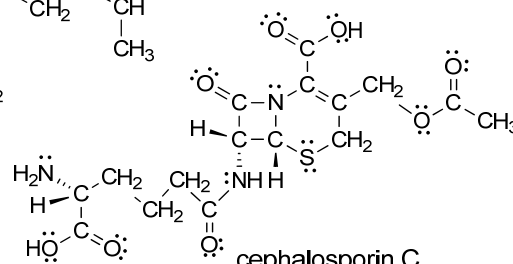

- no formal charge  
-obeys the octet rule

## 12.3

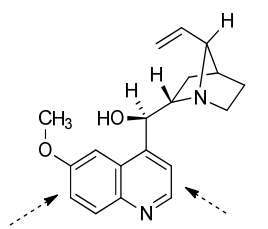

5 conjugated double bonds  
(aromatic system)

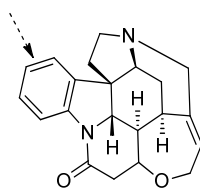

3 conjugated double bonds  
(aromatic system)

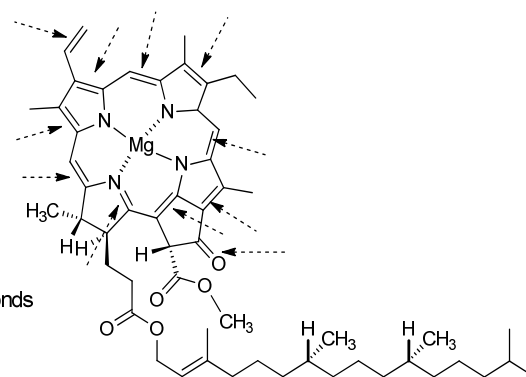

10 conjugated double bonds  
and 1 conjugated carbonyl

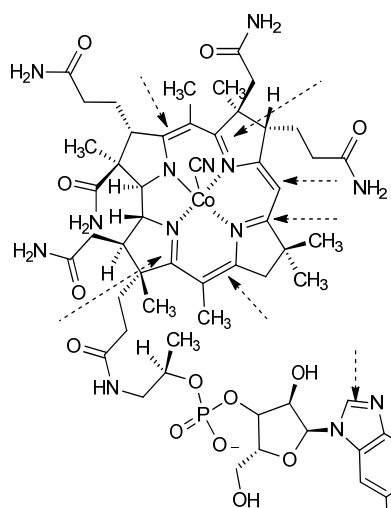

1 conjugated double bond to  
a carbonyl group.

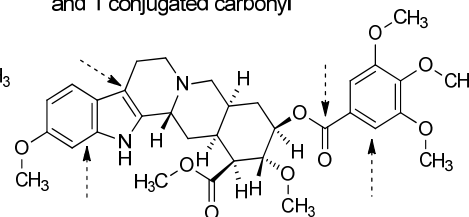

[4+3] conjugated double bonds (two aromatic systems)  
and 1 conjugated carbonyl.

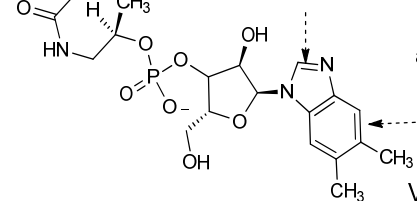

[6+4] conjugated double bonds

## 12.4

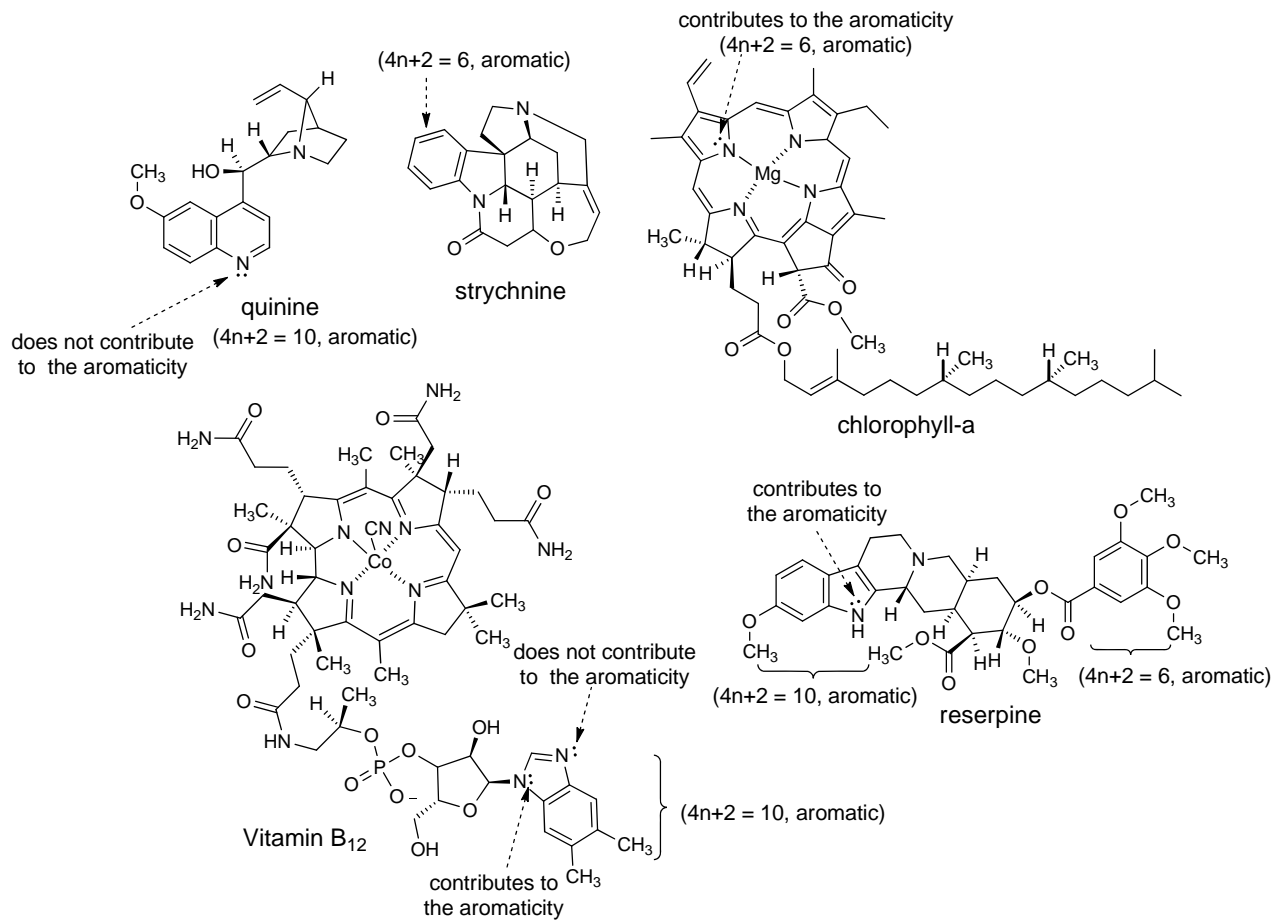

## 12.5

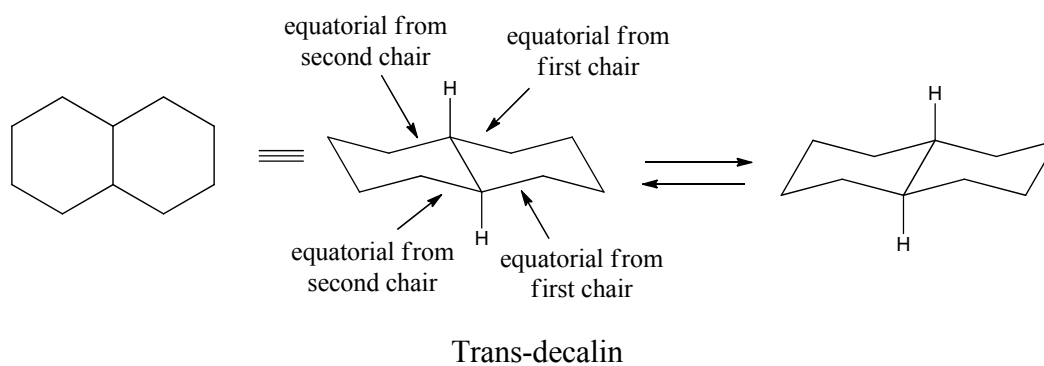

## 12.6

The *s-cis* conformation suffers from the steric hindrance caused by the two CH<sub>3</sub> groups which are close to each other while in the *s-trans* conformation, they are far apart from each other.



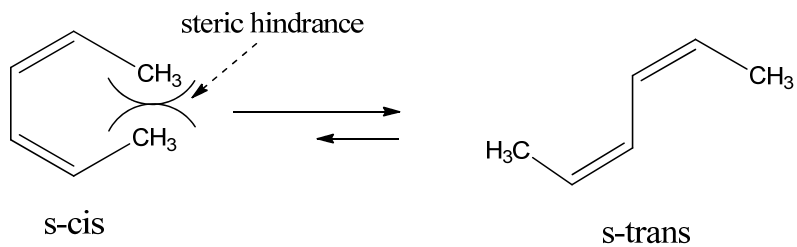

12.7

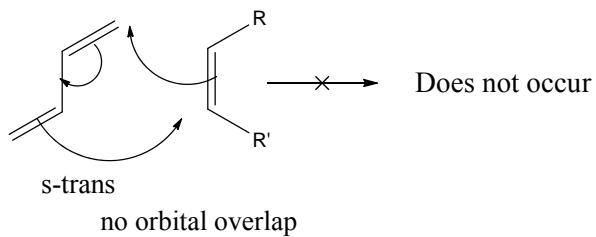
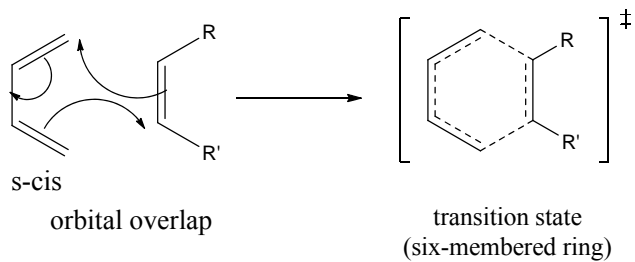

12.8

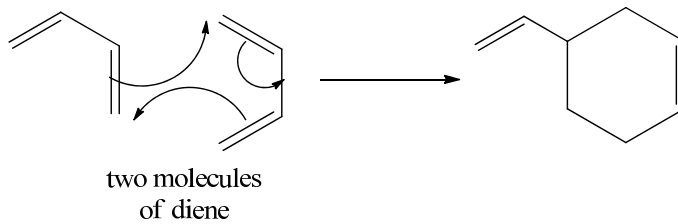
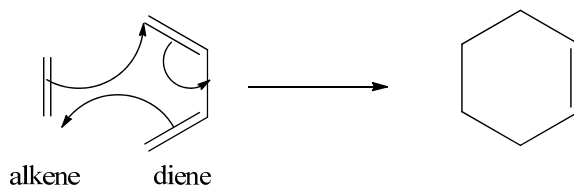

## 12.9

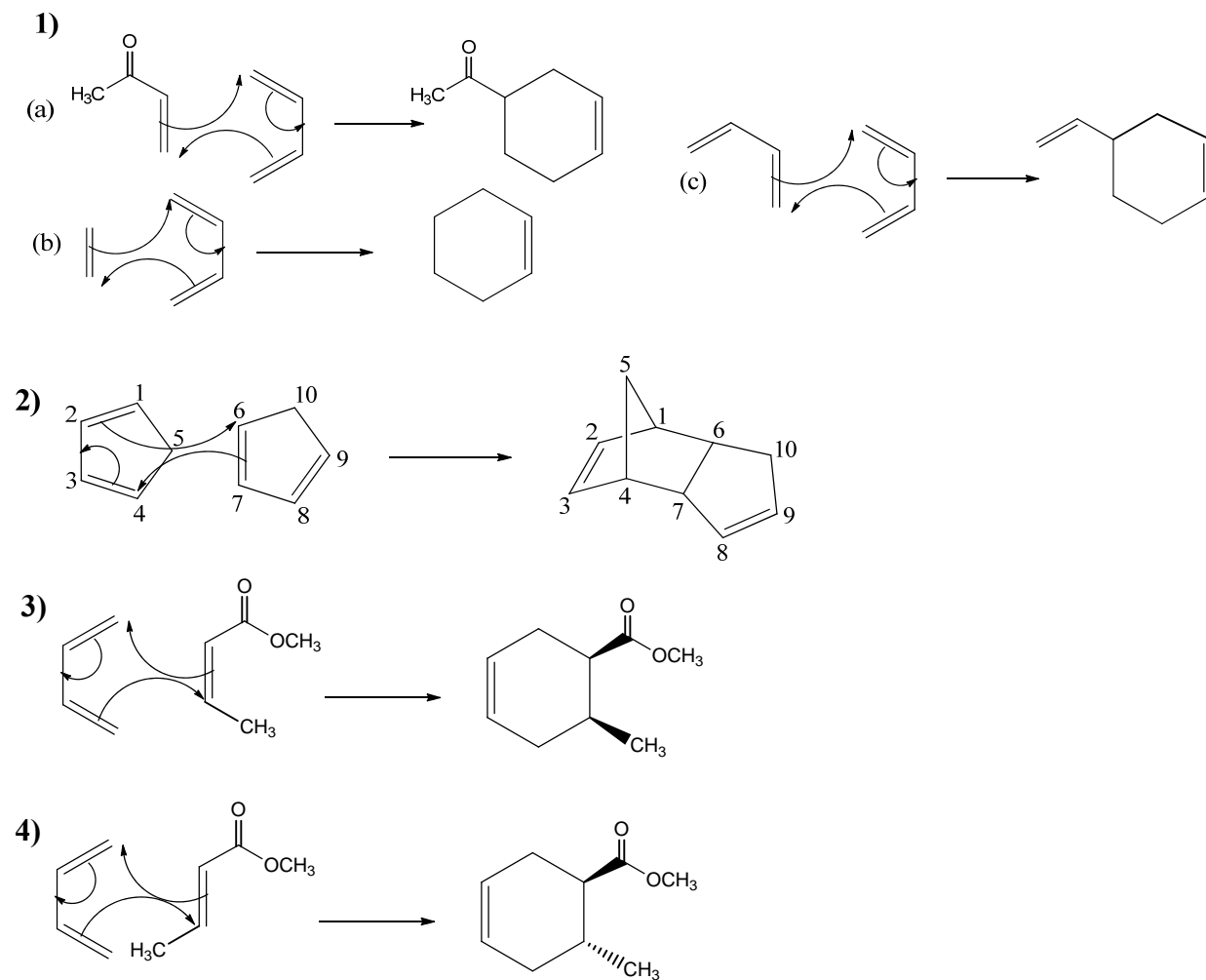

## 12.10

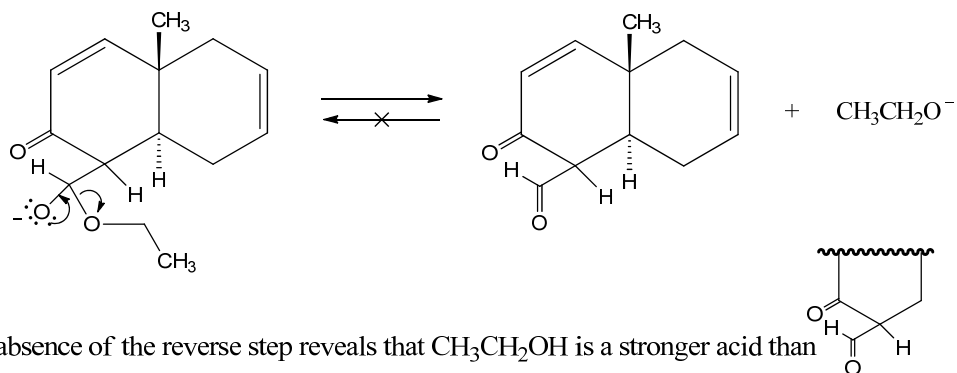

12.11

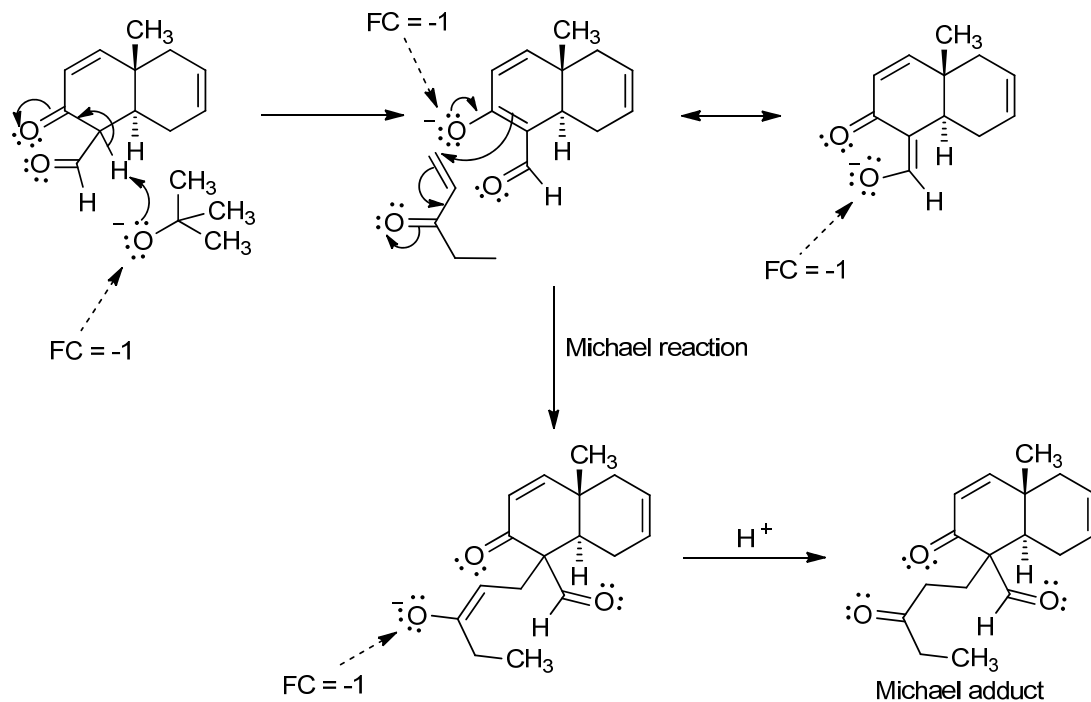

12.12

Although the faces of the carbonyl group are diastereotopic, either face leads to the same result because of the formation of a double bond in the final product.

12.13

The reaction from **2** to **4** is an aldol reaction.

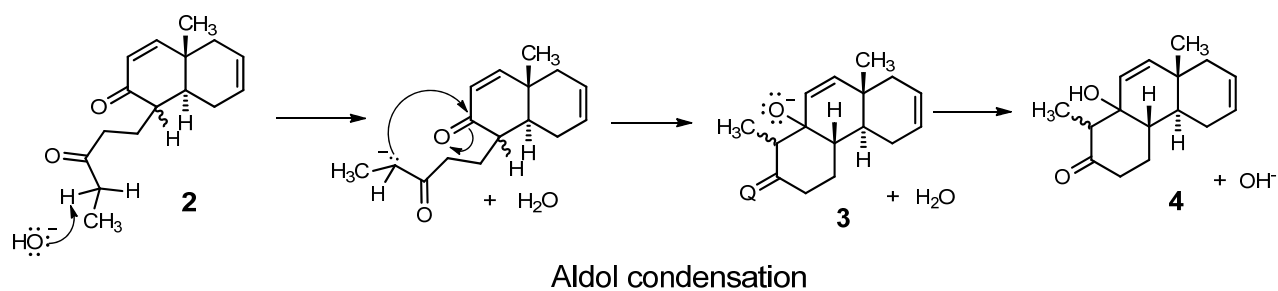

Loss of one molecule of water from **4** has a more powerful driving force than the loss of water from aldol product in Fig. 8.14 because it leads to formation of a diene conjugated to a carbonyl group.

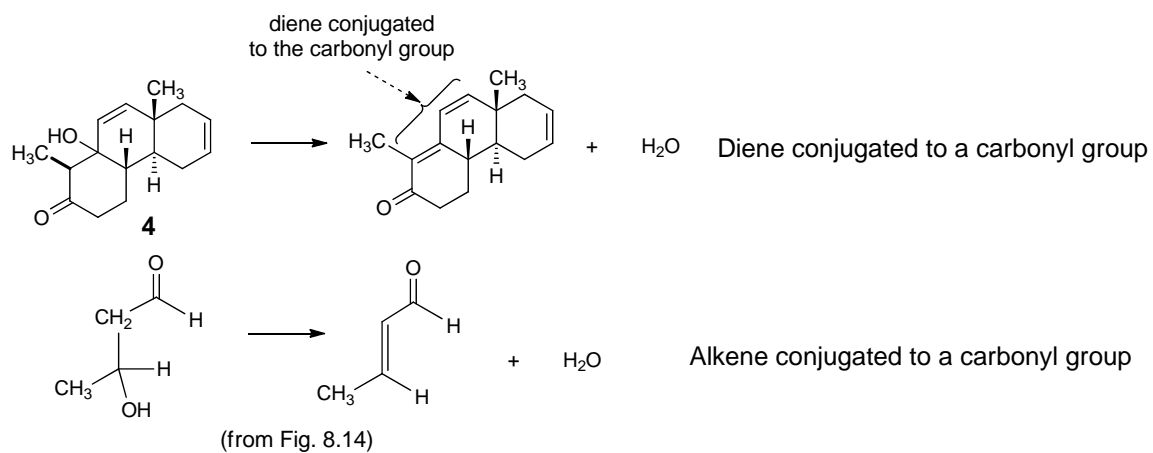

12.14

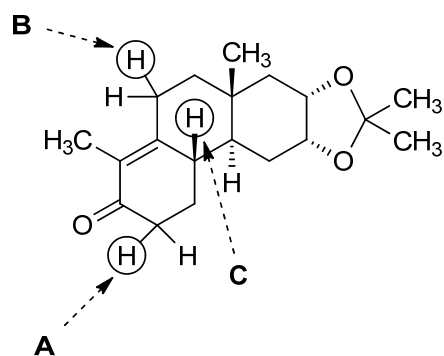

12.15

Proton loss to form **A** (Fig. 12.9) places the negative charge on a carbon atom adjacent to the carbonyl group that is bound to a hydrogen atom while in enolates **B** and **C**, the negative charge is on placed on a carbon atom bearing a methyl group.

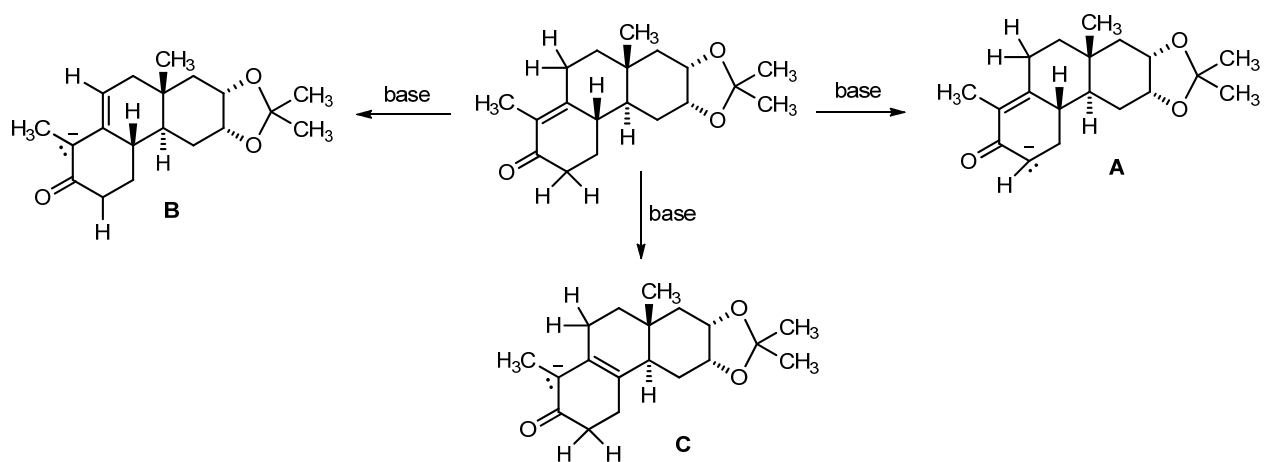

12.16

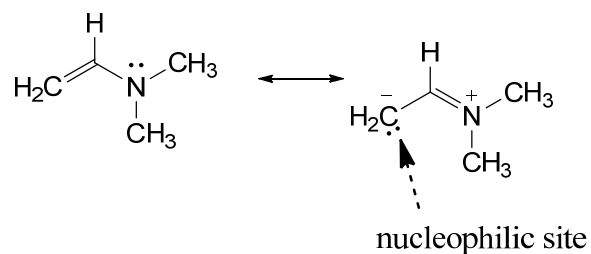

Conjugation of the double bond with the lone pair of the nitrogen atoms makes the CH<sub>2</sub> group, a reasonable nucleophile.

12.17

Both Schiff bases and enamines are synthesized through a series of reversible reactions. Therefore, removal of water prevents the hydrolysis of the products to return to the starting materials.

12.18

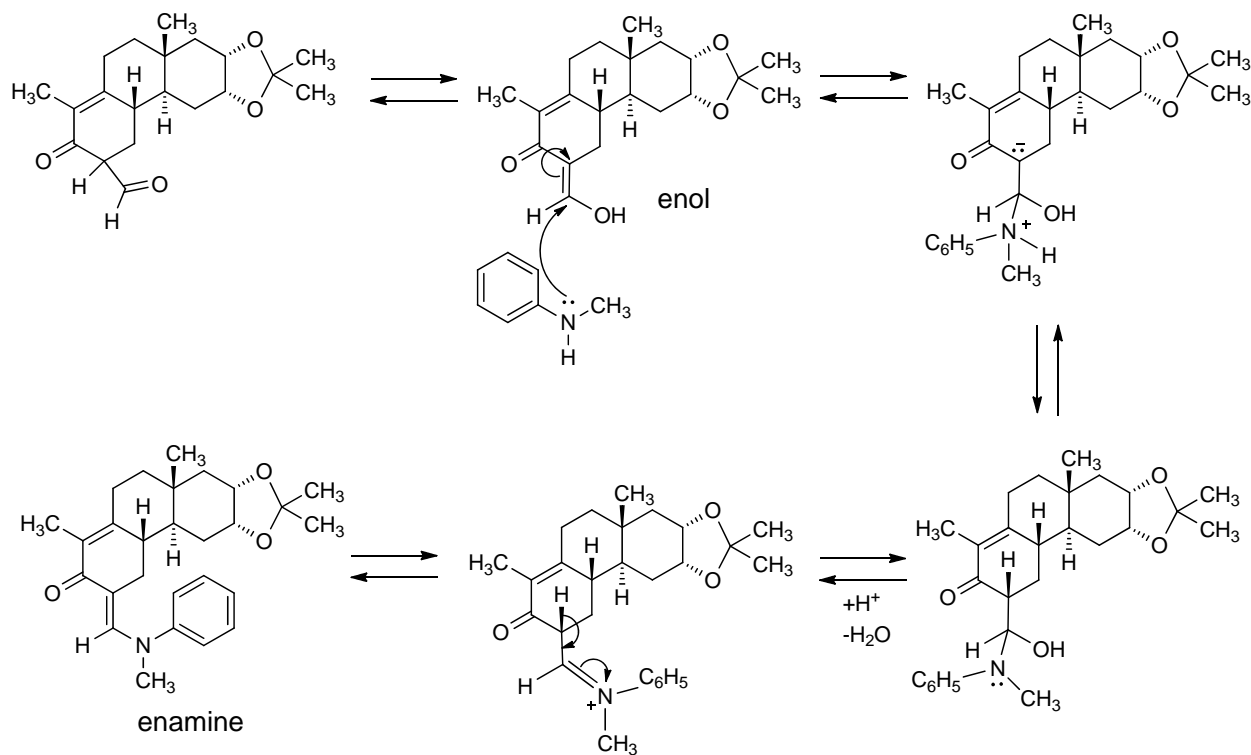

12.19

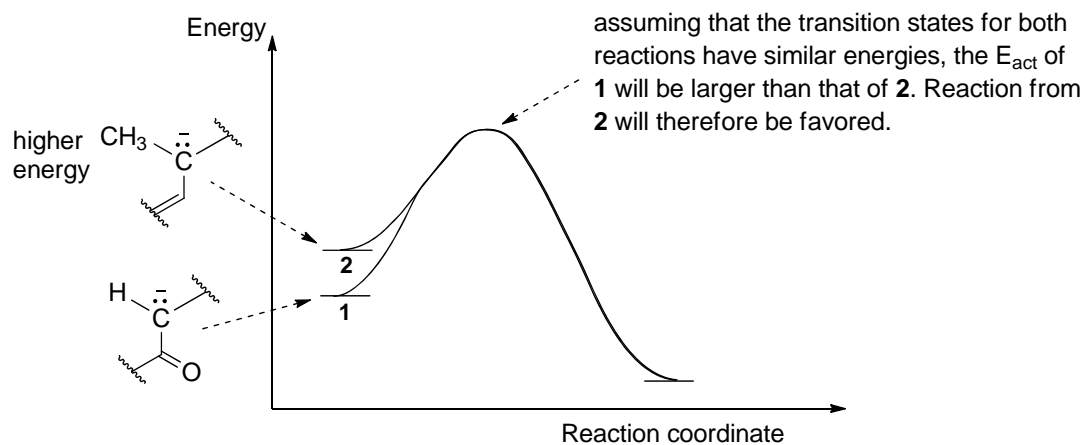

12.20

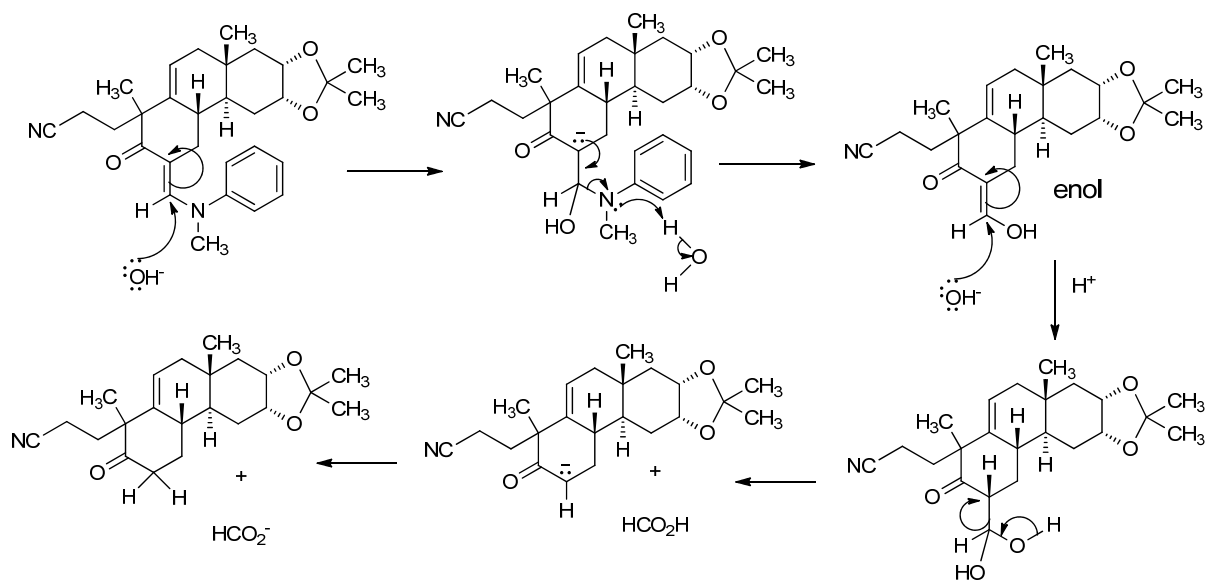

12.21

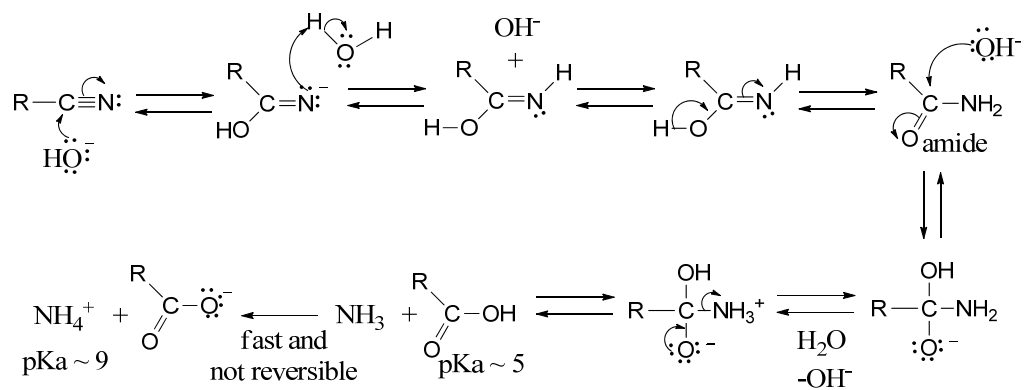

## 12.22

Both steps 2 and 3 are reversible while step 4 is not reversible. Step 2 is an “enol/keto” equilibrium. As the lactone forms and decreases the concentration of the “enol” form (ii), more “keto” form (i) is converted to compensate for the loss, in accordance with the LeChatelier’s principle.

## 12.23

Yes. Woodward could have used the acid chloride to accomplish the same objective. However, the HCl byproduct is a strong acid and could have therefore hydrolyzed the acetal functional group.

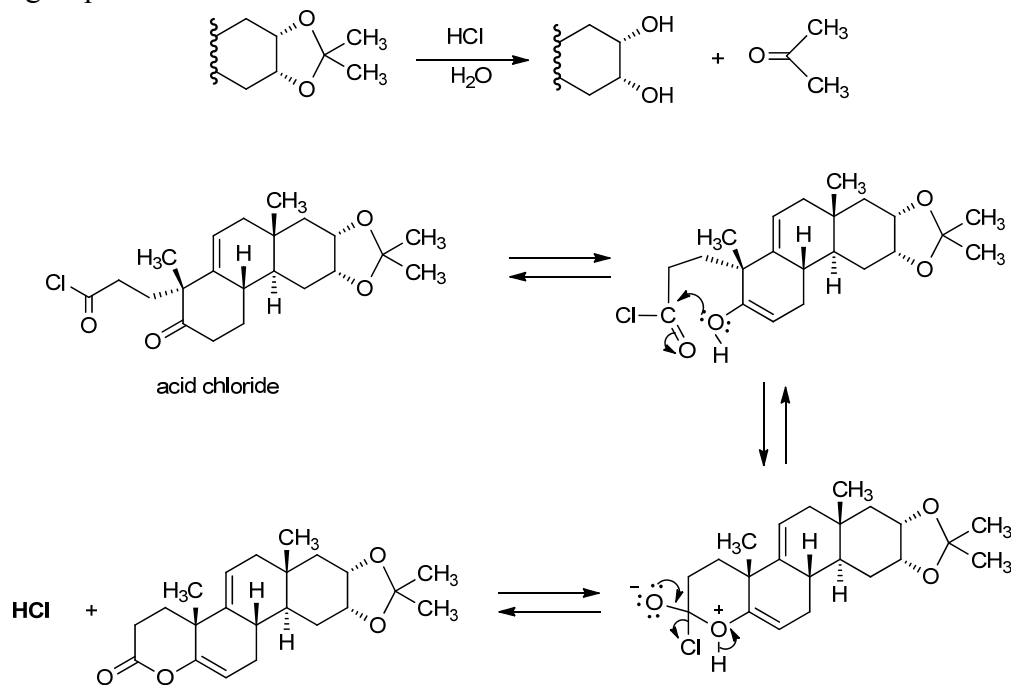

In addition, an acid chloride is more readily hydrolyzed than an acid anhydride.

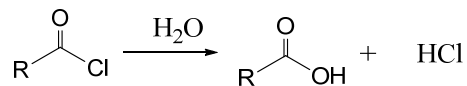

## 12.24

Grignard reagents are very sensitive to the presence of active hydrogen. Therefore, it is strongly recommended to use them under dry conditions and in non protic solvents such as ether, THF. Protic solvents such as H<sub>2</sub>O, CH<sub>3</sub>OH react with Grignard reagents.

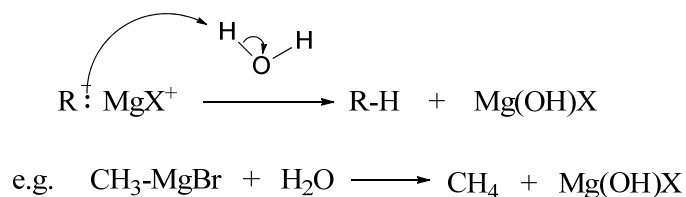

## 12.25

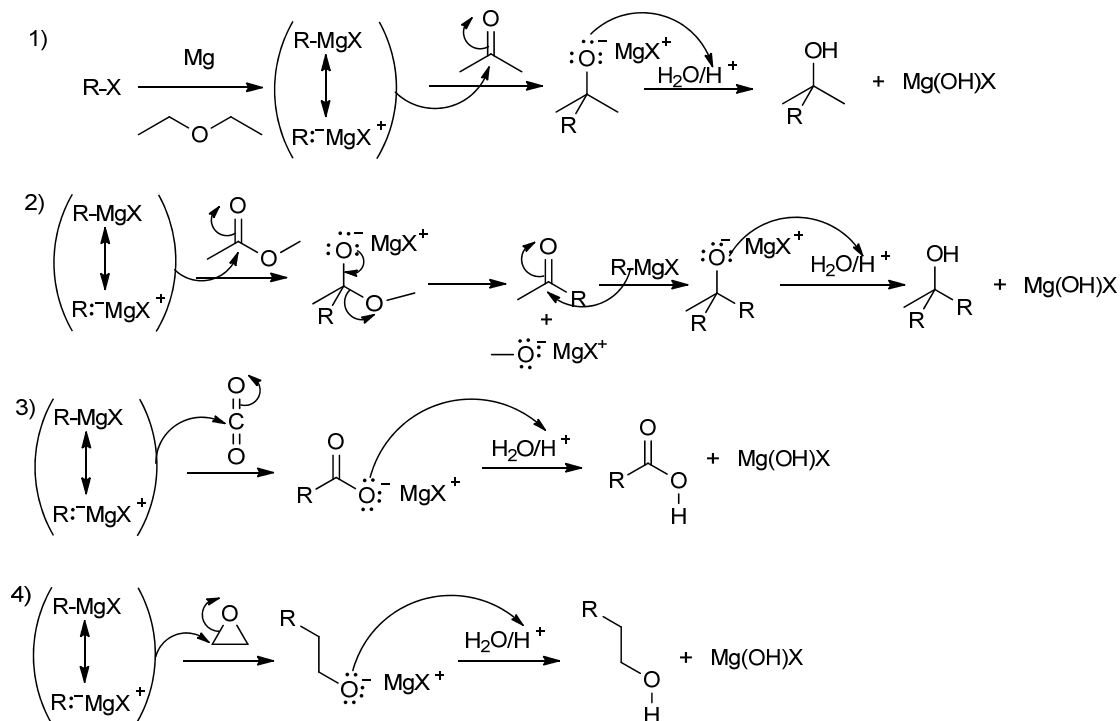

## 12.26

The high energy bond (weak bond) formed in reaction 1 (Fig. 12.16) is:

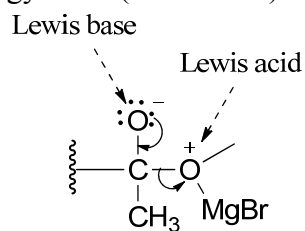

can be viewed as an intramolecular Lewis acid/base reaction.

## 12.27

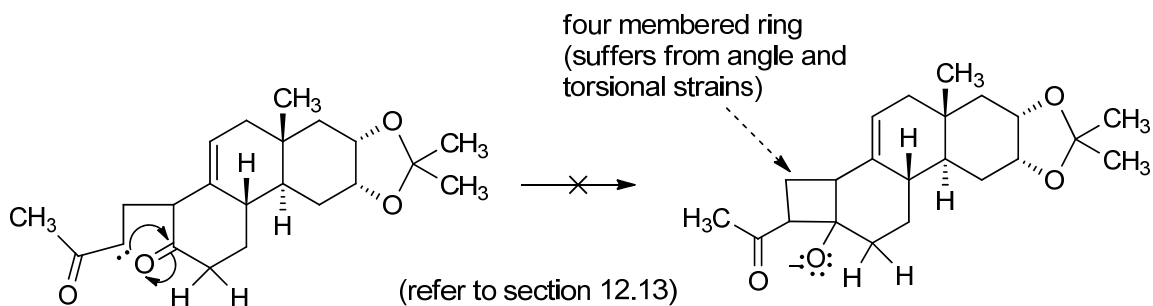



## 12.28

Formation of a double bond conjugated to the carbonyl group is the driving force for loss of water in all Aldol condensations.

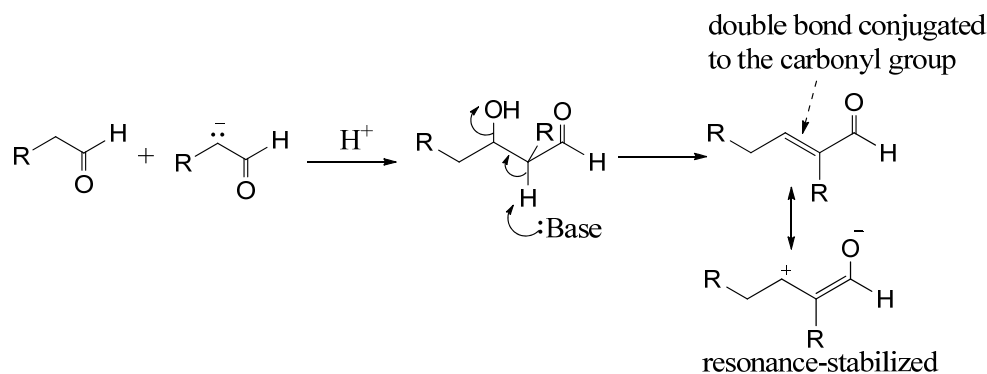

## 12.29

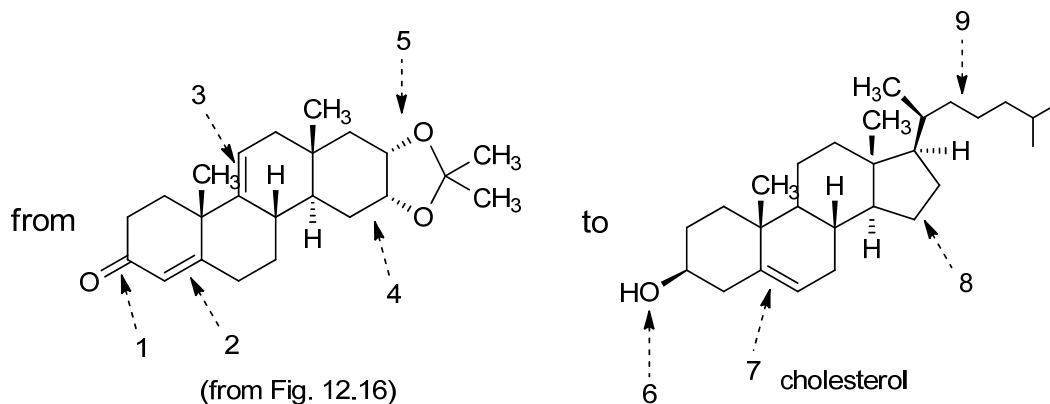

Structural changes that must be made:

- Reduce the keto group (1) to alcohol (6);
- Shift the double bond (2) to form the double bond (7);
- Reduce the double bond (3);
- Convert the six-membered ring (4) to a five-membered ring (8);
- Remove the acetal (5);
- Add a long chain hydrocarbon (9).

## 12.30

The acid catalyst in the mechanism for formation of acetals and ketals converts a poor leaving group ( $OH^-$ ) to a good leaving group ( $H_2O$ ); therefore favoring the nucleophilic attack of the second hydroxyl group.

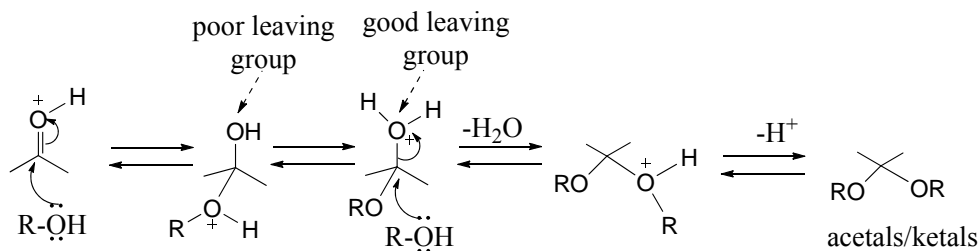

A strong acid would protonate the ROH therefore blocking the reaction.

12.31

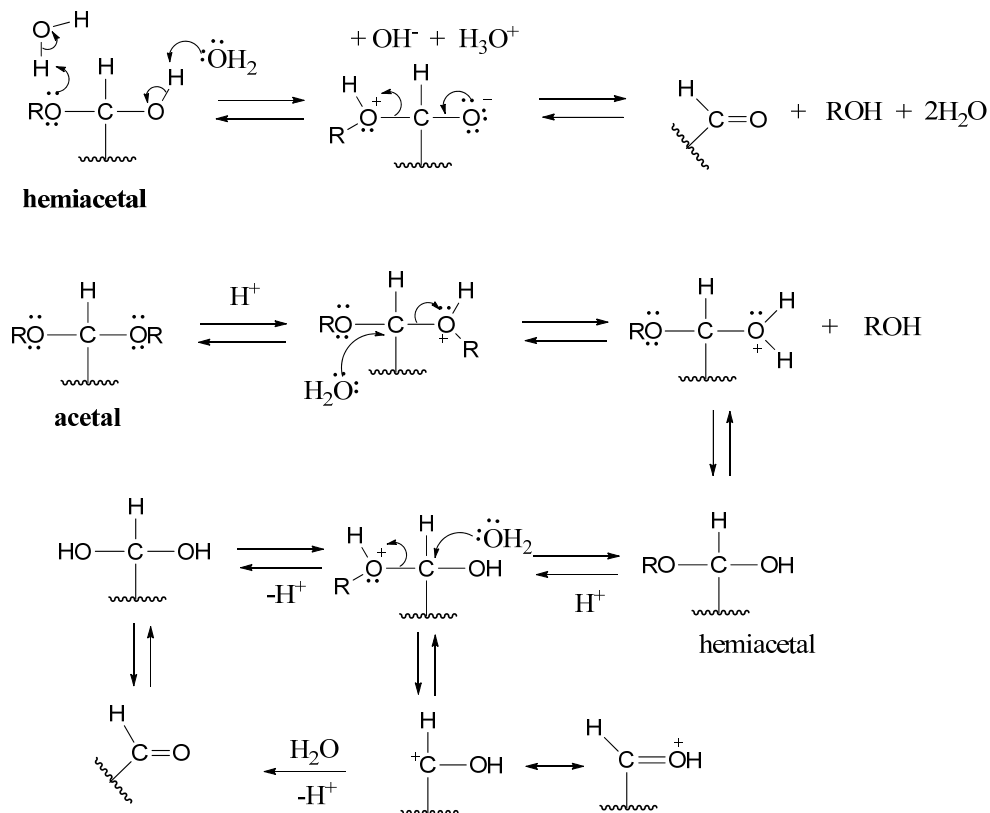

12.32

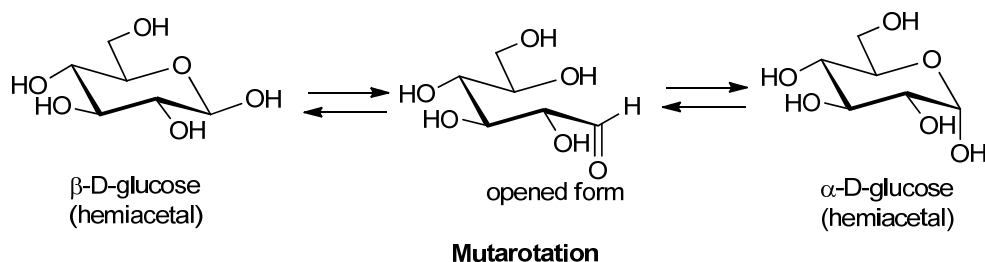

Both anomeric forms ( $\alpha$  and  $\beta$ ) of glucose are hemiacetals formed from the opened form. Mutarotation is the interconversion between two hemiacetals.

12.33

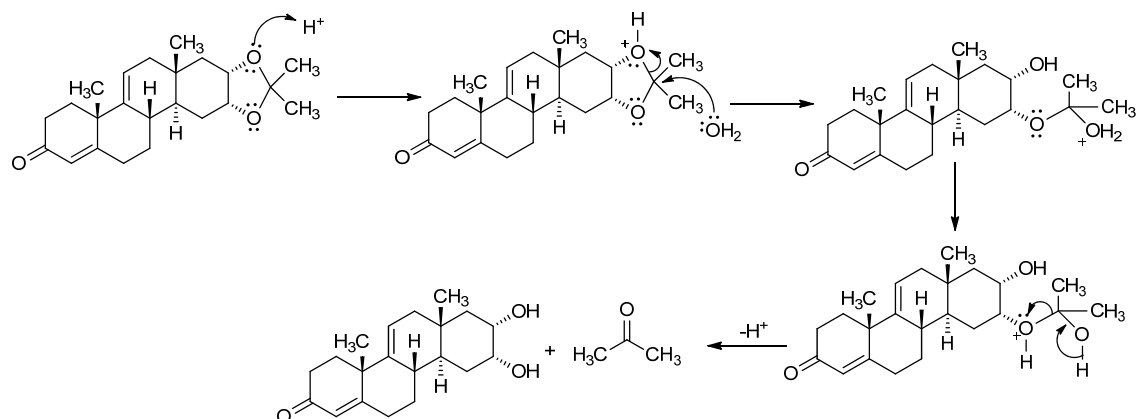

12.34

There are several reasons but the critical one is that Woodward needed the vicinal diol as in Fig. 12.19 in order to produce the dialdehyde from the six-membered ring to synthesize the needed five-membered ring (Fig. 12.19). Several reactions would be interfered with by the unprotected OH groups, which have active hydrogens. Consider the problem of the Grignard reaction (section 12.6).

12.35

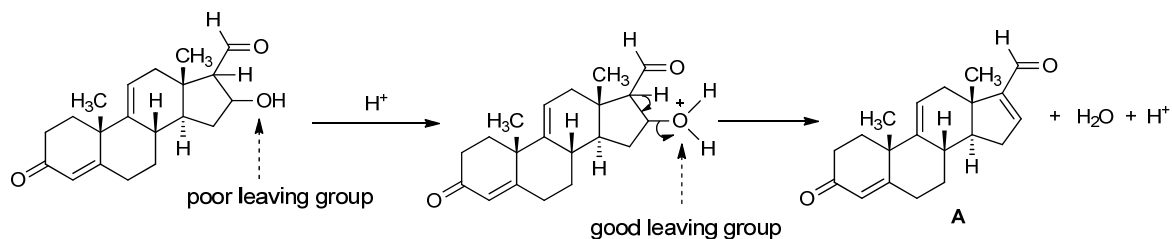

The proton (acid catalyst) converts a poor leaving group ( $\text{OH}^-$ ) to a good leaving group ( $\text{H}_2\text{O}$ ).

12.36

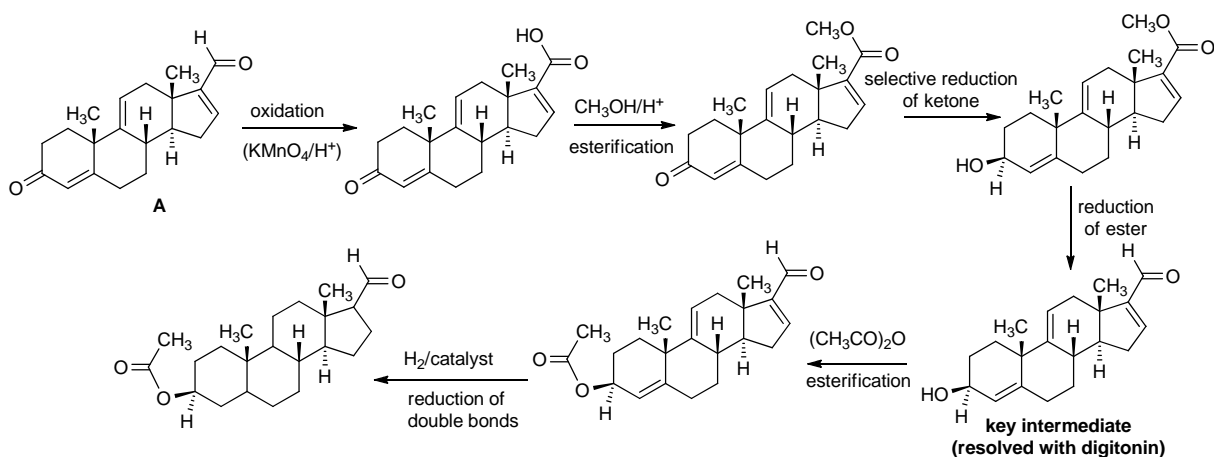

12.37

The resolution using digitonin involved physical interactions such as hydrogen bonding with the racemic molecule. However, chemical reactions could also have been used for the success of the separation. The key necessity is the chirality of the digitonin.

12.38

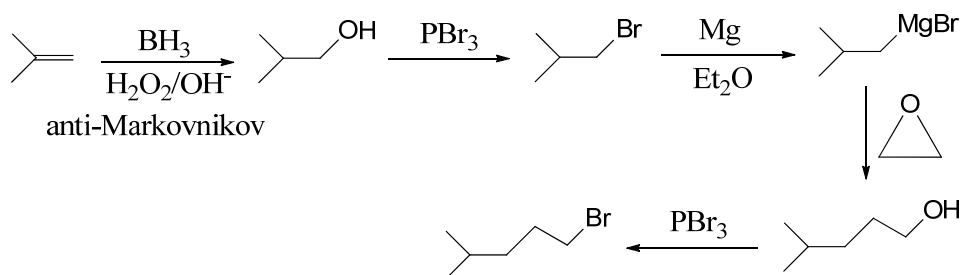

12.39

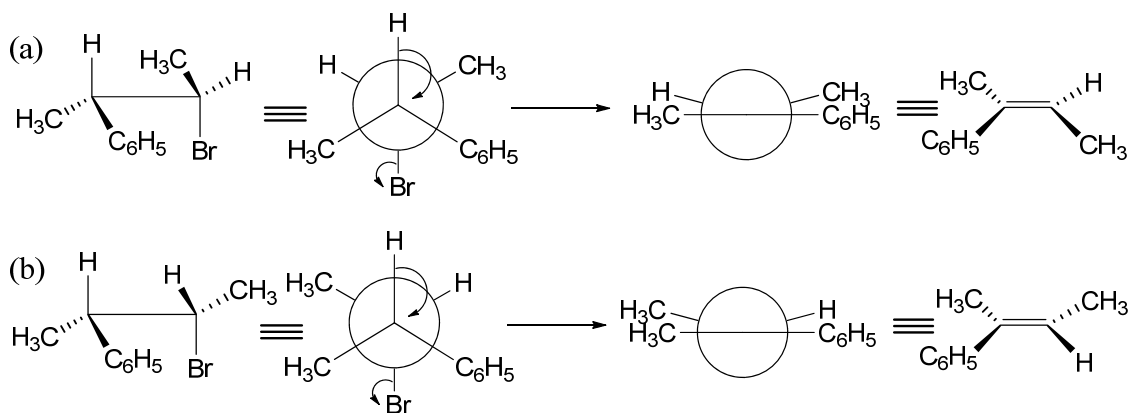

12.40

Convert -OH to -Br or -OTs (tosylate, see section 10.7).

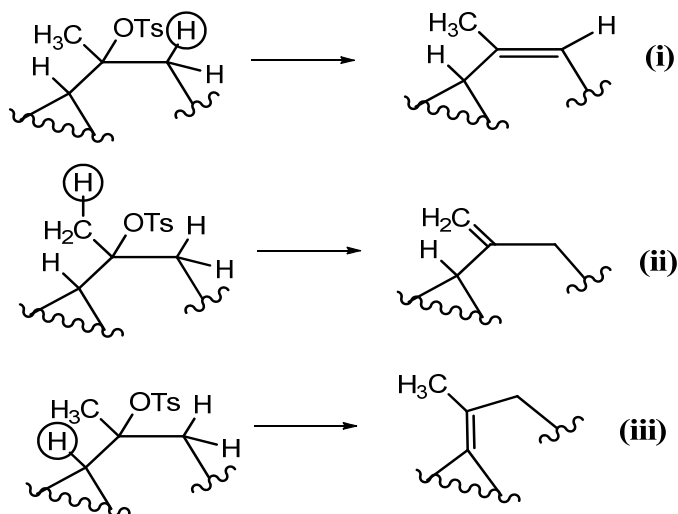

## 12.41

In low dielectric solvents, both  $S_N2$  and E2 are favored.

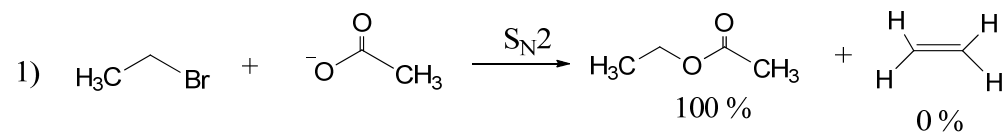

The carbon atom, site of nucleophilic substitution is primary, therefore  $S_N2$  is favored over E2. Note that primary halide substrates ( $R-\text{CH}_2\text{X}$ ) favor  $S_N2$  over E2.

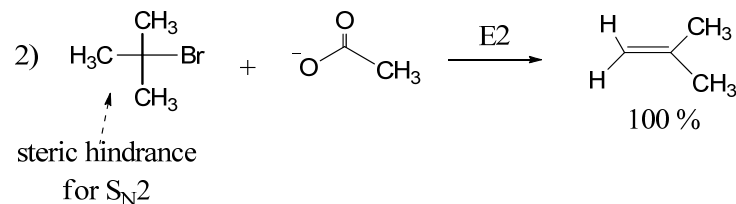

The steric hindrance generated by the three methyl groups hinders the nucleophile from reaching the site for nucleophilic substitution. Therefore, E2 is favored.

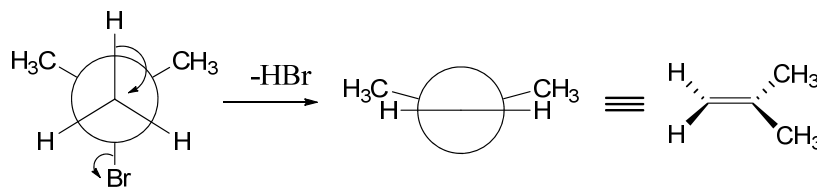

## 12.42

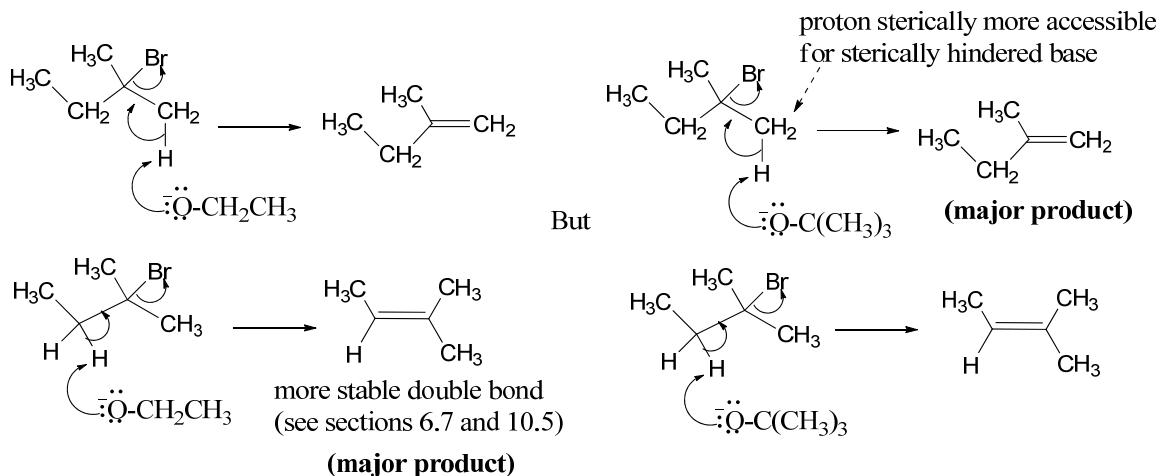

## 12.43

The leaving group,  $\text{Br}^-$ , in reactions 1, 2, 3 is a good leaving group while  $\text{OH}^-$  in reactions 4, 5, 6 is a poor leaving group. Therefore, the fundamental role of  $\text{H}_2\text{SO}_4$  is to convert  $\text{OH}^-$  to a good leaving group,  $\text{H}_2\text{O}$ .

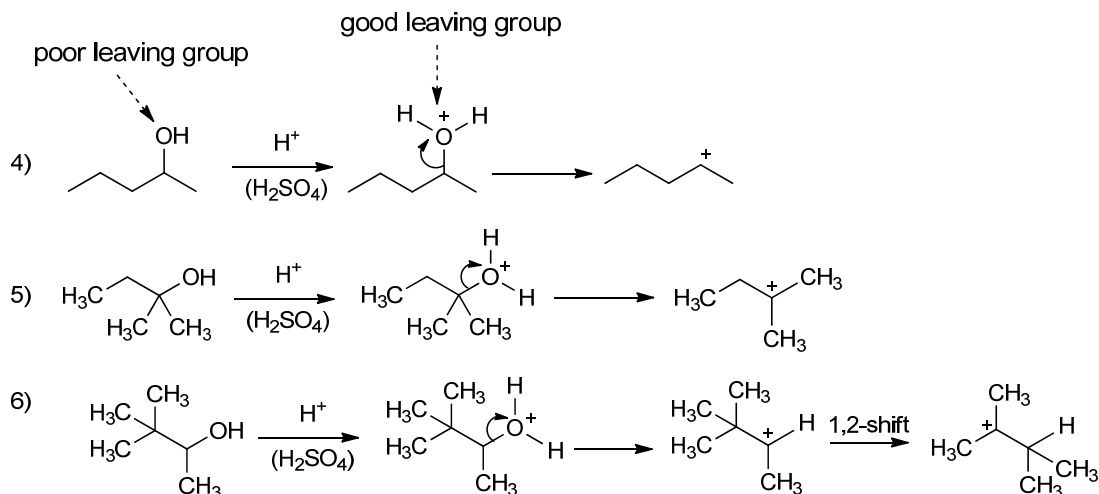

The intermediate carbocation goes on via this  $S_N1$  mechanism to produce the more stable double bond as seen, the more substituted double bond.

#### 12.44

E1cB mechanism which looks similar to E2, usually occurs in the last step of Aldol condensation, leading to a double bond formation. Here, the carbonyl group increases the ease of abstraction of an adjacent proton, which is followed by loss of  $\text{OH}^-$  (H-bonded to water) to form the double bond.

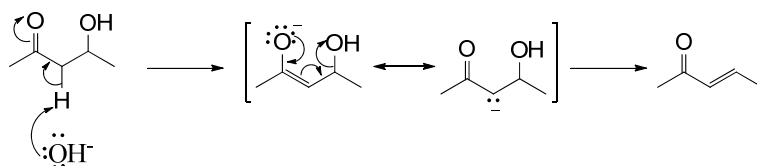

Some examples in Woodward's synthesis are:

(a) Last step (Fig. 12.8)

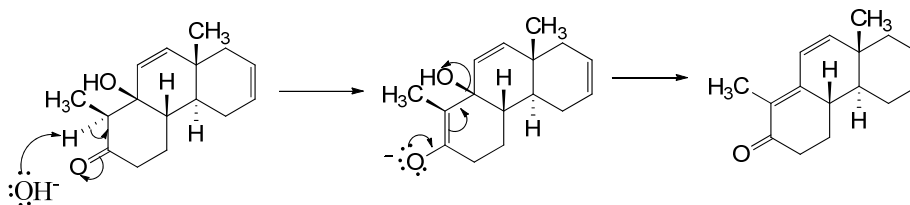

(b) Step 7 (Fig. 12.16)

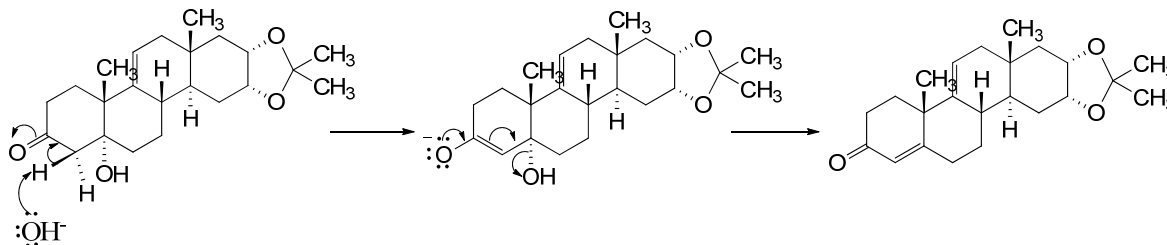

12.45

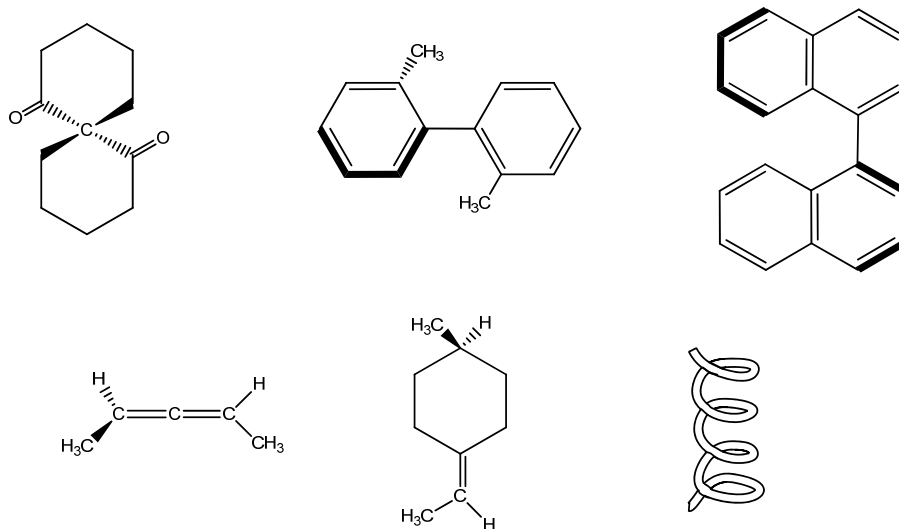

All axially dissymmetric

12.46

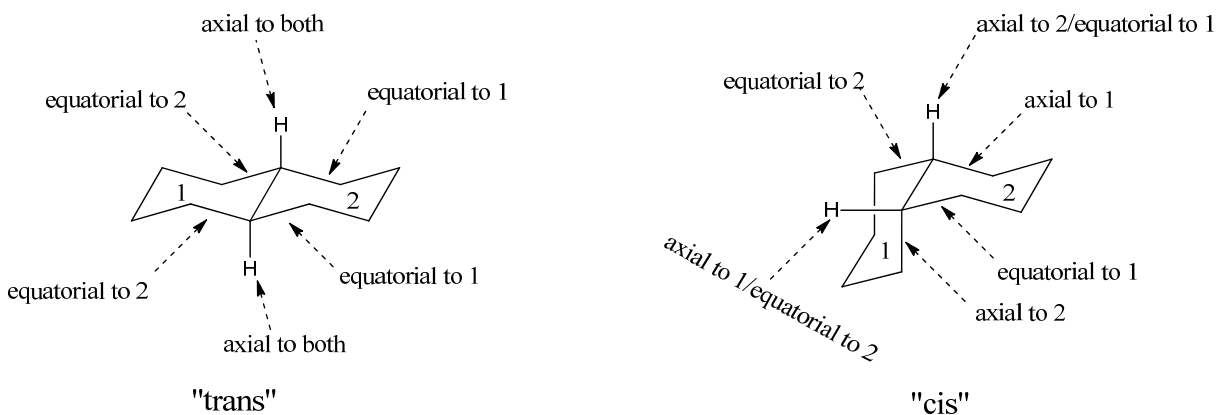

12.47

(a)  $S_N1$  mechanism:

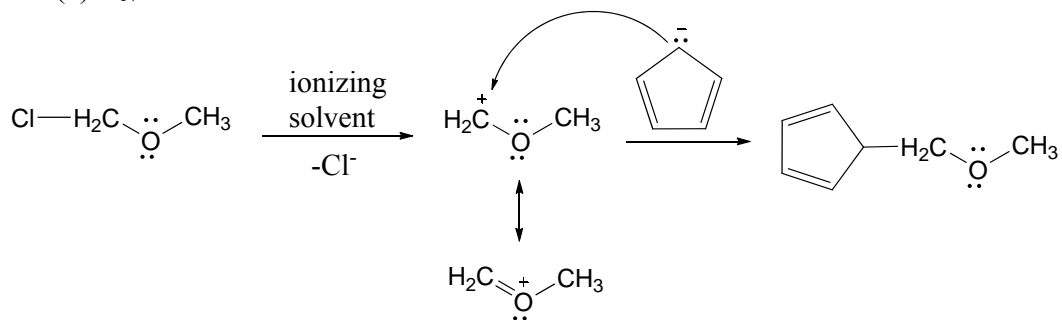

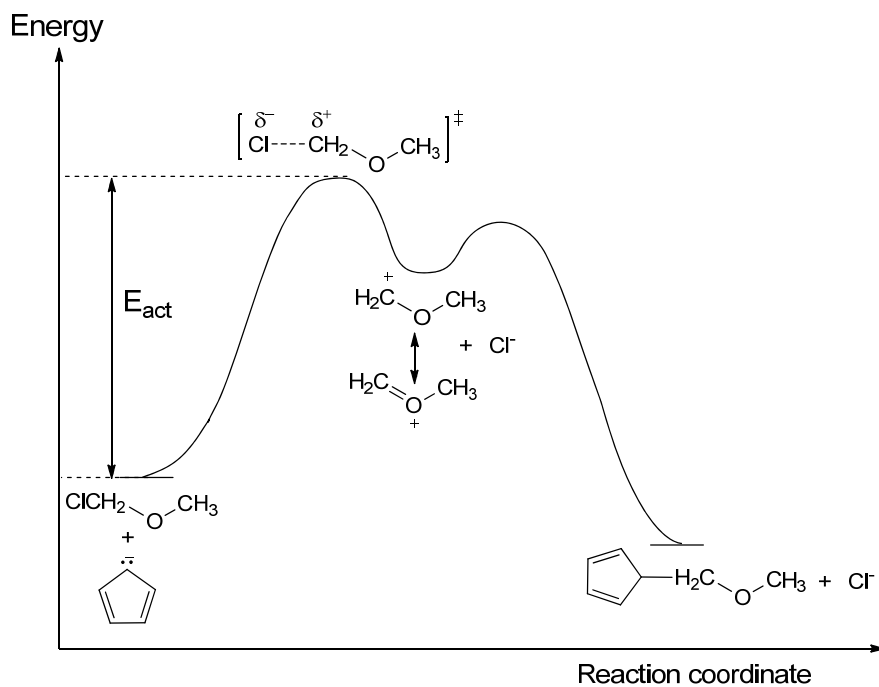

(b)  $S_N2$  mechanism:

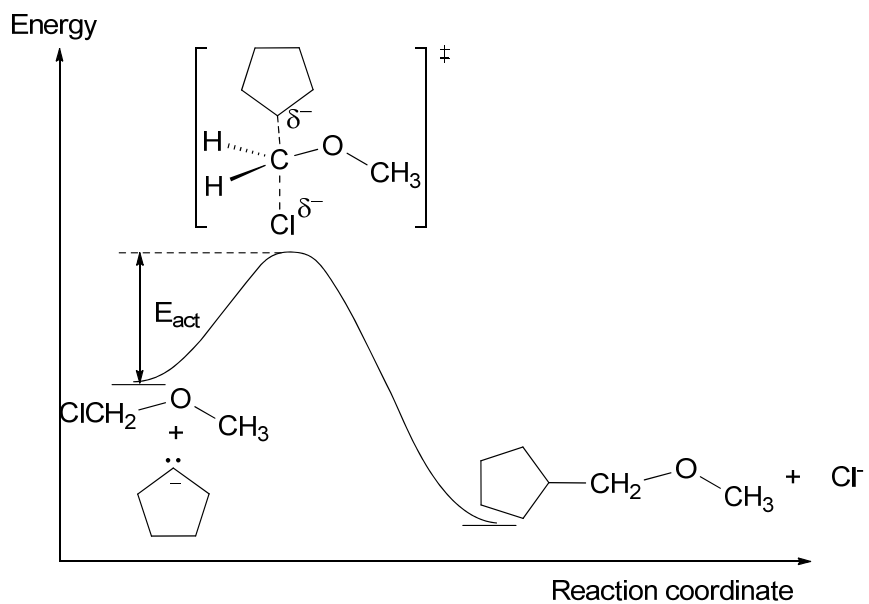
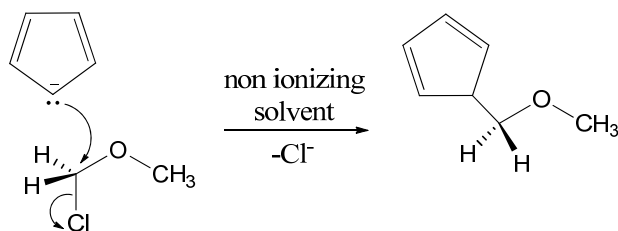



12.48

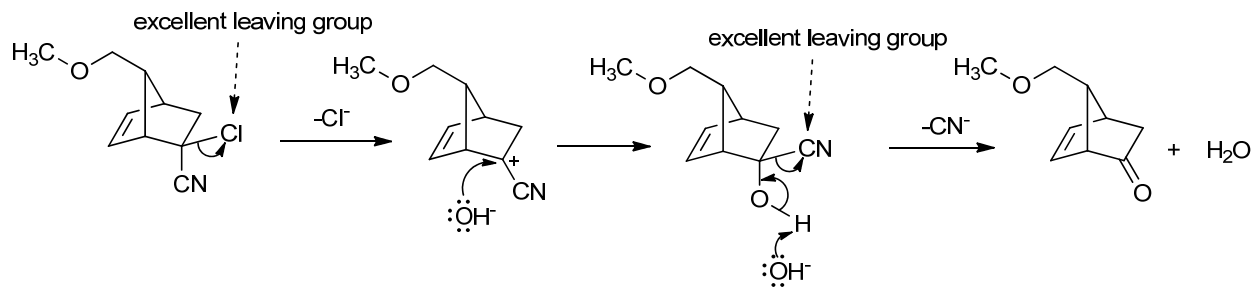

12.49

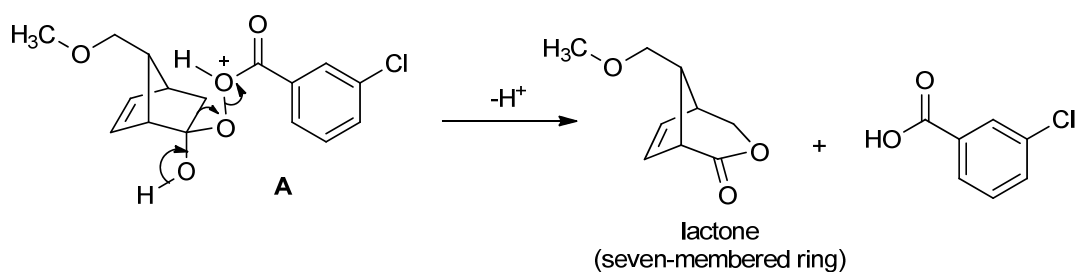

The lactone obtained through this rearrangement would also be a seven-membered ring, as shown here, but would not have involved rearrangement of the more substituted carbon-carbon bond.

12.50

Consider the comparison:

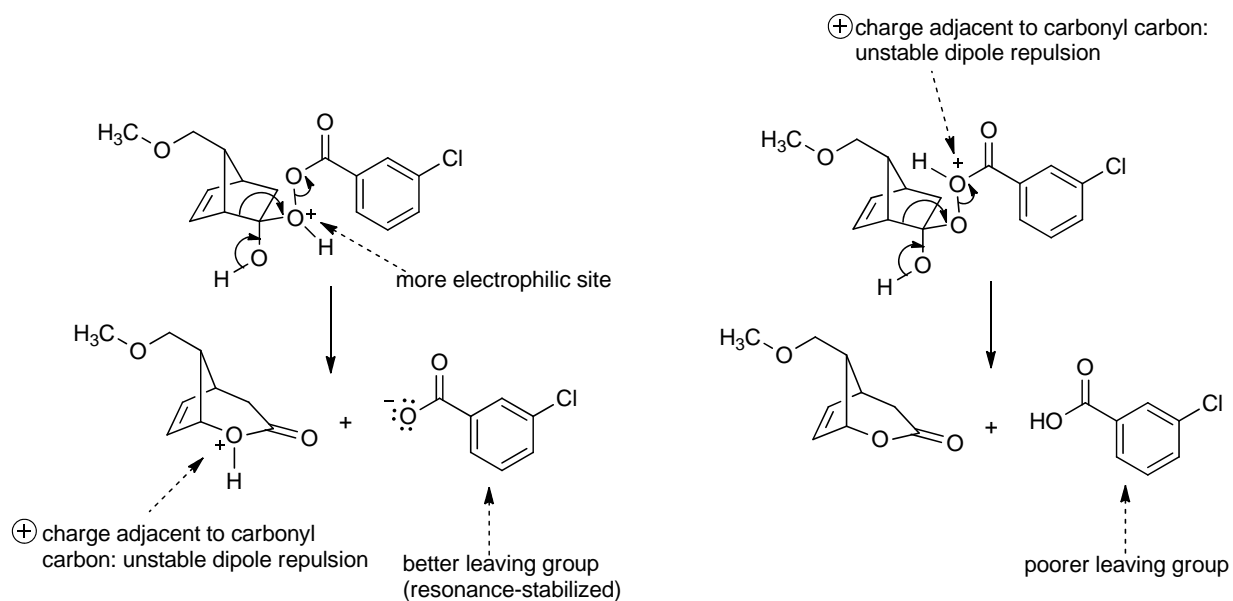

Both paths are reasonable

12.51

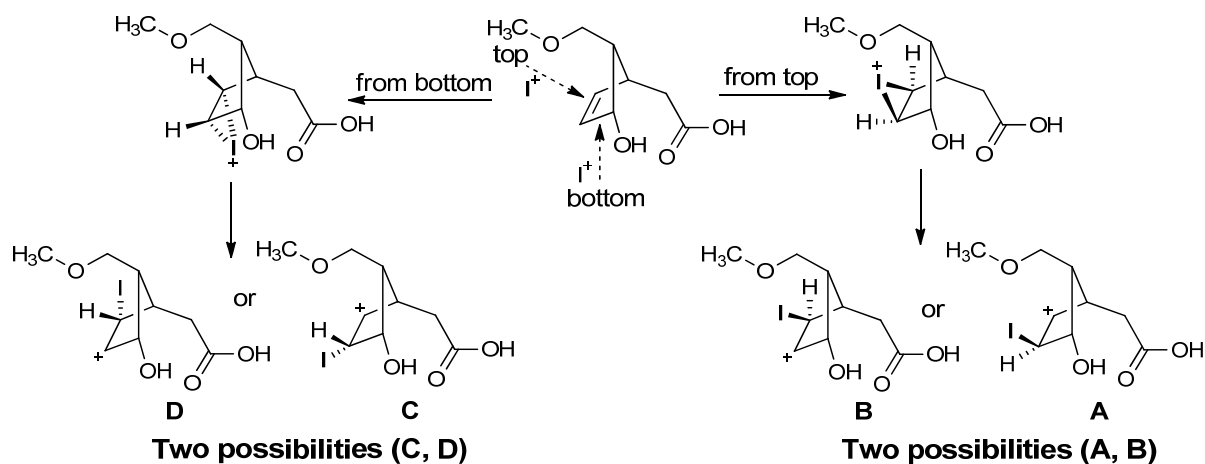

The intermediate **A** is necessary for the reaction to proceed in the direction Corey wanted with the necessary stereochemistry, as shown in Fig. 12.29 (b) and Fig. 12. 28.

12.52

-OH, hydroxyl, and -CO<sub>2</sub>H are reactive functional groups allowing for example:

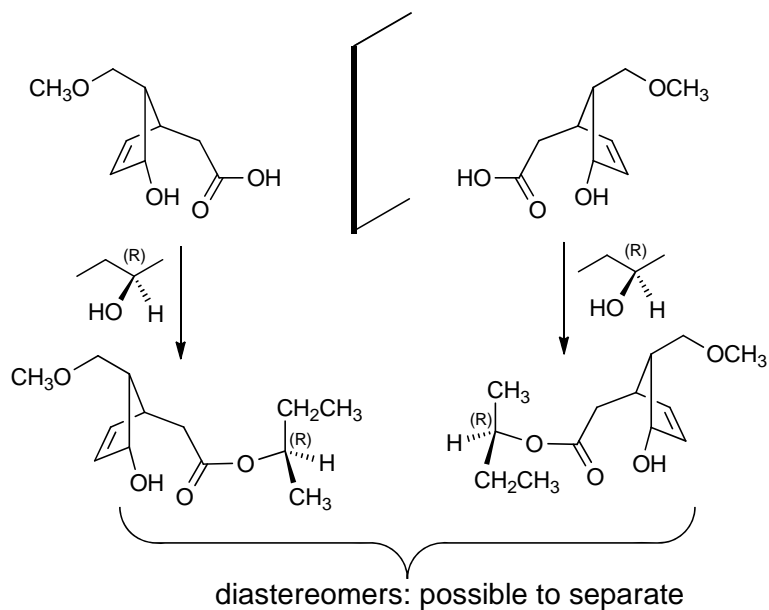

and other possibilities using, for example, chiral chromatography. See chapter 1, section 1.9.

12.53

Approach from the side opposite to the -OH and -CO<sub>2</sub>H groups will be favored to avoid steric hindrance, but there is another reason. As seen in Figures 10.10, 10.11 and 11.7, halogens add to double bonds to form three-membered rings: halonium ions as:

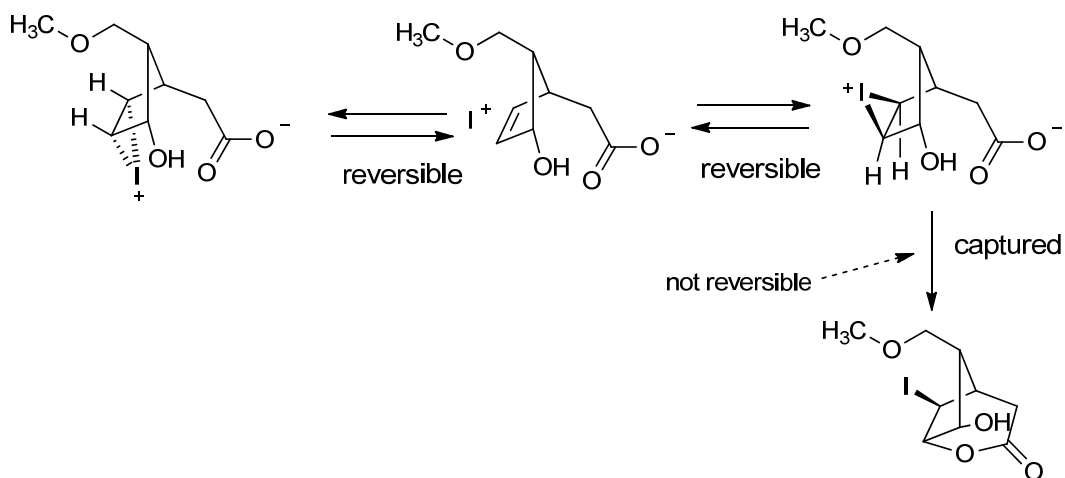

12.54

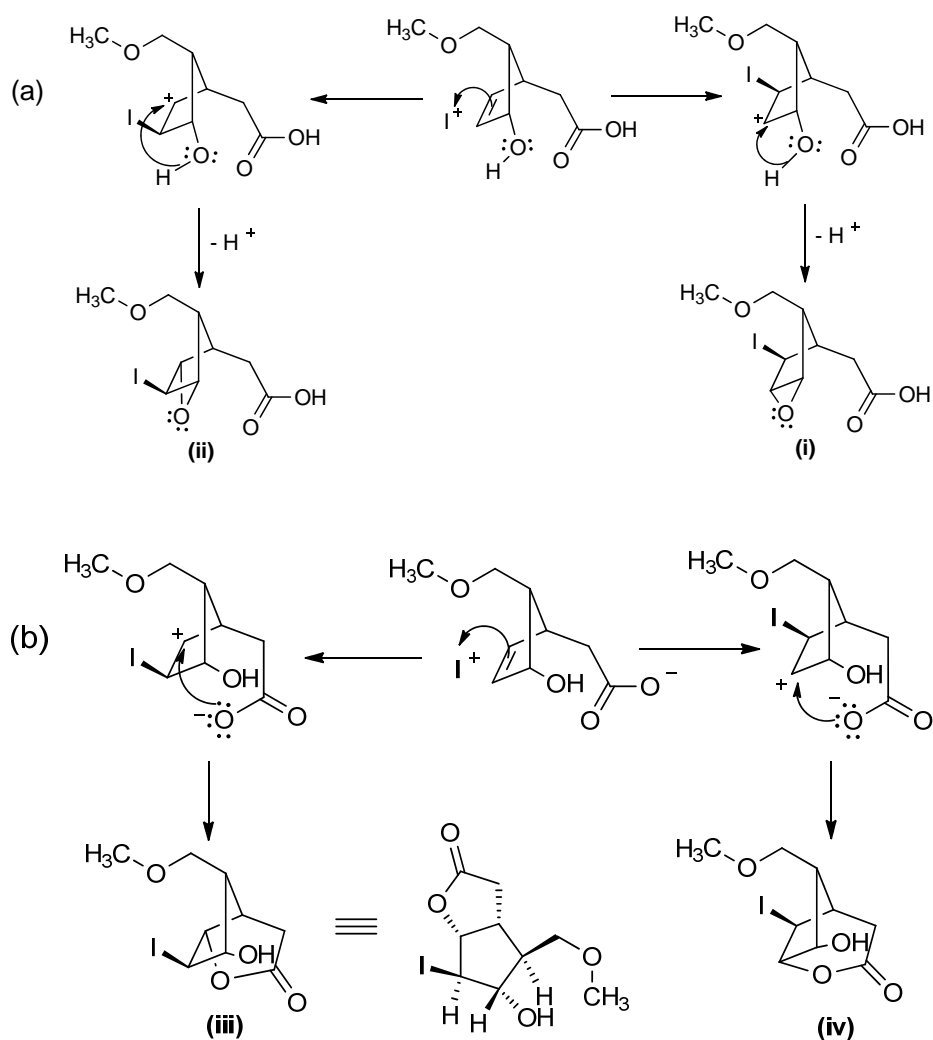

Note: see answer to problem 12.53- all these may as well involve opening of three-membered iodonium ion.

12.55

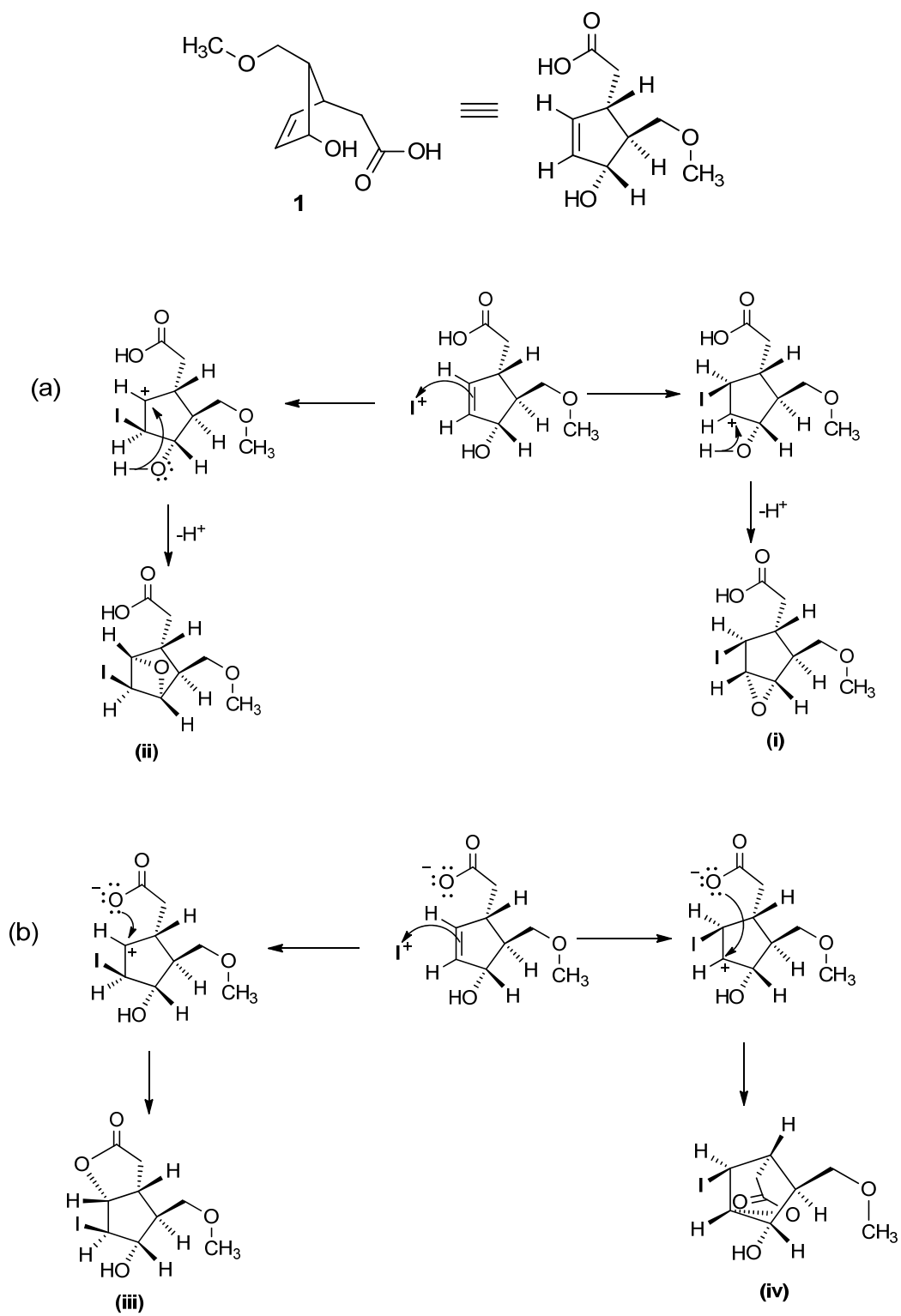

The note in the answer to problem 12.54 pertains here as well.

12.56

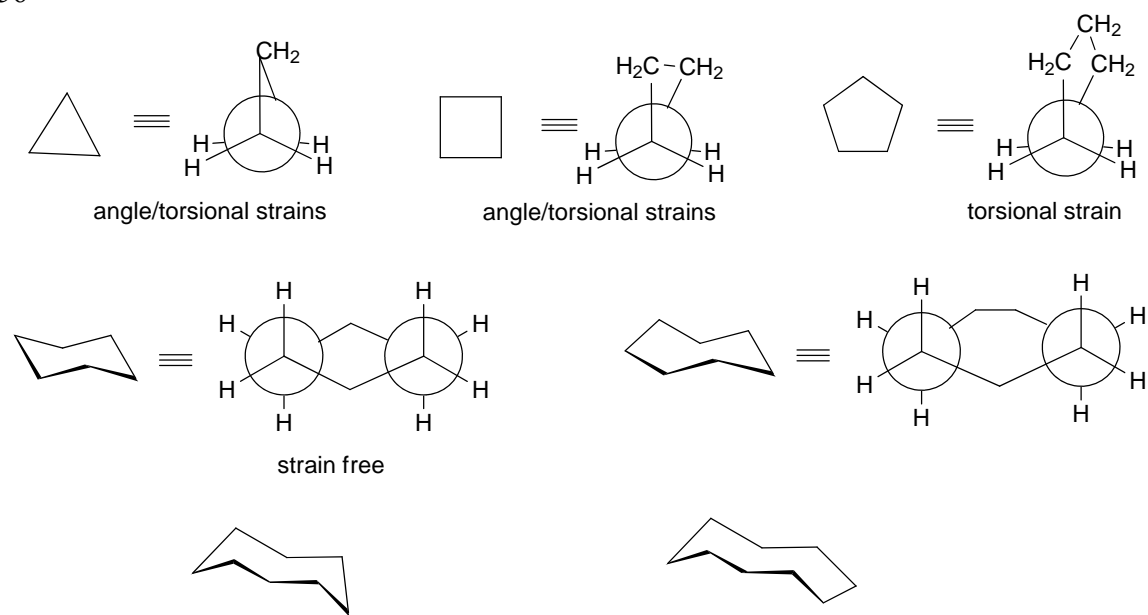

Larger rings have a "transannular" strain, where Hs across the ring are within Vanderwaals' radius of each other.

12.57

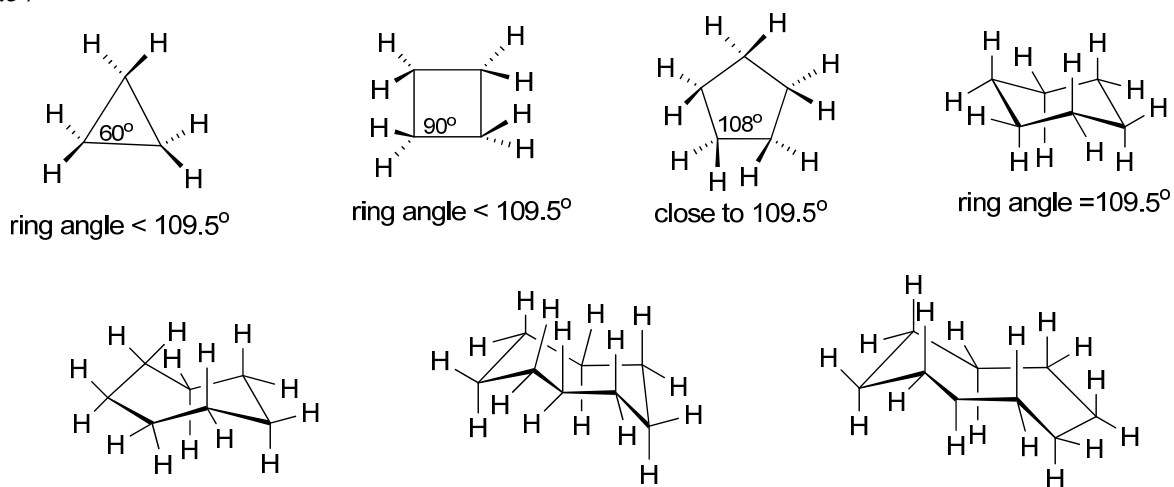

12.58

The fact that primary alkyl halides are necessary in the formation of the initial phosphonium salts in the Wittig reaction reveals that the mechanism is  $S_N2$ .

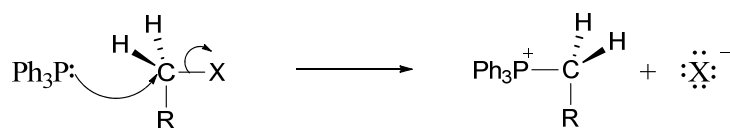

12.59

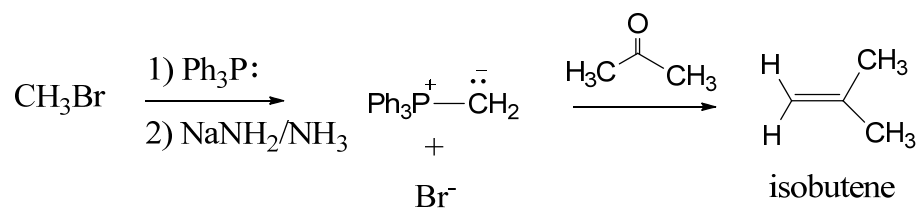

12.60

Yes. A concerted mechanism is required to obtain only the derived alkene from one oxaphosphetane. If the concerted mechanism does not occur, the carbocation intermediate derived from breaking the C-O bond would lead to a mixture of the two alkene isomers (Z, E).

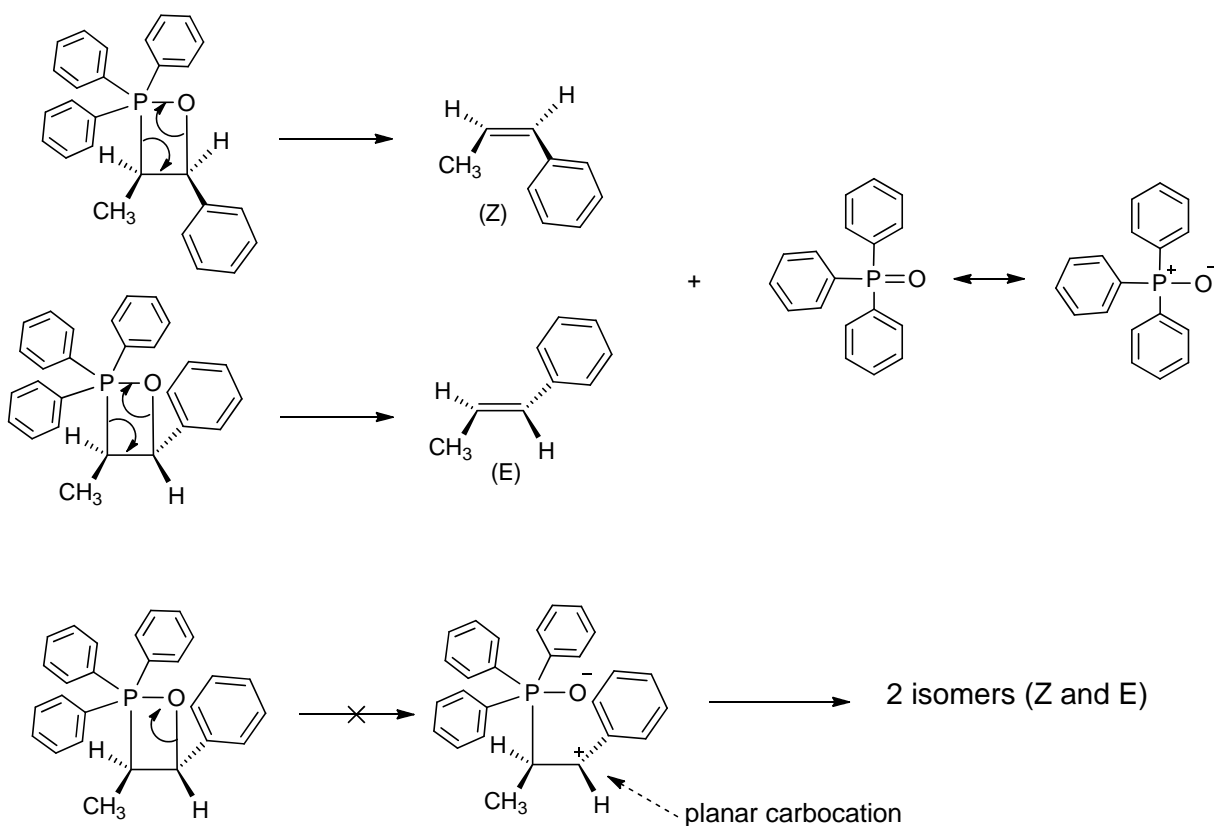

12.61

The stereochemistry of the alkene is determined by that of the betaine intermediate. Although this intermediate can, in principle, undergo conformational motions, the stereochemistry remains unaltered and ring closing, as observed in oxaphosphetane, limits the conformational motions to the eclipsed conformations shown in the answer to problem 12.62 below.

12.62

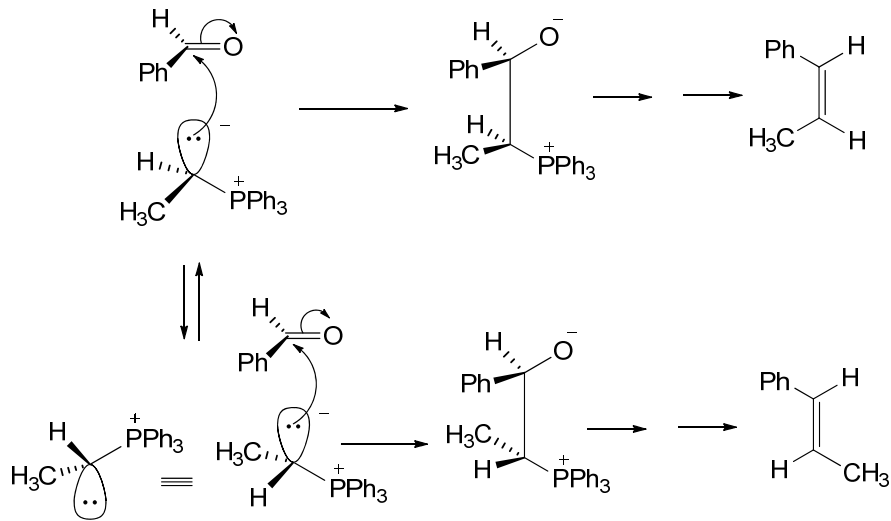

and other possibilities leading to the same two alkenes.

12.63

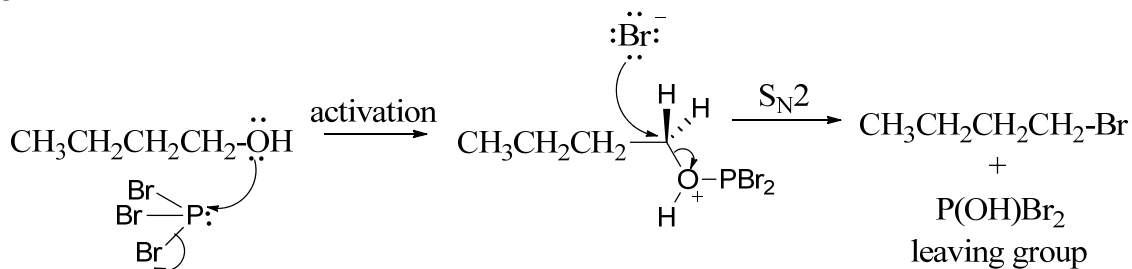

The strength of the O-P bond weakens the C-O bond which can be broken easily, making  $\text{P}(\text{OH})\text{Br}_2$  a good leaving group.

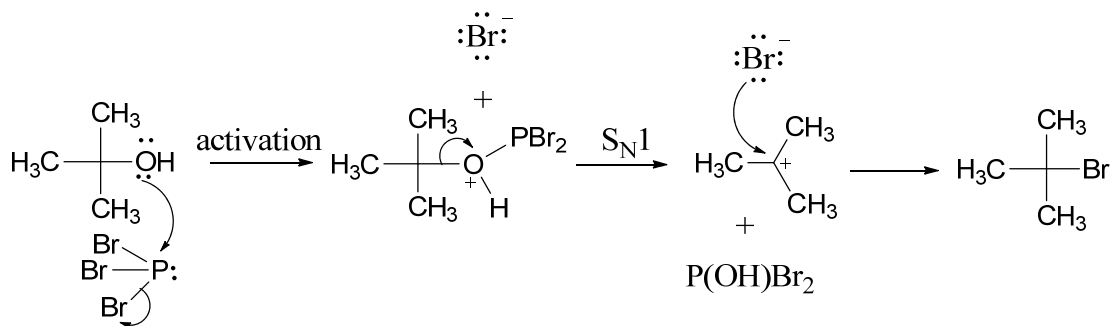

12.64

Both double-bonded carbon atoms are similar ( $-\text{CH}=\text{C}-$ ) and would have similar reactivity, leading to a mixture of isomers.

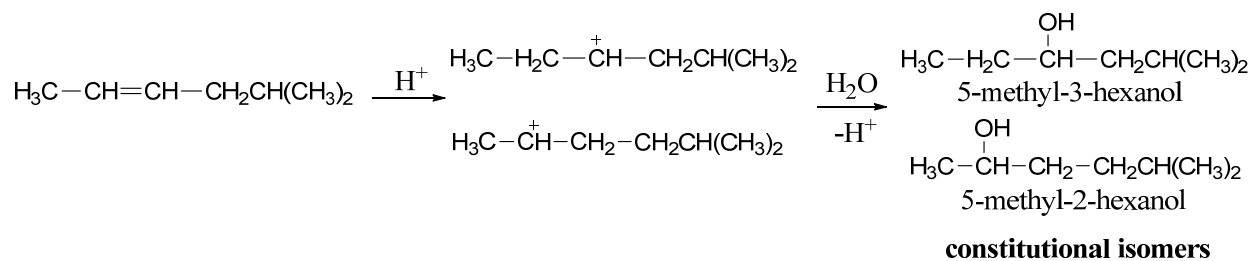

12.65

### 1) Hydroboration

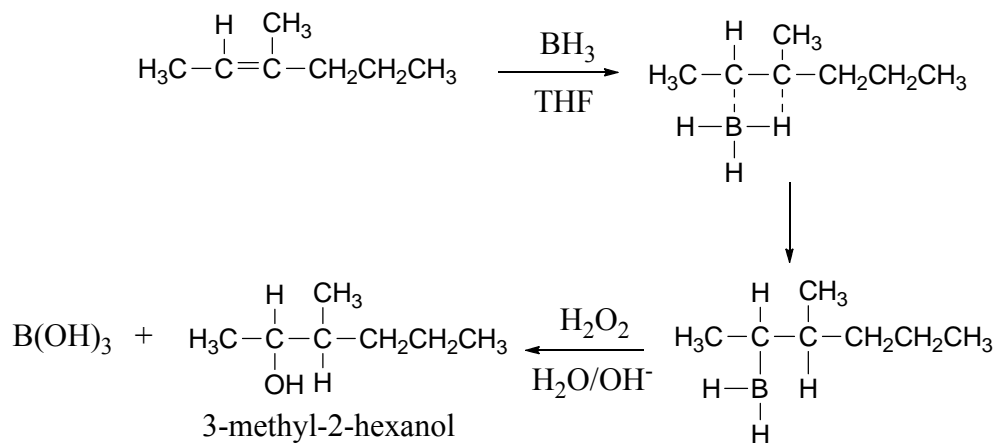

Hydroboration leads to the anti-Markovnikov's product (one isomer) because of the asymmetry of the double bond. Hydroboration is *regioselective*.

### 2) Oxymercuration-reduction

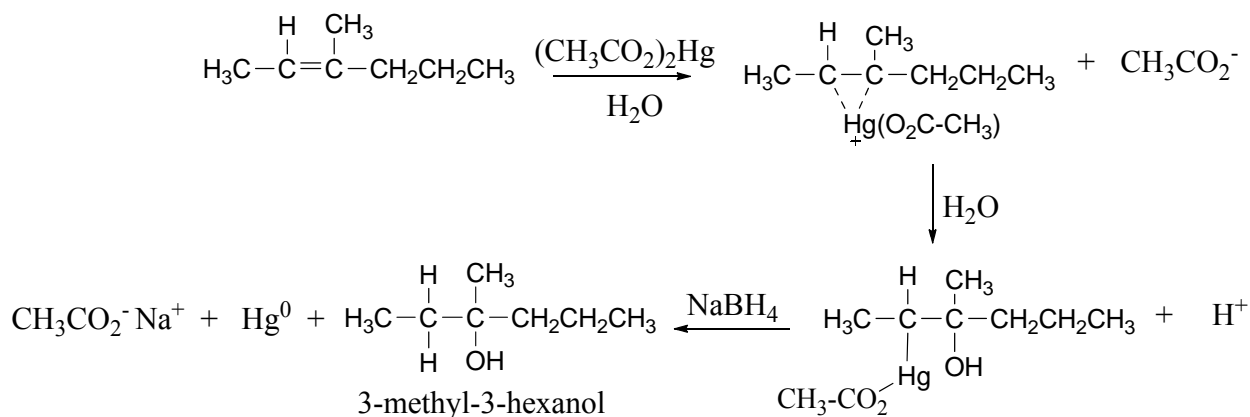

Oxymercuration leads to the Markovnikov's product (one isomer). Oxymercuration is *regioselective*.



### 3) Addition of H<sup>+</sup>/H<sub>2</sub>O

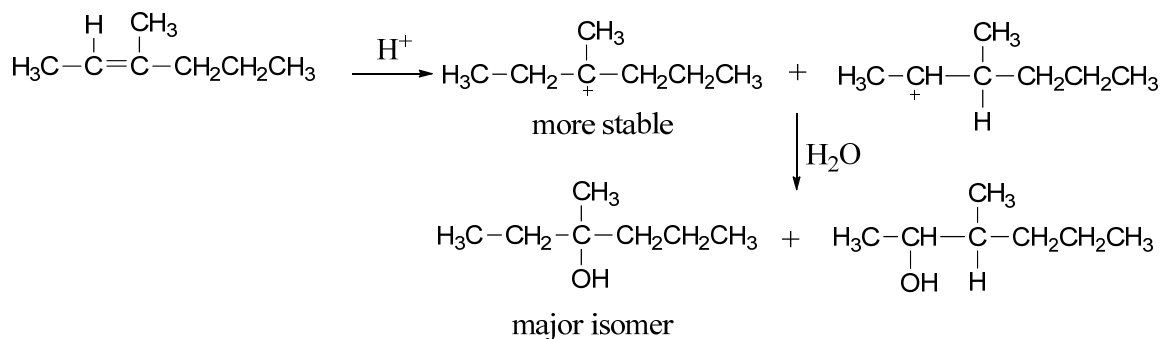

Addition of H<sup>+</sup>/H<sub>2</sub>O is less *regioselective*.

12.66

(a) Synthesis of CH<sub>3</sub>-CH=CH-CH<sub>2</sub>CH(CH<sub>3</sub>)<sub>2</sub>

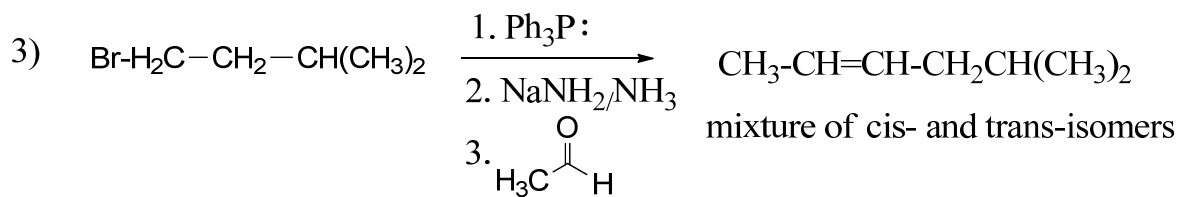
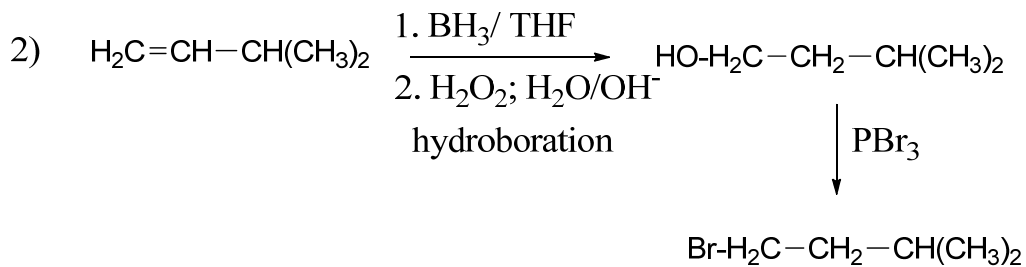
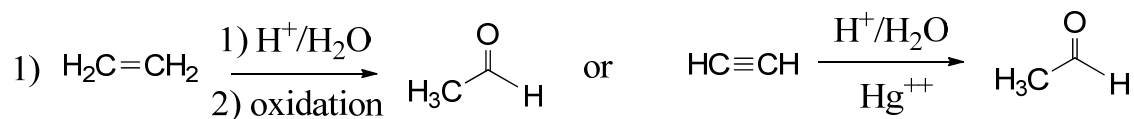

Wittig reaction

(b) Synthesis of  $\text{CH}_3\text{-CH=C(CH}_3\text{)-CH}_2\text{CH}_2\text{CH}_3$

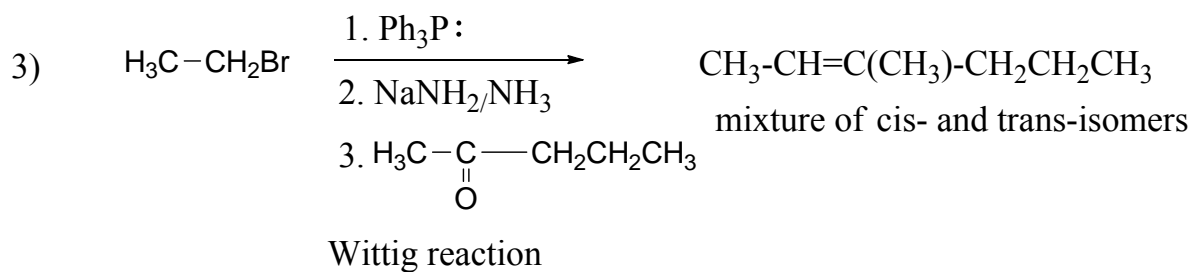
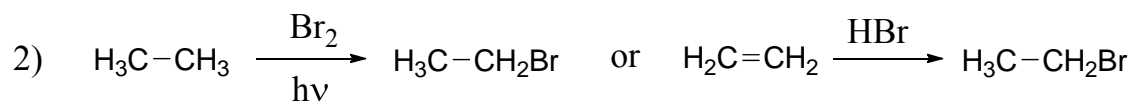
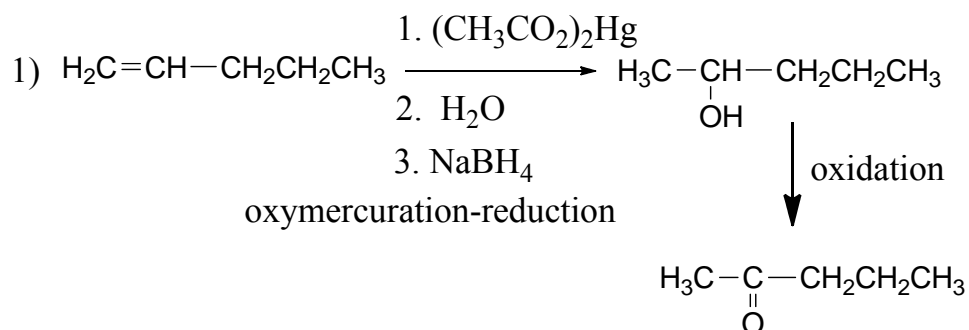

12.67

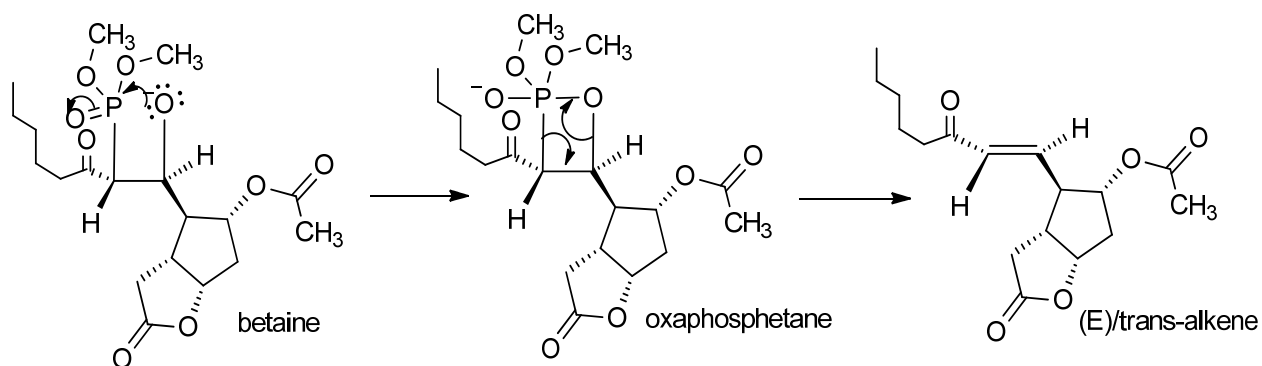

12.68

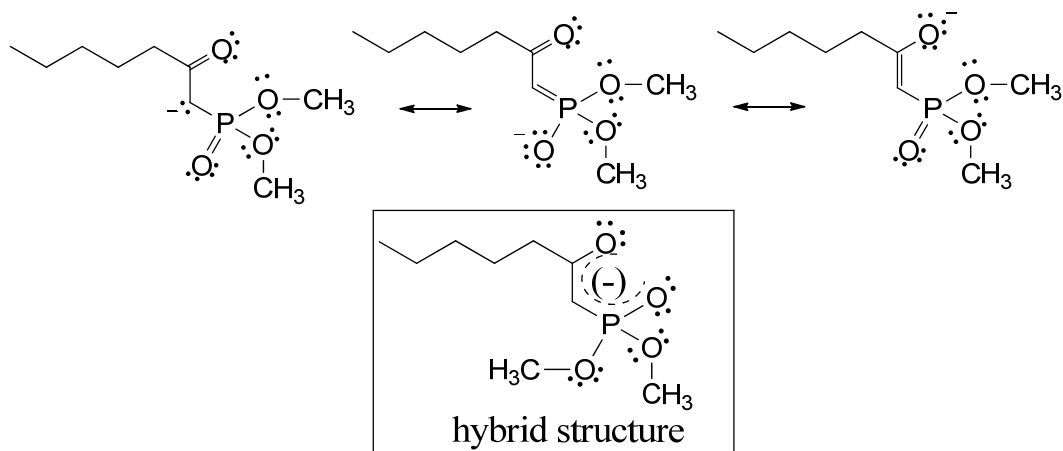

12.69

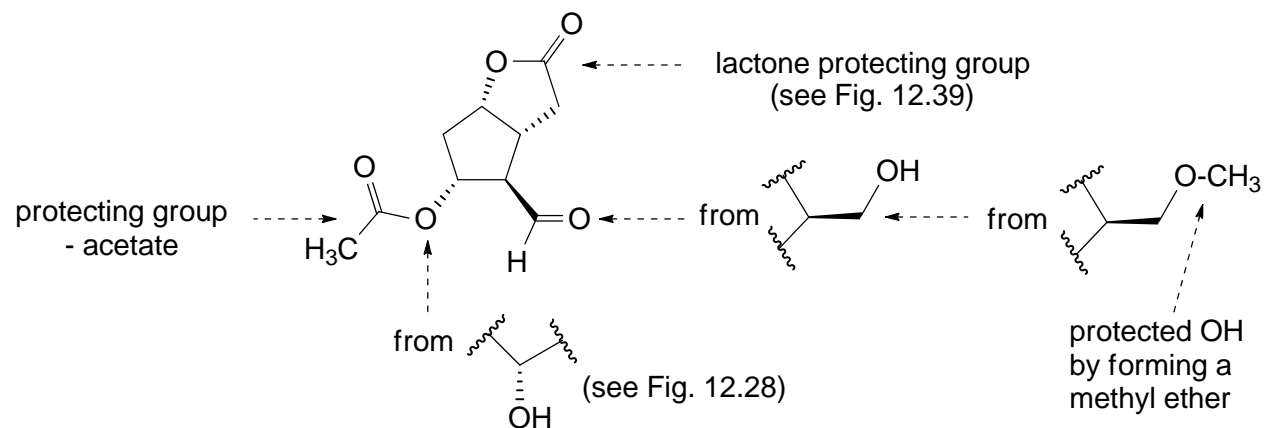

12.70

(a) other active hydrogen sources are:

- alcohols (R-OH)
- acids (R-CO<sub>2</sub>H, H<sub>2</sub>SO<sub>4</sub>, HX, etc.)
- ammonium salts (NH<sub>4</sub><sup>+</sup>, R-NH<sub>3</sub><sup>+</sup>)

(b) other reactions sensitive to the presence of active hydrogen are:

- reduction with reducing agent such as LiAlH<sub>4</sub>, NaBH<sub>4</sub>, etc.
- Grignard reaction
- Reactions involving carbanions such as Aldol and Claisen condensations.

12.71

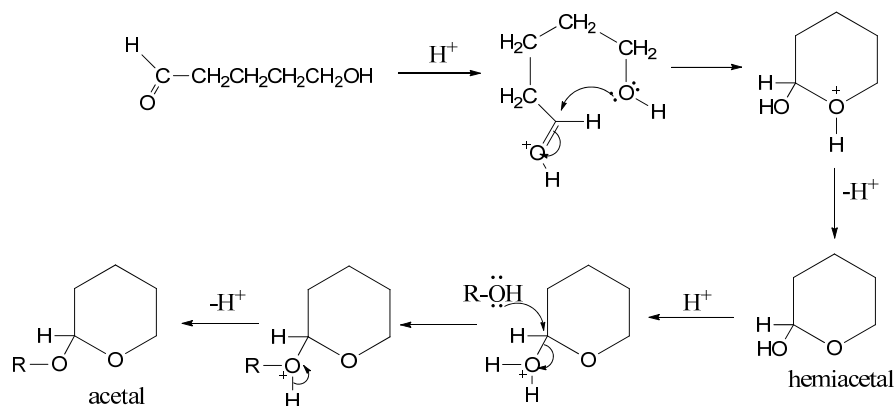

12.72

The reversibility of the steps shown could be avoided by increasing the concentration of the unprotected intermediate which will result in shifting the equilibria towards the product.

12.73

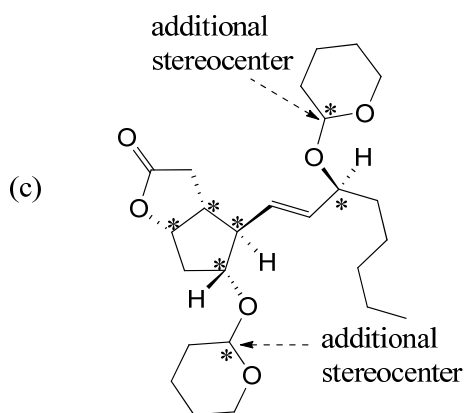
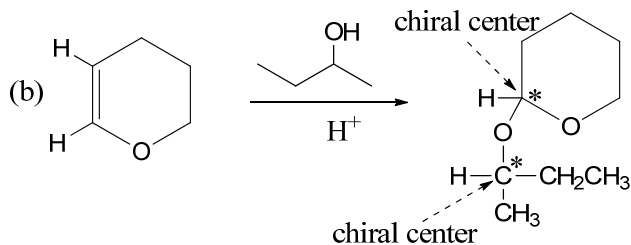
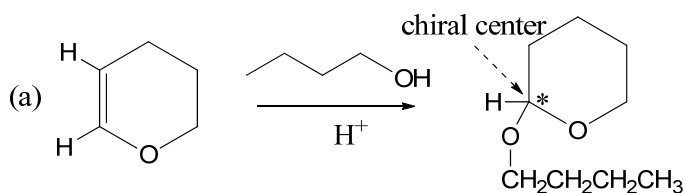

12.74

$\text{LiAlH}_4$  (lithium aluminum hydride) is a stronger reducing agent than DIBAL (diisobutyl aluminum hydride) and would convert the lactone to the alcohol and carboxylate anion **1**, and then to the primary alcohol **2**.

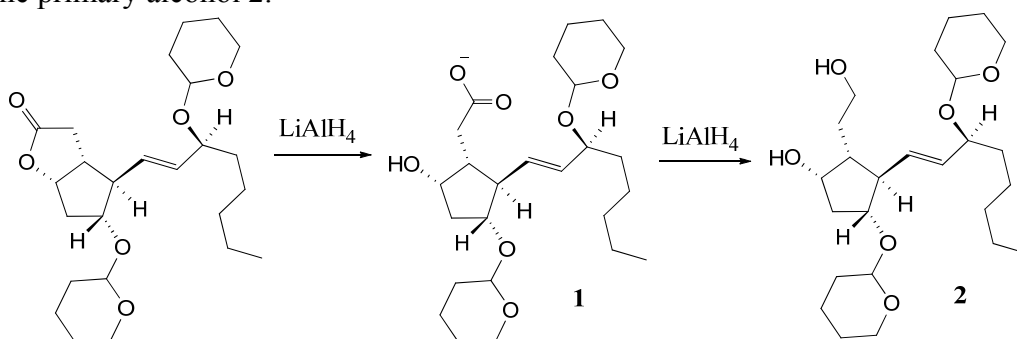

12.75

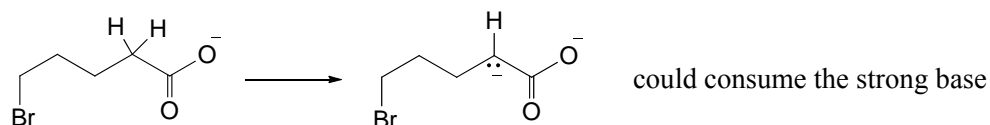

12.76

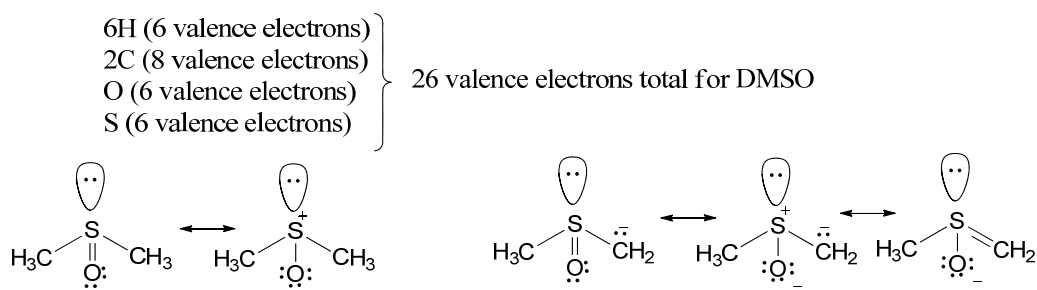

12.77

$^{15}\text{P}$  (15 valence electrons):  $1s^2 2s^2 2p^6 3s^2 3p^3$

hybridized P atom:  $1s^2 2s^2 2p^6 3s^1 3p^3 3d^1$

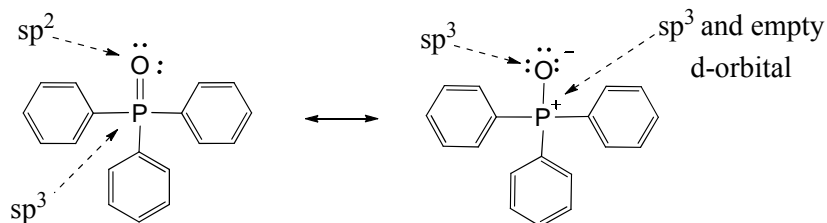

- hybridization:  $sp^3$
- geometry: approximately tetrahedral
- the 3d orbital forms a p-bond with a  $sp^2$  orbital of the oxygen atom

- hybridization:  $sp^3$
- geometry: approximately tetrahedral
- the 3d orbital is empty

12.78

The synthesis of Prostaglandin E<sub>2</sub> could be achieved by altering the synthesis in Fig. 12.40 as follows:

1. Oxidation of the product of step 3 (Fig. 12.40)
2. Removal of the actual protecting groups.

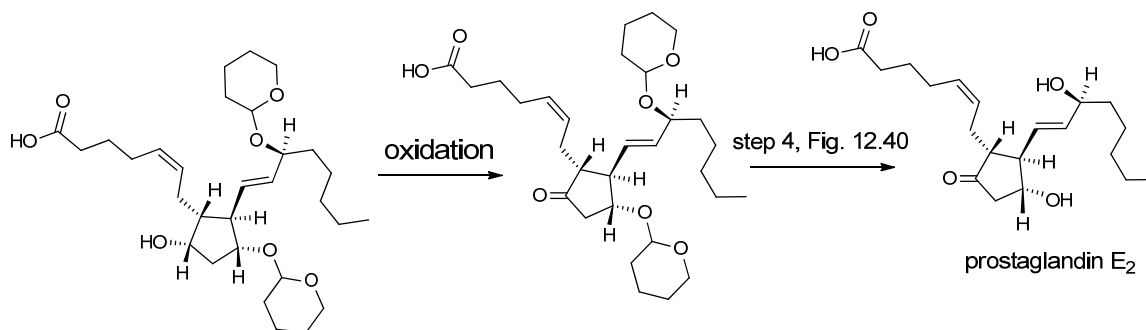

from step 3, Fig. 12.40

12.79

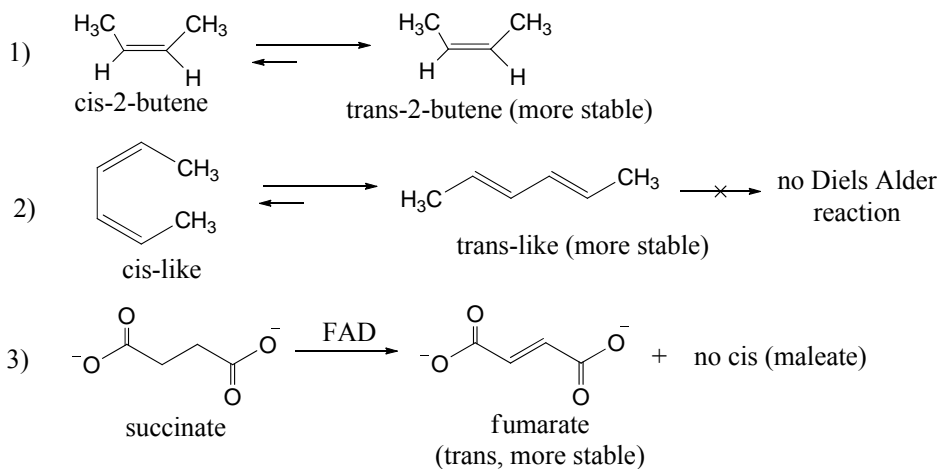

4) However in unsaturated fatty acids, less stable cis double bonds are favored as is the situation also for natural rubber (section 11.3).

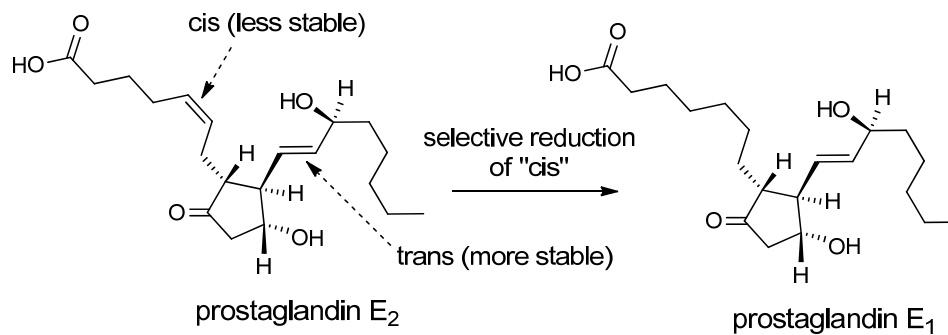

The cis-alkene is less stable than the trans-alkene and may be selectively reduced under certain conditions leaving the trans-double bond unaltered. The energy of activation of the reaction will be less to reduce the cis-double bond if the double bond stability is the controlling factor.

12.80

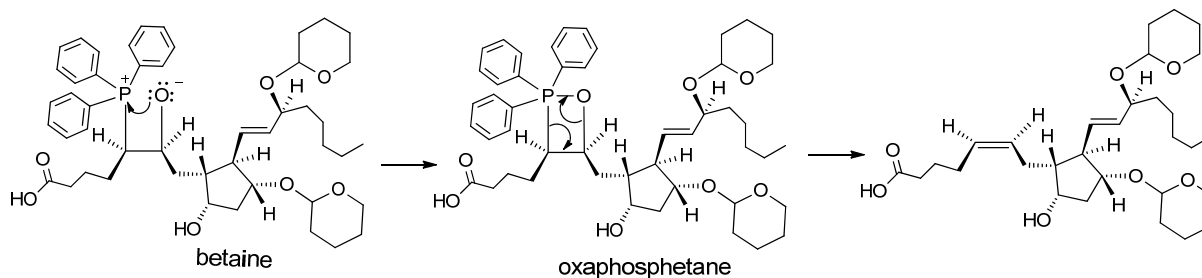

12.81

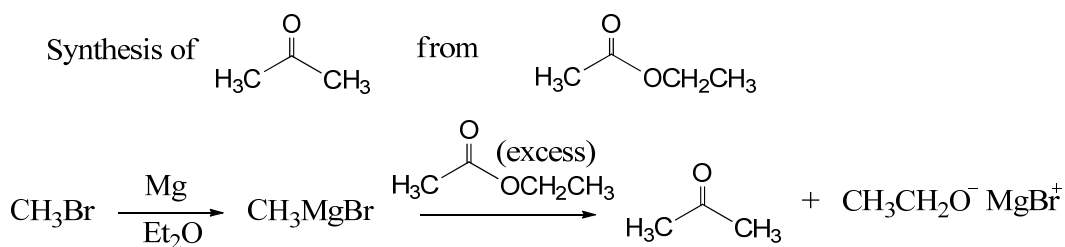

12.82

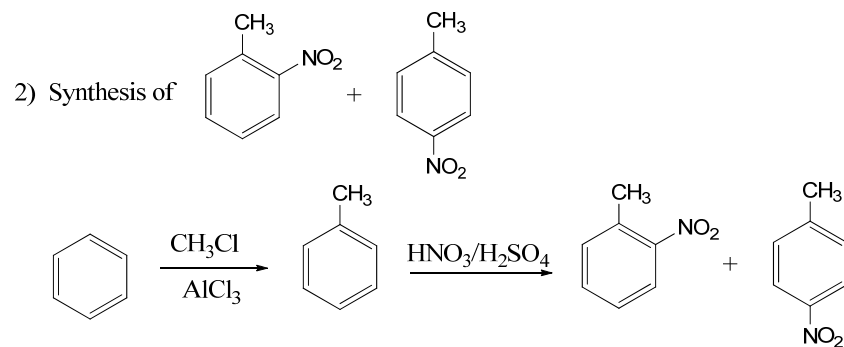
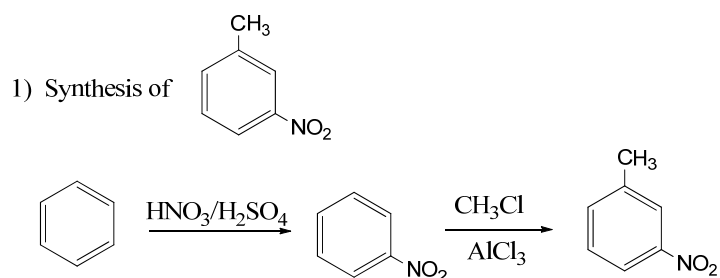

12.83

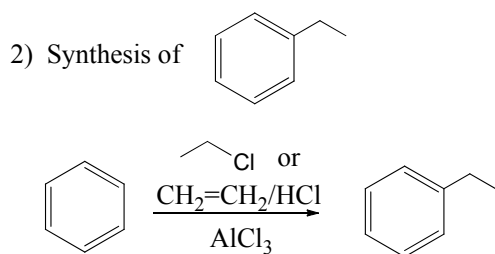
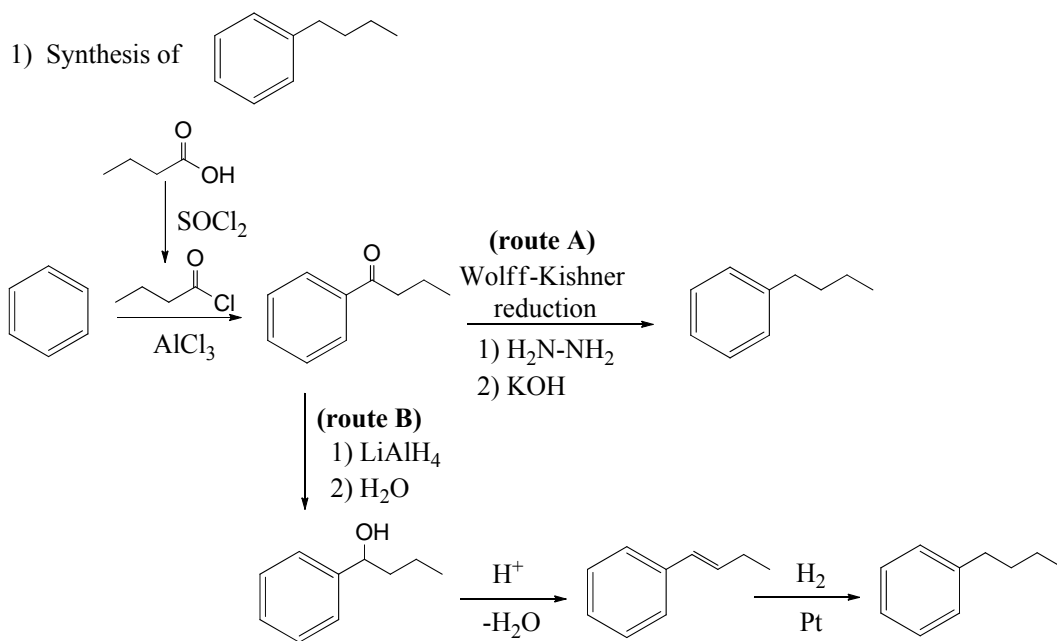

12.84

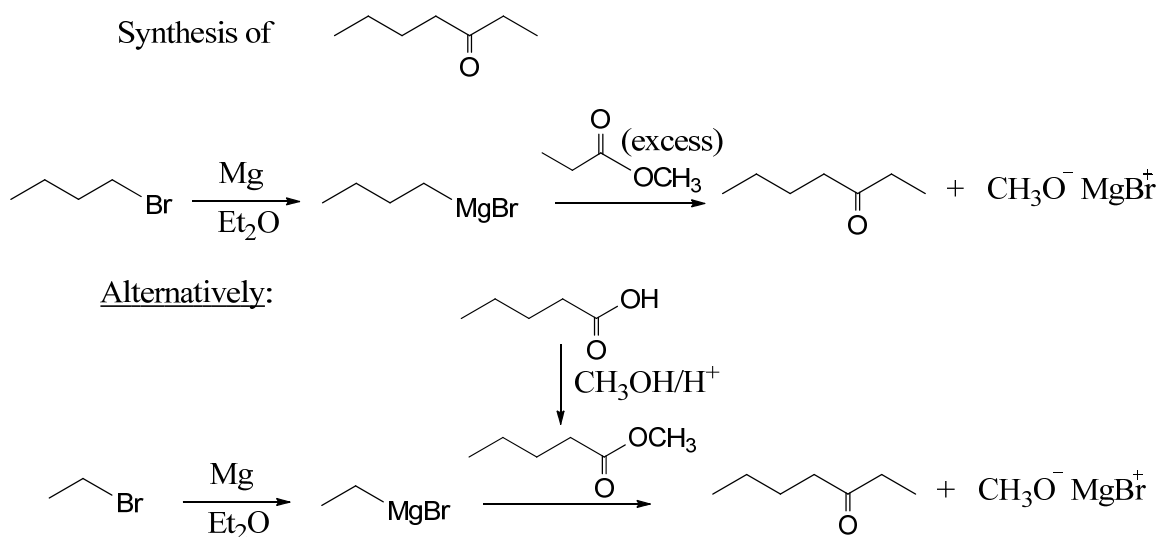



12.85

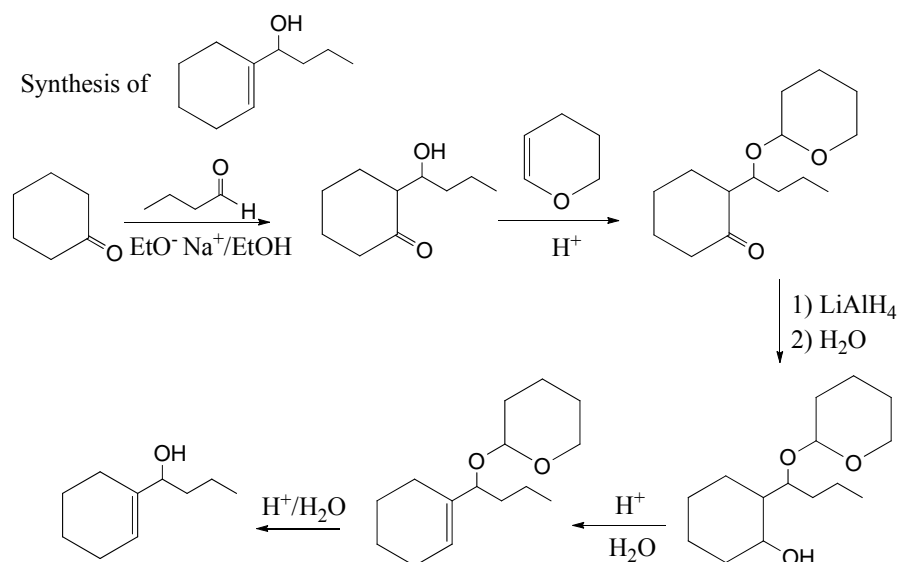

12.86

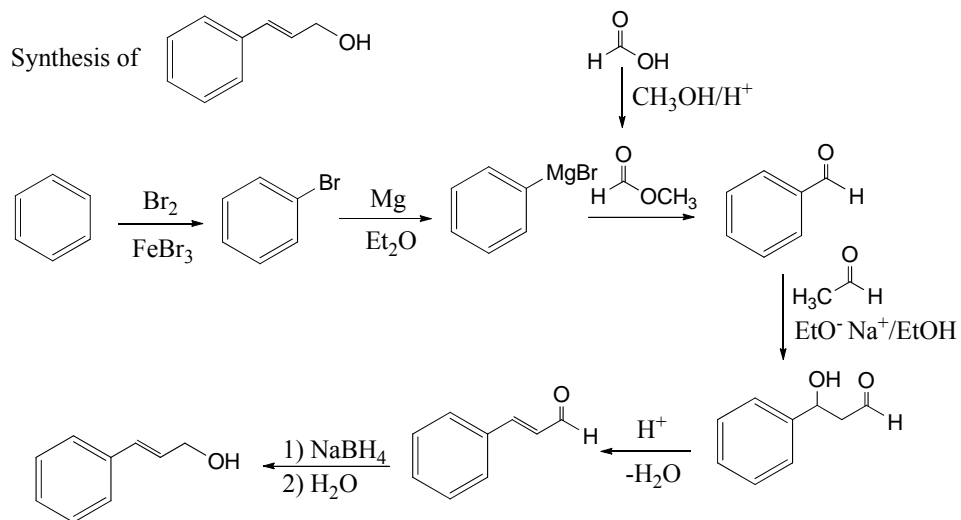

12.87

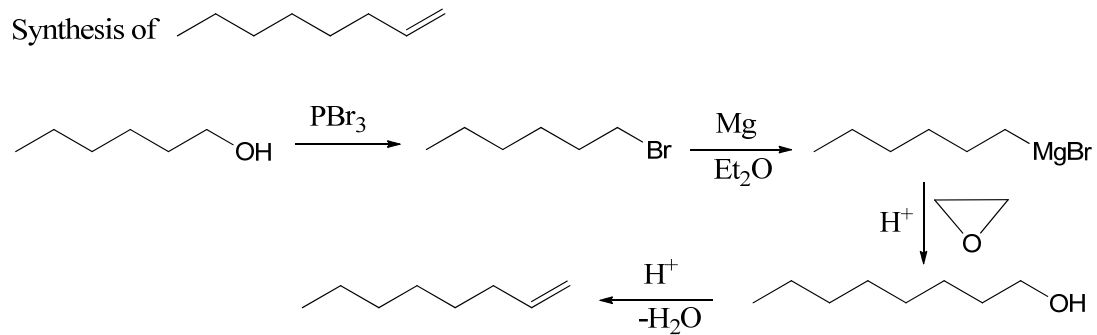

12.88

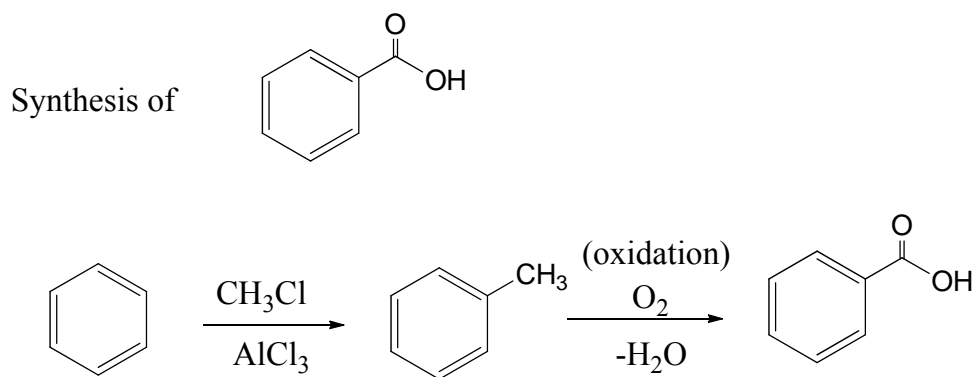
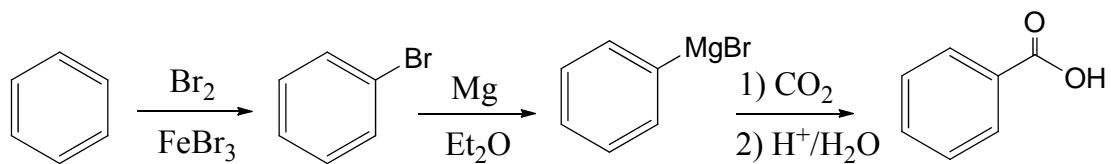
Alternatively:

12.89

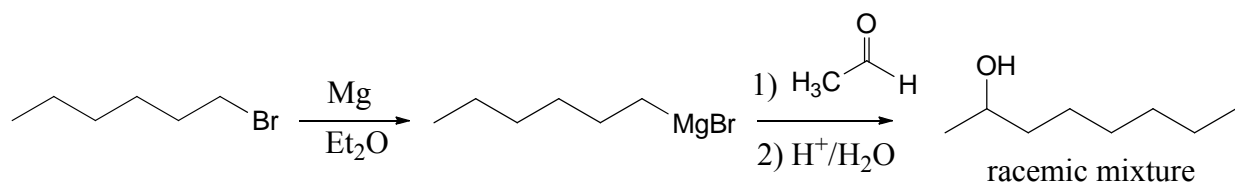
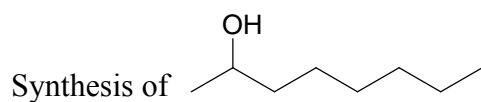

12.90

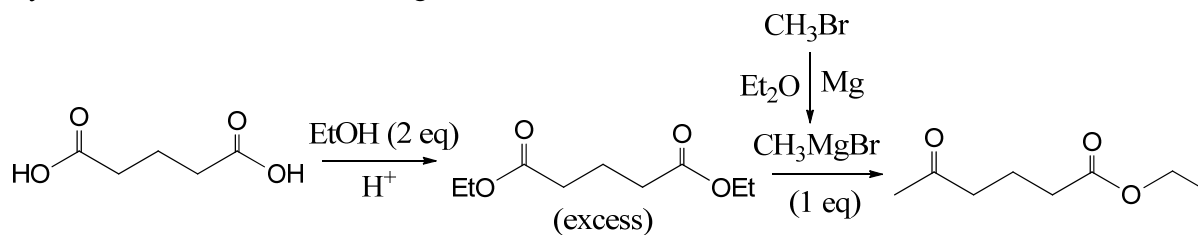
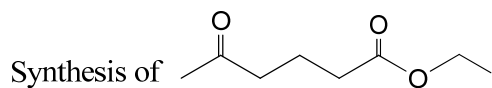

12.91

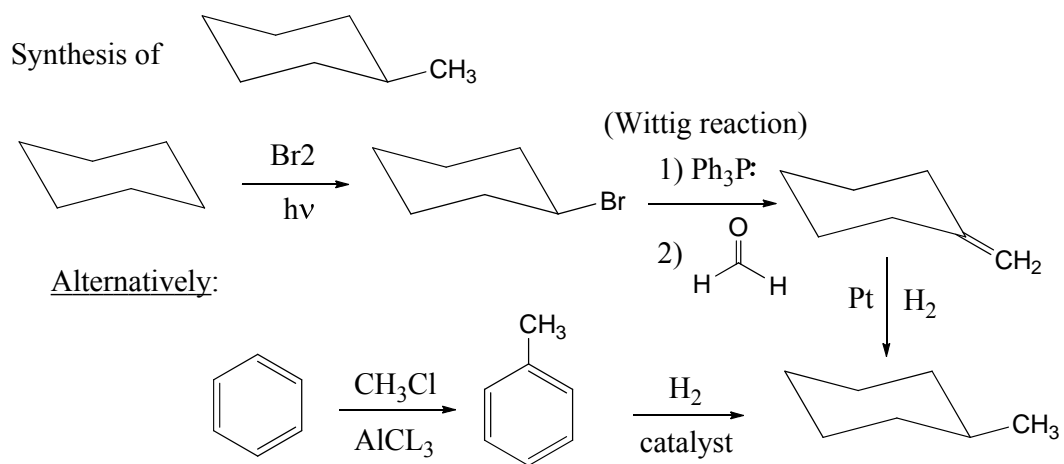

12.92

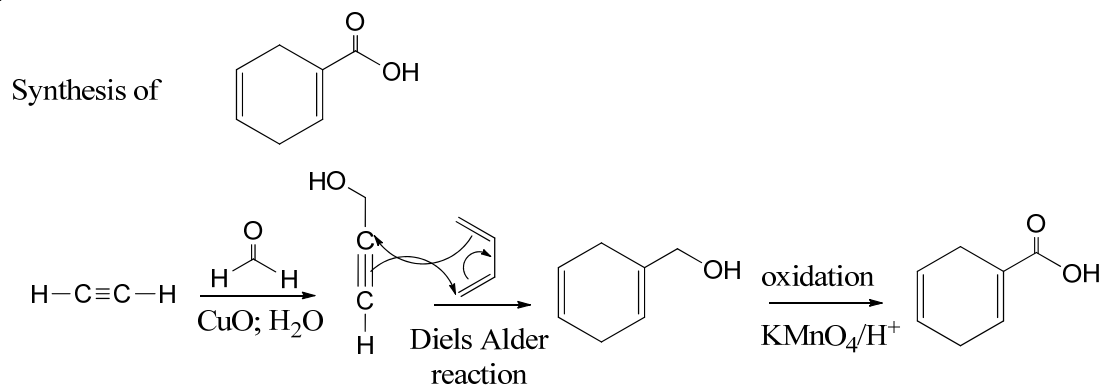

12.93

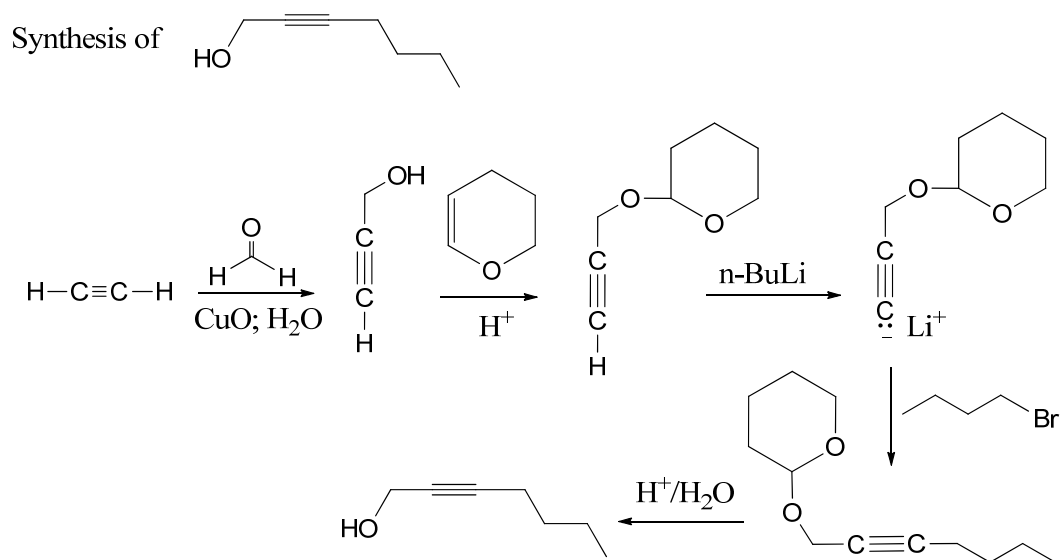

12.94

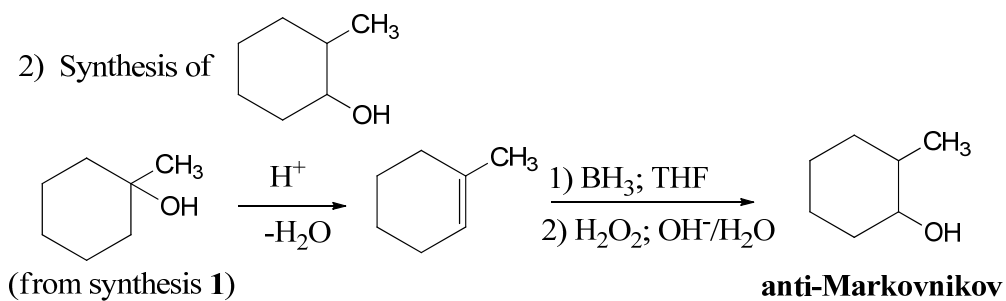
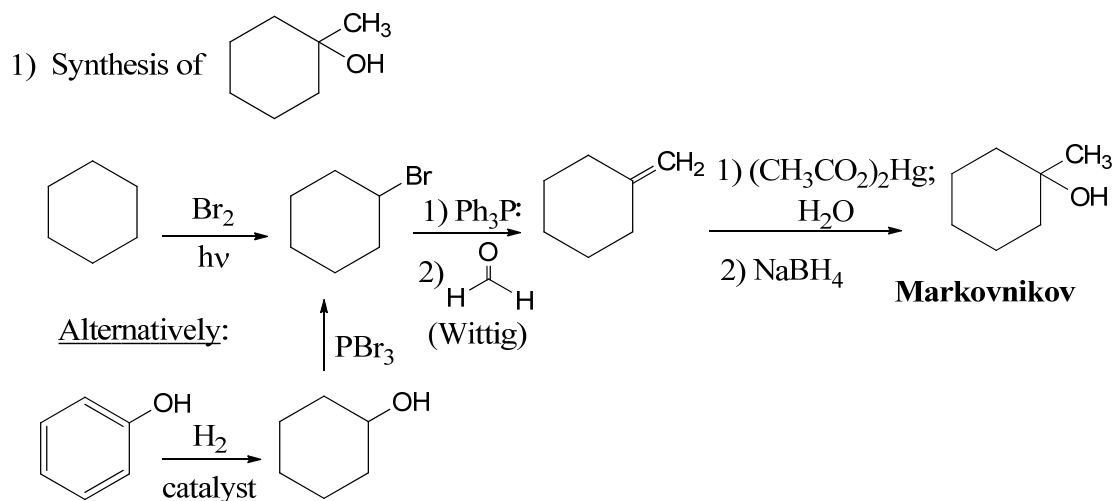

12.95

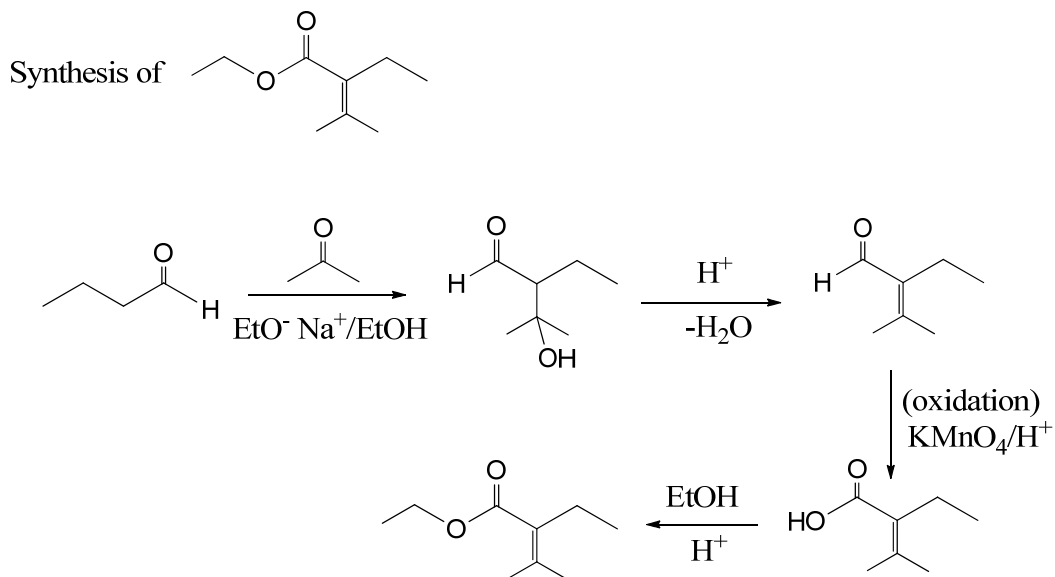

12.96

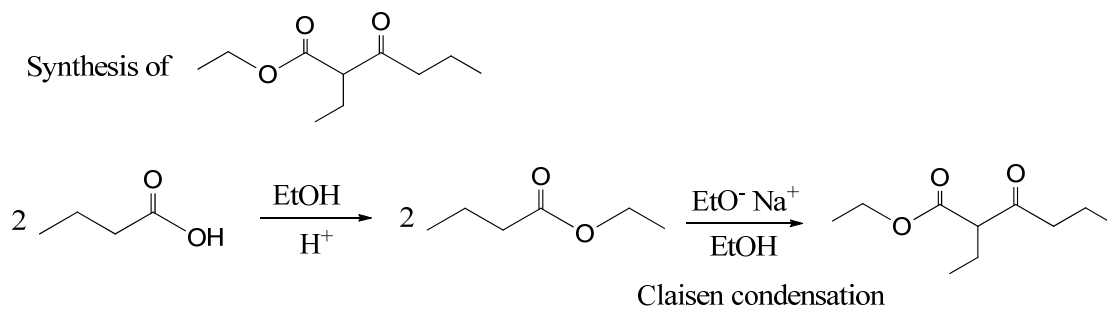

12.97

A photochemical process can convert the HOMO,  $\Psi_1$ , of one molecule of ethylene to a new HOMO (excited molecule; HOMO\*),  $\Psi_2$ , which has one node, and therefore capable of interacting with the LUMO,  $\Psi_2$  of another molecule of ethylene.

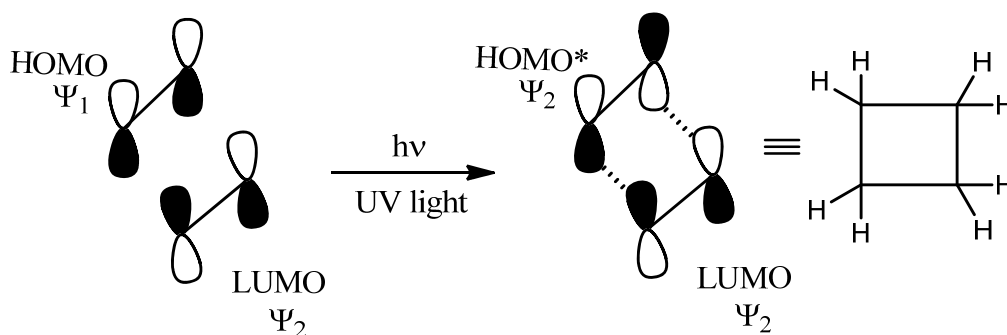

12.98

In reaction 1, rearrangement involves a carbocation and a propylene anion while in reaction 2, a carbocation and a 1,3-pentadiene anion are involved.

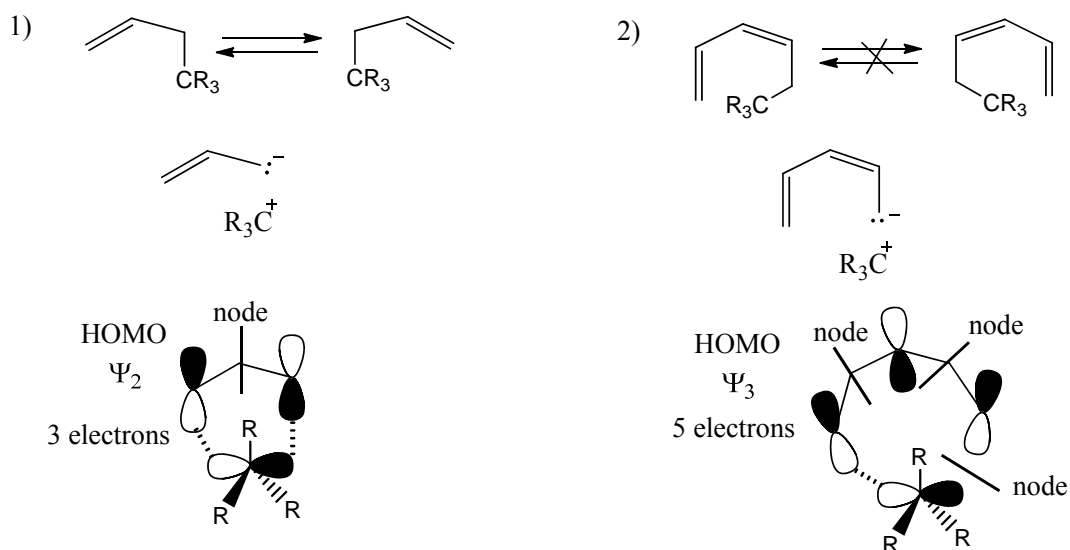

12.99

Consider the following synthesis of Vitamin D<sub>3</sub> and let's examine here only reaction **1** (photochemical process; 6 electrons). Reaction **2** is a [1,7]-sigmatropic transfer of a hydrogen atom, which is discussed in the answer to problem 12.100.

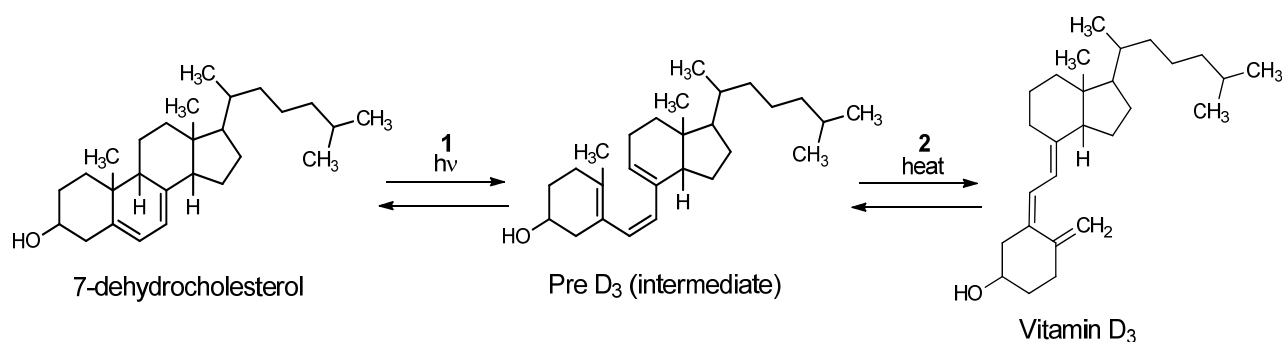

UV radiation converts HOMO,  $\Psi_3$  (6 electrons) to HOMO\*,  $\Psi_4$ . Therefore, reaction **1** (retro-Diels-alder reaction) undergoes a 6-electron “conrotatory” arrangement.

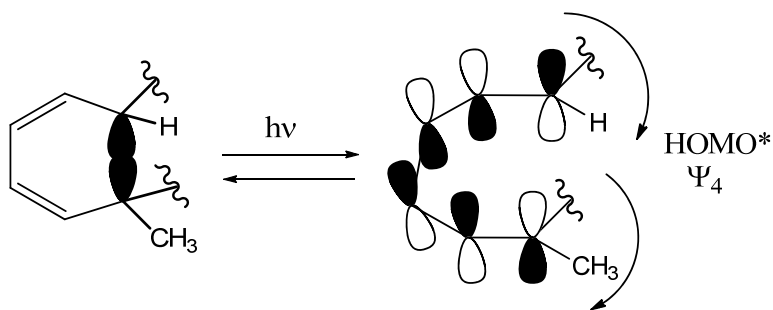

In contrast, in the presence of heat, reaction **1** would undergo “disrotatory” arrangement as follows:

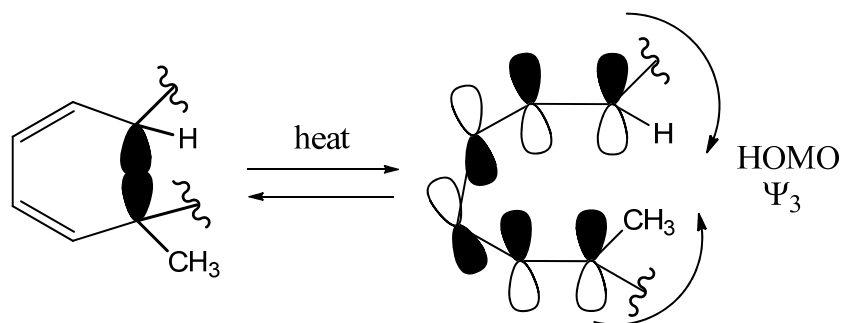

12.100

Sigmatropic rearrangement of a hydrogen atom from C-7 to C-1 of 1,3,5-heptatriene involves a hydrogen atom and a 1,3,5-heptatriene radical (7 electrons).

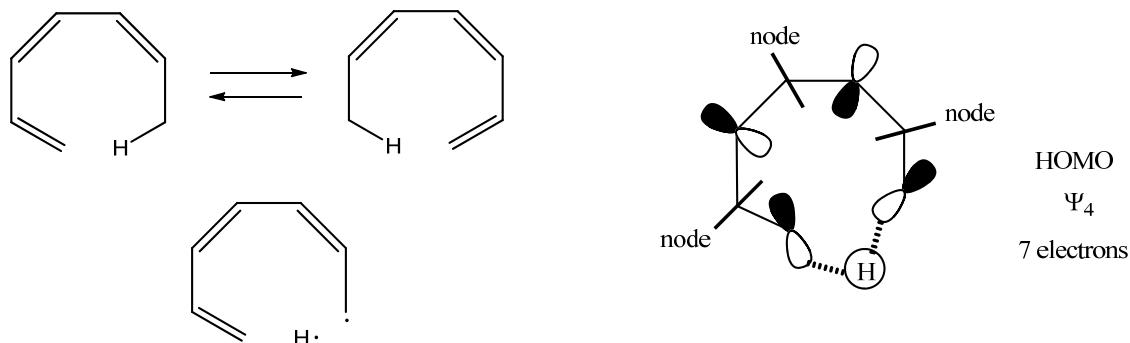

Another example of a sigmatropic rearrangement of a hydrogen atom is the thermal conversion of pre D<sub>3</sub> intermediate to vitamin D<sub>3</sub> (see step 2 in problem 12.99).

12.101

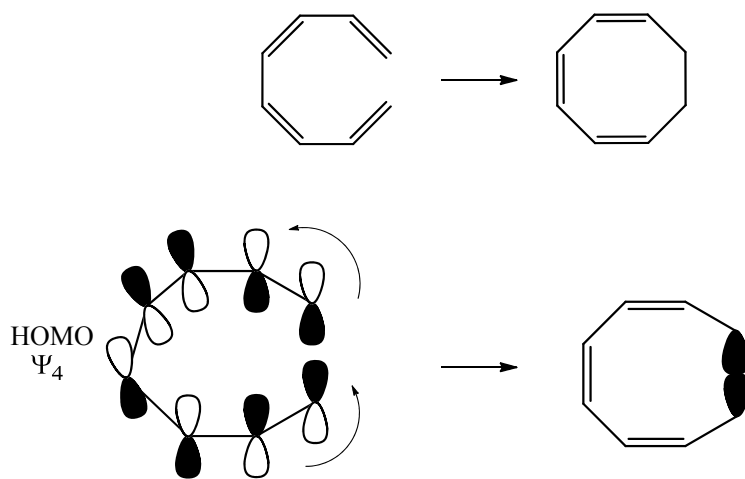

conrotatory closure allows overlap of opposite symmetry orbitals

The HOMO,  $\Psi_4$ , of 1,3,5,7-octatetraene has the p-orbital lobes of opposite symmetry facing in the same direction therefore requiring a “conrotatory” motion for ring closing.